

PRODUCT INDEX

Wholegoods Catalog
Revision 18.1

Solex Corporation

Address:
220 South Jefferson
Dixon CA 95620

PO Box 490
Dixon CA 95620

Phone:
(707) 678-5533

Fax:
(707) 678-9788

Email:
sales@solexcorp.com

Web:
www.solexcorp.com

Note:

All specifications and descriptions in this catalog are subject to change without notice. For detailed pricing information, please call Solex or, for dealers, check our supplemental pricing guide.

Broadcast Spreaders Herd (2-3)	SPREADER
Dump Trailers Pronovost (4 -9)	TRAILER
Dusters Teyme (10)	DUSTER
Gopher Killer Solex (11)	GOPHER
Grass Seeder Kasco (12-14)	GRASS
Handheld Tools Micron Herbi (15) • Zanon (16-17)	HANDHELD
Posthole Diggers, Augers & Post Drivers Pengo (18-27) • Shaver (28-30)	POSTHOLE
Shredders Falc (31-40)	SHREDDER
Snowblowers Pronovost (41-46)	SNOW
Sprayers Demco (see full line catalog) • Enviromist (47-51) • Projet (52-56)	SPRAYER
Tillage and Cultivation Falc Power Harrow (57) • Falc Spader (58-59) • Falc Tillers (60-66) Massano Bed Shaper (67) • Pepin Harrow (68-71) • Robocrop (72)	TILLAGE
Transplanters & Mulch Layers Checchi & Magli (73-79) • Holland (80-81)	TRANSPLANT
Vegetable Seeder Gaspardo (82-84) • Seed Spider (85) • Solex (86) • Stanhay (87-90)	PLANTER
Vineyard-Specific Tools Rinieri (91-96)	VINEYARD

HERD SEEDERS

GT-77 Electric Broadcaster

The GT-77 is designed for use with ATVs and Garden Tractors. It features a galvanized steel hopper, and 12V motor with feed control. A fused wiring harness with quick coupler makes attachment and removal of easy. The GT-77 is equipped with a stainless steel vibrating agitator to coax slow feeding material and a toothed opening plate to control fast feeding materials. Opening gauge easily adjusts material output.



Hopper capacity	77 lbs. (1.4 cu ft)
Dimensions	15.5" (w) x 21" (l) x 25" (h)
Dosage per acre	.5 lbs/500 sq ft to 500 lbs/acre
Feed Opening	Adjustable: thousandths of inch
Opening Control	Low -- in line with seat
Spread plate	Yes — Stainless steel
Hopper agitation	vibrating
Fan	4-bladed lapover aluminium
Hopper build	24 ga. galvanized round
Lid	Lid & Spring Included
Bearings	oillite bronze
Mounting	Garden tractor, ATV, and Cat. 0
Powered by	12V Electric Motor

Part No.	Description	Wt
GT-77-ATV	12 volt electric spin spreader without mount bracket for dry materials, ant and snail baits	48 lbs
672	Blocking kit for ant baits	2 lbs
813	12V/24v rheostat with bracket for ATVs that rpm control is necessary. Spread width: 5 to 28 feet.	1.5 lbs

I-92 & M-12 Broadcasters



Model	I-92	M-12
Powered by	12V motor	PTO
Mount	2" receiver, front/side mount	Cat I Three-pt hitch
Hopper size	3.5 ft ³ ; 184 lbs	3.75 ft ³ ; 192 lbs
Dosage per acre	2 - 500 lbs.	2 - 500 lbs
Opening control	Lower pulley	Lever
Hopper agitation	Rotating agitator	
Fan	4 bladed lap-over aluminum	
Hopper build	24 ga. galvanized steel	
Lid	Lid & Spring	no

Model	Description	Wt.
I-92	I-92 12V Broadcaster	73 lbs
M-12	M-12 PTO Broadcaster	79 lbs
Optional Accessories & Kits		
982	Hopper extension kit: 128 lb. capacity	12 lbs
808A	Width control kit for I-92	4 lbs
822	Front chute kit, complete for I-92	8 lbs
827	Spout kit for I-92	2 lbs
813	Rheostat w/ bracket for I-92; 12/24V	2 lbs
660	2" receiver hitch mount for I-92	13 lbs
544	3 pt hitch kit for I-92	

HERD SEEDERS

550 & 750 Broadcasters

- 3-point Mounted, with shielded telescoping PTO shaft.
- Round Hopper Base prevents lodging of material
- Easy-Adjust Pattern Control for even spreading up to 40 feet wide
- Options include lime agitator, hydraulic or electric controls, hydraulic drive system, skid steer mounting plates, or banding kits for vineyard or nursery spreading



Model	550	750
Hopper size (lbs)	550 lbs	715 lbs
Hopper size (cu ft)	9 cu ft	12 cu ft
Dosage per acre	3 - 1,000 lbs.	
Coverage	Up to 40 acres/hour	
Opening Control	Handle (Remote hydraulic opt.)	
Spread plate	Stainless steel	
Hopper agitation	Removable rotating agitator	
Fan	Aluminum base w/ steel blades	
Hopper base plate	One piece aluminum	
Hopper build	14 ga. steel w/ welded seams	
Bearings	Tapered bearings in gearbox	
Gearbox	oil-bathed step-up; 540/1000 rpm	
Powered by	Quik-Tach shielded PTO shaft	

Model	Description	Wt.
550	Model 550 PTO Broadcaster	222 lbs
750	Model 750 PTO Broadcaster	225 lbs
835	Lid for model 750	24 lbs
1099	Lid adapter kit for small seed hopper	2 lbs
1000	Hyd. control kit (less cyl. & hoses)	31 lbs
158	Lime Agitator	4 lbs
1090	Small seed hopper w/ handle	29 lbs
1028	Small seed hopper controls	13 lbs
217	Cat II pin Kit	10 lbs
248	Hyd motor & valve	22 lbs
629	Skid steer plate	70 lbs

1200 & 2440 Broadcasters



- 3-point Cat II mounted, with shielded telescoping PTO
- Round Hopper Base prevents lodging of material
- Quick Hitch compatible
- Easy-Adjust Pattern Control for spreading to 40' wide
- Options include lime agitator, hydraulic or electric controls, hydraulic drive system, skid steer mounting plates, or banding kits for vineyard or nursery spreading

Model	1200	2400
Hopper size (lbs)	1200 lbs; 20 ft ³	2440 lbs.; 40 ft ³
Dosage per acre	3 - 1,000 lbs.	
Coverage	Up to 40 acres/hour	
Opening Control	Remote hydraulic control	
Spread plate	Yes — Stainless steel	
Hopper agitation	Removable rotating agitator	
Fan	Aluminum base w/ steel blades	
Hopper base plate	One piece aluminum	
Hopper build	14 ga. steel w/ welded seams	
Bearings	Tapered bearings in gearbox	
Mounting	3-Pt Cat. II; also for Quik-Hitch	
Gearbox	oil-bathed step-up; 540/1000 rpm	

Model	Description	Wt.
1200C	Model 1200 Broadcaster	315 lbs
2440	Model 2440 Broadcaster	525 lbs
1087	Lid for model 1200C & 1200B	34 lbs
1136	Lid for model 2440	51 lbs
1099	Lid adapter kit for small seed hopper	2 lbs
1000	Hyd. control kit (less cyl. & hoses)	31 lbs
158	Lime Agitator	4 lbs
1090	Small seed hopper w/ handle	29 lbs
841	Nose cone for 1200C small hopper	5 lbs
1037	Nose cone for 2440 small hopper	10 lbs
1028	Small seed hopper control - 1200	13 lbs
1039	Small seed hopper control - 2440	18 lbs

PRONOVOST DUMP TRAILERS

Off Road Dump Trailers: Puma

TRAILER



PUMA-347AG

51" x 86" (1,295 mm x 2,184 mm) – GVWR 3,000 lbs (1,363 kg)

- 1 double-acting cylinder
- Two-way opening back panel
- Single axle (without tandem, without suspension)
- 2 turf tires (23 x 10.5 x 12) 6 ply
- Swivel hitch
- Rear panel included



PUMA-347AGT

51" x 86" (1,295 mm x 2,184 mm) – GVWR 3,000 lbs (1,363 kg)

- 1 double-acting cylinder
- Two-way opening back panel
- Walking tandem (without suspension)
- 4 tires (18 x 8.5 x 8) 4 ply
- Swivel hitch
- Rear panel included

Complete Specs For All Off-Highway Models Are Listed At End Of Section

Off Road Dump Trailers: 1.5 Ton



P-503

50 1/2" x 69 1/2" (1,283 mm x 1,765 mm) – GVWR 3,000 lbs (1,362 kg)

- Removable panels
- Two-way opening back panel
- Tandem axle
- 4 tires (18.5 x 8.5 x 8) 4 ply
- 1 double-acting cylinder
- Swivel hitch
- Optional manual or electric hydraulic pump



P-505T & P-505M

60" x 94" (1,524 mm x 2,388 mm) – GVWR 5,000 lbs (2,270 kg)

- Removable panels
- Tandem axle
- 4 Turf-Saver 4 ply tires (23 x 10.5 x 12) or 4 Multi Trac 6 ply tires (23 x 10.5 x 12)
- 1 double-acting cylinder
- Swivel hitch
- Optional electric hydraulic pump

Complete Specs For All Off-Highway Models Are Listed At End Of Section

PRONOVOST DUMP TRAILERS

Off Road Service Dump Trailers: 4 Ton



P-508/3S – DUMPS ON 3 SIDES

62" x 99" (1,575 mm x 2,515 mm) – GVWR 8,000 lbs (3,632 kg)

- Removable panels
- Hinged-side panels
- Single axle
- 2 tires (11L15) 8 ply (Tires 11L15FI (D) available)
- 1 single-acting cylinder
- Optional central unloading hatch
- Swivel hitch
- Optional electric hydraulic pump



P-509-60

71" x 105" (1,803 mm x 2,667 mm) – GVWR 8,000 lbs (3,632 kg)

- Removable panels
- Hinged-side panels
- Single axle
- 2 tires (11L15) 8 ply (Tires 11L15FI (D) available)
- 1 double-acting cylinder
- Optional central unloading hatch
- Swivel hitch
- Optional electric hydraulic pump

Complete Specs For All Off-Highway Models Are Listed At End Of Section

Off Road Service Dump Trailers: 4 Ton



P-510/3S – DUMPS ON 3 SIDES

62" x 99" (1,575 mm x 2,515 mm) – GVWR 10,000 lbs (4,540 kg)

- Removable panels
- Hinged-side panels
- Tandem axle
- 4 tires (11L15) 8 ply
- 1 single-acting cylinder
- Optional central unloading hatch
- Swivel hitch
- Optional electric hydraulic pump



P-511-60

71" x 105" (1,803 mm x 2,667 mm) – GVWR 10,000 lbs (4,540 kg)

- Removable panels
- Hinged-side panels
- Tandem axle
- 4 tires (11L15) 8 ply
- 1 double-acting cylinder
- Optional central unloading hatch
- Swivel hitch
- Optional electric hydraulic pump

Complete Specs For All Off-Highway Models Are Listed At End Of Section

PRONOVOST DUMP TRAILERS

Off Road Service Dump Trailers: 8 Tons

TRAILER



P-516

55 3/8" x 117 1/2" (1,413 mm x 2,985 mm) – GVWR 16,000 lbs (7,264 kg)

- Removable panels
- Tandem axle
- 4 tires (11L15) 8 ply (tires 11L15FI (D) and 12.5L15 available)
- 2 double-acting cylinders
- Optional central unloading hatch
- Swivel hitch
- Optional electric hydraulic pump



P-516/3S – DUMPS ON 3 SIDES

90" x 120" (2,286 mm x 3,048 mm) – GVWR 16,000 lbs (7,264 kg)

- Removable panels
- Hinged-side panels
- Tandem axle
- 4 tires (11L15) 8 ply (tires 11L15FI (D) and 12.5L15 available)
- 1 single-acting cylinder
- Optional central unloading hatch
- Swivel hitch
- Optional electric hydraulic pump

Complete Specs For All Off-Highway Models Are Listed At End Of Section

Off Road Dump Trailers: 12 Tons



P-524

84" x 138" (2,134 mm x 3,505 mm) – GVWR 24,000 lbs (10,896 kg)

- Removable panels
- Tandem axle
- 4 tires (12.5 L15) 10 ply
- 1 single-acting cylinder
- Central unloading hatch in standard equipment
- Swivel hitch
- Optional electric hydraulic pump

Accessories for Off-Road Models

ACCESSORIES



PHM-3003
Manual hydraulic pump



P-503-PHEP
Electric hydraulic pump (12V)



PGD
Central unloading hatch available on select models



P-510-PHEP, P-511-PHEP and P-516-PHEP
Electric hydraulic pump (12V)

Complete Specs For All Off-Highway Models Are Listed At End Of Section

PRONOVOST DUMP TRAILERS

Pronovost Off Road Service Trailers (Cont'd)

TRAILER

FEATURES

- Many models dump on 3 sides by positioning the pivots as required
- Removable panels*
- Monocoque girder under the platform
- Reinforced panels*
- Swivel hitch or ball hitch
- Wide range of models
- Precision engineering
- Rear panel automatic opening mechanism*
- Superior workmanship
- Built for intensive use
- Unique design for each model
- Automatic relief valve stopping cylinder action at maximum tilt on P-508, P-510 and P-50710/4E

SPECIFICATIONS – OFF-ROAD SERVICE

MODELS	PUMA-347AG	PUMA-347AGT	P-503	P-505	P-508/3S	P-509-60	P-510/3S	P-511-60	P-516	P-516/3S	P-524
GROSS VEHICLE WEIGHT RATING	1.5 tons	1.5 tons	1.5 tons	2.5 tons	4 tons ¹	4 tons ¹	5 tons	5 tons	8 tons ¹	8 tons ¹	12 tons ²
BOX (interior dimensions)	51" x 86"	51" x 86"	50 1/2" x 69 1/2"	60" x 94"	62" x 99"	71" x 105"	62" x 99"	71" x 105"	55 3/4" x 117 1/2"	90" x 120"	84" x 138"
BED THICKNESS	12G	12G	12G	3/16"	3/16"	3/16"	3/16"	3/16"	3/16"	3/16"	3/16"
SIDE PANEL	12" x 14G	12" x 14G	12" x 12G	14" x 12G	14" x 12G	14" x 12G	14" x 12G	14" x 12G	16" x 12G	16" x 12G	24" x 12G
FRONT/BACK PANEL	12" x 14G	12" x 14G	12 1/4" x 12G	19" x 12G	19" x 12G	19" x 12G	19" x 12G	19" x 12G	24" x 12G	24" x 12G	32" x 12G
REMOVABLE PANEL	1	1	4	4	4	4	4	4	4	4	4
REAR PANEL OPENING	From top or bottom	From top or bottom	From top or bottom	Aut.	Aut.	Aut.	Aut.	Aut.	Aut.	Aut.	Aut.
PLATFORM HEIGHT	24"	24"	22"	29 1/2"	35 1/2"	35 1/2"	35 1/2"	35 1/2"	32"	36 1/2"	39"
OVERALL LENGTH	128"	128"	106"	139"	143"	147"	143"	147"	166"	177"	200 1/2"
OVERALL WIDTH	56"	56"	54"	64"	68"	77"	68"	77"	86"	97"	91"
OVERALL HEIGHT	36"	36"	36"	52 1/2"	60"	60"	60"	60"	62"	65"	72"
FREE HEIGHT/MAX. LIFT	12"	12"	10"	15"	20"	14"	20"	14"	15"	20"	20"
THREAD WIDTH C/C	41"	39 3/4"	36 1/4"	53 1/4"	51"	60"	51"	60"	75 1/2"	75"	72 1/2"
DUMPING ANGLE (back)	47°	47°	47°	47°	47°	47°	47°	47°	47°	47°	47°
DUMPING ANGLE (2 sides)	-	-	-	-	47°	-	47°	-	-	47°	-
GRAIN DOOR	-	-	-	-	Optional	Optional	Optional	Optional	Optional	Optional	Standard
AXLE	Single	Tandem	Tandem	Tandem	Single	Single	Tandem	Tandem	Tandem	Tandem	Tandem
SUSPENSION	Fixe	Agricole	-	-	-	-	-	-	-	-	-
HUBS	5 bolts	4 bolts	4 bolts	5 bolts	6 bolts	6 bolts	6 bolts	6 bolts	6 bolts	6 bolts	8 bolts
HUB CAPACITY	2,500 lbs	1,000 lbs	1,000 lbs	2,500 lbs	5,000 lbs	5,000 lbs	4,000 lbs	4,000 lbs	5,000 lbs	5,000 lbs	5,500 lbs
SPINDLES	2"	1 1/4"	1 1/4"	2"	2 1/4"	2 1/4"	2"	2"	2 1/4"	2 1/4"	2 1/4"
WHEELS	2 on tapered roller bearing	2 on tapered roller bearing	4	4	2	2	4	4	4	4	4
WHEEL DIMENSIONS	12" x 8.5"	8.5" x 8"	8.5" x 8"	12" x 8.5"	15" x 8"	15" x 8"	15" x 8"	15" x 8"	15" x 8"	15" x 8"	15" x 10"
TIRES (standard)	23 x 10.5 x 12 (6 ply) Turf	18 x 8.5 x 8 (4 ply)	12 x 14 x 8"	23 x 10.5 x 12 ³	11L15 (8 ply)	11L15 (8 ply)	11L15 (8 ply)	11L15 (8 ply)	11L15 (8 ply)	11L15 (8 ply)	12.5L15 (10 ply)
• TIRES (optional)	-	-	-	-	11L15FI (D)	11L15FI (D)	-	-	11L15FI (D)	11L15FI (D)	12.5L15FI (F)
• TIRES (optional)	-	-	-	-	-	-	-	-	12.5L15 (10 ply)	12.5L15 (10 ply)	-
HITCH: CLEVIS/SWIVEL	Standard	Standard	Standard	Standard	Standard	Standard	Standard	Standard	Standard	Standard	Standard
HITCH: BALL COUPLER	-	-	-	-	-	-	-	-	-	-	-
JACK	-	-	Standard	Standard	Standard	Standard	Standard	Standard	Standard	Standard	Standard
CYLINDER(S)	1 double acting	1 double acting	1 double acting	1 double acting	1 single acting	1 double acting	1 single acting	1 double acting	2 double acting	1 single acting	1 single acting
APPROXIMATE TOTAL WEIGHT	645 lbs	750 lbs	625 lbs	1,560 lbs	1,840 lbs	1,725 lbs	2,100 lbs	2,000 lbs	2,245 lbs	3,040 lbs	4,195 lbs

¹ Capacity with 11L15FI (D) tires at a speed of 25 MPH.

² Capacity with 12.5L15FI (F) tires at a speed of 25 MPH.

³ For Turf Saver (4 ply) tires, order model P-505T and for Multi Trac (6 ply) tires, order model P-505M.

*Available on select models only.

PRONOVOST DUMP TRAILERS

Highway Service Dump Trailers: 3.5 Tons

TRAILER



P-50710/4E – DUMPS ON 3 SIDES

62" × 99" (1,575 mm × 2,515 mm) – GVWR 7,000 lbs (3,178 kg)

- Removable panels
- Hinged-side panels
- Electric brakes, light system and leaf-spring suspension
- 4 tires (ST 205/75R14) 6 ply
- 1 single-acting cylinder
- Ball coupler 2 5/16" (59 mm), safety chain
- Optional central unloading hatch
- Optional electric hydraulic pump



P-50711/4E

71" × 105" (1,803 mm × 2,667 mm) – GVWR 7,000 lbs (3,178 kg)

- Removable panels
- Hinged-side panels
- Electric brakes, light system and leaf-spring suspension
- 4 tires (ST 205/75R14) 6 ply
- 1 single-acting cylinder
- Ball coupler 2 5/16" (59 mm), safety chain
- Optional central unloading hatch
- Optional electric hydraulic pump

Complete Specs For All Highway Models Are Listed At End Of Section

Highway Dump Trailers: 5 Tons



P-5103S/4E – DUMPS ON 3 SIDES

90" × 120" (2,286 mm × 3,048 mm) – GVWR 10,000 lbs (4,540 kg)

- Removable panels
- Hinged-side panels
- Electric brakes, light system and leaf-spring suspension
- 4 tires (ST 225/75R15) 8 ply
- 1 single-acting cylinder
- Ball coupler 2 5/16" (59 mm), safety chain
- Optional central unloading hatch
- Optional electric hydraulic pump

Highway Trailers Accessories

FEATURES

- Many models dump on 3 sides by positioning the pivots as required
- Removable panels*
- Monocoque girder under the platform
- Reinforced panels*
- Precision engineering
- Superior workmanship
- Built for intensive use
- Unique design for each model



Rear panel automatic opening mechanism available

*Available on select models only.

ACCESSORIES

PHEP

- Electric hydraulic pumps (12V)



P-510-PHEP, P-511-PHEP and P-516-PHEP
Electric hydraulic pump (12V)

Complete Specs For All Highway Models Are Listed At End Of Section

PRONOVOST DUMP TRAILERS

Puma Highway Service Dump Trailers



PUMA-10610

- 72" × 120" (1,828 mm × 3,048 mm) – GVWR 10,000 lbs (4,545 kg)
- Removable back panel
 - 1 3 1/2" single-acting cylinder
 - Leaf-spring suspension
 - 4 tires (ST225/75D15) ply
 - Panels 20" × 14G
 - Electric hydraulic pump (12V) in tool box
 - Handheld switch + 20' lead
 - Electric brakes
 - Battery not included



PUMA-LP12

- 80" × 144" (2,032 mm × 3,657 mm) – GVWR 12,000 lbs (5,454 kg)
- 2 3" single-acting cylinders
 - Slip-spring suspension 12,000 lbs
 - 4 tires (ST235/85R16) ply
 - Panels 18" × 14G
 - Tool box with hasp / hydraulic over electric powerpack (12V)
 - 2 loading ramps, platform mounted
 - Two twin drop axles
 - Battery not included

Specifications: Highway Service Models:

MODELS	P-50710/4E	P-50711/4E	P-5103S/4E	PUMA-10610	PUMA-LP12
GROSS VEHICLE WEIGHT RATING	3.5 tons	3.5 tons	5 tons	5 tons	6 tons
BOX (interior dimensions)	62" × 99"	71" × 105"	90" × 120"	72" × 120"	80" × 144"
BED THICKNESS	3/16"	3/16"	3/16"	12G	10G
SIDE PANEL	14" × 12G	14" × 12G	16" × 12G	20" × 14G	18" × 14G
FRONT / BACK PANEL	19" × 12G	19" × 12G	24" × 12G	20" × 14G	18" × 14G
REMOVABLE PANEL	4	4	4	1	4
REAR PANEL OPENING	Aut.	Aut.	Aut.	From top to bottom	Aut.
PLATFORM HEIGHT	35"	35"	38"	33"	28"
OVERALL LENGTH	143"	147"	177"	161"	201"
OVERALL WIDTH	68"	77"	97"	78"	102"
OVERALL HEIGHT	60"	60"	65"	53 1/2"	46 3/8"
FREE HEIGHT / MAX. LIFT	20"	14"	20"	19"	6"
THREAD WIDTH C / C	52 1/2"	61 1/2"	78"	61"	92 1/2"
DUMPING ANGLE (back)	47°	47°	47°	47°	47°
DUMPING ANGLE (2 sides)	47°	–	47°	–	–
GRAIN DOOR	Optional	Optional	Optional	–	–
AXLE	Tandem	Tandem	Tandem	Tandem	Tandem
SUSPENSION	Leaf-spring	Leaf-spring	Leaf-spring	Leaf-spring	Leaf-spring
HUBS	4	4	4	4	4
HUB CAPACITY	14" × 6"	14" × 6"	15" × 6"	15" × 6"	16" × 6"
TIRES (standard)	ST205/75R14	ST205/75R14	ST225/75R15	ST225/75D15	ST235/85R16
HITCH: CLEVIS / SWIVEL	Option	Option	Option	–	–
HITCH: BALL	Std. 2 3/16"	Std. 2 3/16"	Std. 2 3/16"	Std. 2 3/16"	Std. 2 3/16"
JACK	Standard	Standard	Standard	Standard	Standard
ELECTRIC BRAKES	Standard	Standard	Standard	Standard	Standard
LIGHT SYSTEM (12V)	Standard	Standard	Standard	Standard	Standard
OIL VOLUME REQUIRED	5 L	–	5 L	7.5 L	9.5 L
CYLINDER	1 single acting	1 single acting	1 single acting	2 single acting	2 single acting
BRAKE AWAY KIT	Standard	Standard	Standard	Standard	Standard
BATTERY 12V	Not included	Not included	Not included	Not included	Not included
SAFETY CHAINS	Standard	Standard	Standard	Standard	Standard
APPROXIMATE TOTAL WEIGHT	2,140 lbs	2,040 lbs	3,440 lbs	1,740 lbs	3,500 lbs

TEYME DUSTERS

DTE Three-Point Dusters

DUSTER

- Compact three-point mount steel chassis and fan housing
- Smooth-running oil-bathed gearbox with 1:6 gear ratio
- High volume 11" centrifugal fan
- Rate control system with simple lever control.
- Safety Grill confirms to workplace safety regulations
- Outlets – Each with individual shut-off valve
- Poly hopper with vibrating agitator for smooth delivery
- Large opening with double-vented screw-on lid for easy fillup.



Vibrating Agitator

Hopper	HP	Fan	Air Vol	Dosage	Gearbox	Height	Width	Depth	Wt (lbs)
Conical Poly, 200 lb capacity	10	11" Centrifugal	1312 CFM	lever adjust 0-20 lbs/min	oil-bathed 1:6 ratio	42"	53"	25"	125

DTS Three-Point Dusters



- Steel three-point mount chassis.
- Conical gravity-feed polyethylene hopper with 500 lbs capacity. Hopper has a large opening with double-vented screw-on lid that makes fillups easy.
- A vibrating agitator prevents material from bridging in hopper, ensuring that dust will flow smoothly.
- Dual 15" centrifugal fans deliver 8475 cubic feet per minute of air.
- Lever rate adjustment control that provides 8 different levels of application and allows each side to be independently regulated for dosages from 0 to 0.5 cubic feet per minute.
- Oil-bathed gearbox that has with a 1:7 gear ratio.

Optional 10 outlet row crop boom kit

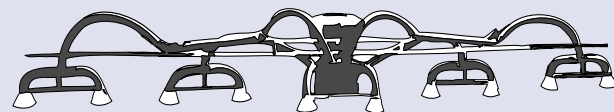

Hopper	Fan	Gearbox	Agitator	Dosage	HP	Adjustment	Wt (lbs)
Conical poly hopper 500 lbs capacity.	Dual 18" Centrifugal	Oil-bathed 1:7 ratio	Vibration	0-180 lbs/acre	16	8 settings. Each side Independently Adjustable	350

SOLEX GOPHER KILLER

GK3 Poison Bait Applicator

Features:

- Adjustable 18" coultter blade mounted on sealed ball bearing hub.
- Adjustable poison seed metering device.
- Large hopper capacity: .65 cu. ft. (Approximately 30 lb. Milo)
- Standard Category I Three Point hitch
- Parking stand is included.
- Filling height is 46-1/2"
- Shear bolt protected shank.
- Dual rear press wheels, 4.80/4.00 x 8 2 ply nylon tire and sealed bearing hubs
- Protective chainguard adheres to safety standards.



Model	Description	Weight
GK3	Solex gopher killer complete with parking stand	255 lbs

Application Method

Poison grain, adjustable in measured amounts, is deposited at regularly spaced intervals 6" to 8" below ground surface. Best application is when ground is moist. Dry, hard ground or extremely wet soil should be avoided. Adjust the top link so that the plow point is slightly downward.

It is most effective to make your application at right angles to the gopher run and with passes 20 to 25 feet apart.

CAUTION should be exercised in handling and storage of poison grain. Any poison grain left exposed on soil surfaces could be consumed by birds or animals. When storing machine, empty hopper and clean machine thoroughly. Poison grain is dangerous to humans and animals. Go slow, not over 5 miles per hour and do a good job.

KASCO SEEDERS

Eco-Drill No-Till Seed Drills



Designed with versatility in mind, the Eco Drill No-Till Drill offers more alternatives than any other single seeder on the market today. Utilizing a unique seed metering system, the Eco Drill is capable of handling a wide variety of seed types including orchard grass, turnip, corn, sorghum and many more.

Features:

- 16" straight coulters slice the ground
- 13" concave openers from a seed-bed trench
- Cast press wheels firm the seedbed to ensure germination
- 3-speed transmission & precise adjustment of the seed metering slots allow a wide range of seed rates
- Excellent for planting pastures, food plots, waterways and mine reclamation.

Part No.	Description	Hitch	Coulters	Row Spacing	No. of Rows	Wt (lbs)
KED-72	No Till Eco-Drill, 6' width	3-point Cat I/II	Notched	8"	9	1385
KED-96	No Till Eco-Drill, 8' width	3-pt Cat I/II	Notched	8"	12	1855

Versa-Drill No-Till Seed Drills

With a smaller frame, the Versa-Drill is the perfect fit for compact tractors and ATVs. This no-till drill features Kasco's patented "Walking Beam Axle," allowing the drill to consistently follow the contour of even the most uneven terrain. As with the Eco-Drill, the Versa-Drill offers a row of slicing blades followed by a row of opening coulters. Our seed placement device guarantees exact seed placement within the 9" rows. Like all Kasco drills and overseeders, the Versa-Drill is ground driven from the heavy cast iron cultipacker wheels in the rear.

The Versa-Drill is available in either a three-point machine of 4-foot or 6-foot width, or in an ATV pull-type machine of 4-foot wide. Optional legume or warm season grass boxes are available for most machines.



Part no	Width	Mount	Row Spacing	# of Rows	Wt (lbs)
KVGT-480	4'	3-pt Cat I	10"	4	650
KVGT-489	4'	3-pt Cat I	9"	5	700
KVGT-728	6'	3-pt Cat I	8"	9	1225
KGVA-480	4'	Pull-Type Electric Lift	10"	4	750
KVGA-489	4'	Pull-Type Electric Lift	9"	5	800



KASCO SEEDERS

Plotter's Choice Food Plot Planter

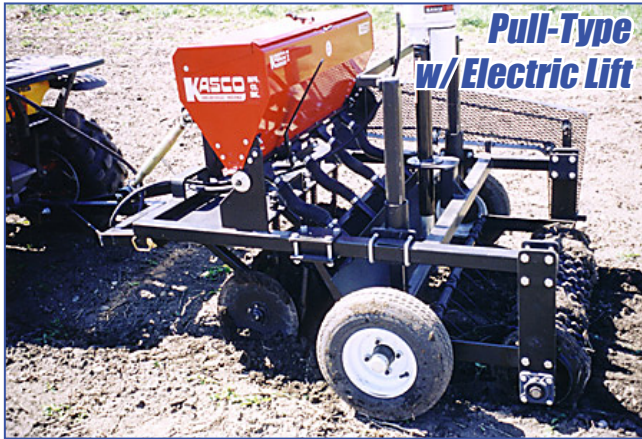

The Plotters Choice is the only machine on the market offering two styles of seeding with one planter: Row-crop drilling for corn or soybeans, and Solid-Stand planting for grasses or anything that requires tighter germination. All of the ground-engaging components are rolling: no shanks to drag trash. It cut through most no-till applications, including corn stalks, bean stubble, or unworked terrain. No need for multiple trips to prep the ground; let the Plotters Choice carry the heavy work for you.

An optional warm season grass seedbox is available, using our patented Positive Feed metering system. Available as an ATV pull-type planter, or with 3-point hitch mount.

Model	Width	Mount	Row Config.	Width	Wt. (lbs)
KPCA-48	4'	Pull-Type with 12V Elect. lift	4 rows 10" centers	4'	704
KPCT-48	4'	3-point	4 rows 10" centers	4'	660
KPCT-72	6'	3-point	8 rows 8" centers	6'	1040

GRASS

Vari Slice Overseeder



Using straight, notched coultter blades on either 3-inch or 4-inch spacing, the Vari-Slice is ideal for yard seeding, waterways, pastures or food plots. Disc blades can be angled to work the ground, or left straight for overseeding. Metering system allows you to plant a wide variety of grass seed sizes. Optional warm season grass box ensures consistent planting of the native grasses. Ground drive provides precise seeding rate. Heavy duty cultipacker wheels follow the drop seed baffle to firm the seedbed and ensure optimal seed-to-soil contact.

- Overseed or broadcast a wide variety of seeds
- 3-inch or 4-inch Blade Spacing
- Native grass and vineyard models
- Precision seed placement and seed-to-soil contact.
- Vary width of seed groove by adjusting the disc angle.

Part No	Description	Hitch	Spacing	Wt
KOS-603	5' Overseeder	3-pt	3"	1140
KOS-604	5' Overseeder	3-pt	4"	1080
KOS-723	6' Overseeder	3-pt	3"	1530
KOS-724	6' Overseeder	3-pt	4"	1480

The Vari-Slice for Native Grasses

KWD-723	6' seeder, 3-spd	3-pt	3"	1530
KWD-724	6' seeder, 3-spd	3-pt	4"	1480
KWD-483	4' seeder, 3-spd	3-pt	3"	1040
KWD-484	4' seeder, 3-spd	3-pt	4"	1010
KWDA-483	4' seeder, 3-spd	pull	3"	1140
KWDA-484	4' seeder, 3-spd	pull	4"	1110



KASCO SEEDERS

Landscape Seed Drills

GRASS



Landscaper's Choice

Kasco's innovative design for the Landscapers Choice provides consistent grass seeding in a prepared seedbed. Utilizing our patented "Walking Beam" axle design, the Landscapers Choice uses two rows of heavy cast iron press wheels. The front row smooths the dirt, preparing it for seed; the back row gives a finished, manicured final grade. Our seed chute uses a baffle system to evenly distribute seed across the entire width of the machine.

The Landscapers Choice is available in either 5-foot or 6-foot widths; they are adaptable to either Cat. 1 or 2 three-point hitch tractors.

Seed-N-Pack

For an economical yet solid primary seeder, the Seed-N-Pack is the right choice. Our ground-driven metering system is consistent – the seed flow stops when the implement stops. There is no waste of expensive seed. Using the same proven metering system as our heavy duty ag drills, The Seed-N-Pack easily adapts to a wide variety of seed sizes and types.

The Seed-n-Pack is available in either a 4-foot or 6-foot wide 3-point machine.

Grade-N-Seed

The Grade-N-Seed decreases labor and increases productivity. With your choice of a landscape rake, overseeder disk blades, or a scarifier, the it will fit any landscaping need.

- Excellent for seeding pastures, food plots or landscaping use
- Available in 4' or 6' widths
- Ideal drop seeder for prepared seedbeds (disked or tilled) seed chute evenly distributes seed across entire width of machine
- Ground driven metering system is consistent and stops seed flow when implement is stopped

Model	Description	Wt (lbs)
Grade-n-Seed		
GSM-1196	Seeder with landscape rake - 6'	1150
GSM-4198	Seeder with disc blades - 6'	1150
GSM-5198	Seeder with 3rd row of "Dirt Worker" teeth	1150
Landscaper's Choice		
KLS-60	5' Seeder with double row of cultipackers	975
KLS-72	6' Seeder with double row of cultipackers	1150
Seed-N-Pack		
KPS-72	Seeder with single row of cultipackers	740

MICRON HERBI HANDHELD SPRAYER

Herbi and Herbiflex Sprayers



HANDHELD

Herbi 4 Sprayer

The Herbi 4 is a hand held spinning disc sprayer for the Controlled Droplet Application (CDA) of herbicides. It can use CDA formulations or traditional water-based products at total spray volumes of only 10-30 litres/hectare. The consistently large spray droplets of around 250 micron minimise any risk of spray drift and fall in a precise 1.2m wide circular spray pattern.

As well as the standard version, the Herbi 4 Xtra model incorporating a handle with on/off liquid flow valve is available. The Herbi 4 Xtra can be attached to 1 or 2.5 litre spray bottles and is ideally suited for smaller spraying jobs.

Herbiflex 4 with Interchangeable Heads

Herbiflex 4 is a versatile and highly economical spinning disc sprayer for the Controlled Droplet Application (CDA) of herbicides. It can apply specific CDA formulations or traditional water-based products at total spray volumes of only 10-30 litres/hectare. The consistently large spray droplets of around 200 microns minimise the risk of spray drift and fall in a precise, adjustable spray pattern.

Herbiflex 4 is available in a choice of spray heads. The A90 head produces an adjustable 10-50cm band width whereas the B120 head is capable of spraying between 15 and 75cm. An optional spray shield is available with the A90 model for spraying sensitive crops.

Features:

- Weighs just 3.3 lbs.
- Battery-powered.
- One pint of herbicide to make a path over one mile long!
- One gallon of total solution covers over one acre.
- Compare that to 20 to 50 gallons you'd waste with conventional sprayers.

	Herbi & Herbiflex	Hydraulic Backpacks
Capacity	5 Pint Tank (Mixed at 20% concentrate*)	4 gallon Tank (Mixed at 1% concentrate*)
Roundup Per Tank	16 oz	5.12 oz
Cost	\$8.32 per tank (16 oz x 52¢)	\$2.66 per tank (5.12 oz x 52¢)
Coverage	1.33 tanks/sprayed acre 5 pint tank; 33,000 sq ft	16.33 tanks/sprayed acre 4 gallon tank; 2,666 sq ft
Cost	\$8.32 for 33,000 sq. ft. \$10.97 to cover 1 acre	\$2.66 for 2,666 sq. ft. \$43.50 to cover 1 acre
Average Roundup Use	25¢ per 1,000 sq ft.	\$1.00 per 1,000 sq. ft

*Based on a Cost of \$66.50 per gallon of roundup. See Roundup label. Fan nozzle flow of .33 GPM 2' spray swath walking at 1.25 mph. Herbi and Herbiflex are registered trademarks of Micron Corporation. Roundup is a trademark of Monsanto Company. All other trademarks and registered trademarks are property of their respective owners.

ZANON HANDHELD TOOLS

ZT40 and ZS50 Electronic Shears



Features:

- Servo operation delivers high cutting speed, power and strength.
- Progressive control allows perfect positioning of the blade throughout cutting cycle.
- Maintenance-free head assembled on bearings for smooth operation and precise, clean cuts promotes healing.
- Ergonomic design for low-fatigue use.
- Titanium-nitride coating cutting edge and steel counter blade provide wear free cutting.



Complete Shear Kit Includes:

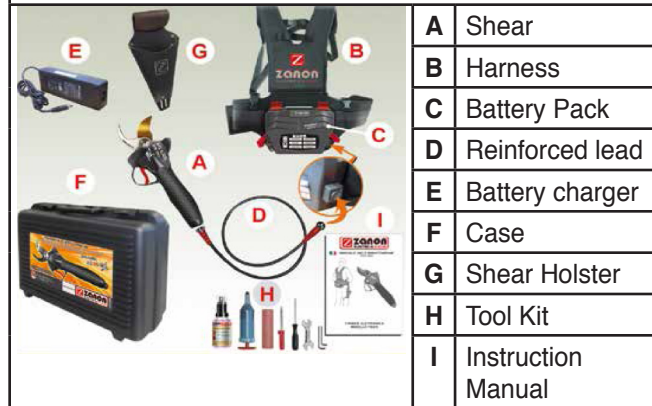

Model	Order Number	Max cut dia	Volt-A/h	Cut time (secs)	Bat. AH	Wt (lbs)
ZT40 No Battery	1.040.085	1.5"		.26	-	1.9
ZT40 600.S Battery	2.060.190	1.5"	50.4	.26	5.8	1.9 5.1
ZS50 No Battery	1.040.422	2"		.26	-	2.2
ZS50 600.S Battery	2.060.245	2"	50.4	.26	5.8	2.2 5.1
600.S Battery Kit	2.060.272	-	50.4	--	5.8	5.07
1300.S Battery Kit	2.060.248	-	50.4		13	
1700.S Battery Kit	2.060.249	-	50.4	-	17	5.5

Model	Order No. ZT40	Order No. ZS50	Pole Length	Wt lbs
Boom Extensions for Zanon Shears				
AS-100	1.030.094	1.040.130	39.3"	2.6
AS-150	1030.095	1.040.131	59"	3
AS-200	1.040.096	1.040.133	78.7"	3.5
AL200	1.040.103	1.040.132	69-100"	5

ZANON HANDHELD TOOLS

ZL600.S Electronic Tying Tool



Features:

- Tying speed of over 60 ties per minute, 5 times faster than manual tying.
- Perfect tying of any tree or branch based on three settings from normal (3 turns) to tight (11 turns)
- Balanced, ergonomic design for comfortable left or right handed all-day use.
- Standard battery and charging system for all day use (13,000 ties).
- Weather-proof.

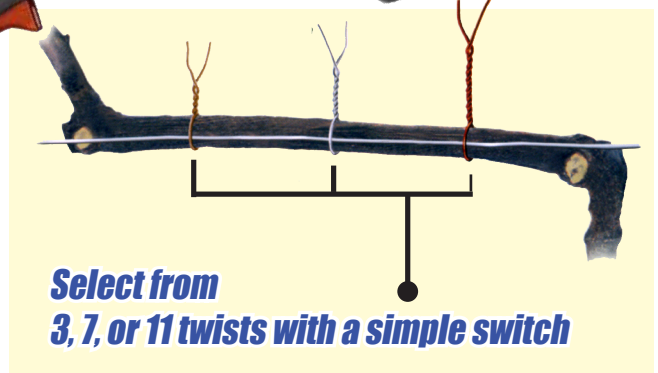

Model	Order No.	mm.	Volt	Tying Time	Bat. AH	Wt. (lbs)
ZL 600.S	1.040.106	30	18V	0.5 sec	3.2	1.5

HANDHELD

Falcon 12V Telescopic Handheld Harvester



Features:

- Ideal for small olive groves.
- Telescopic pole has anti-rotation and quick release system.
- Sturdy frame with gear transmission,
- 500 watt 12v electric motor
- Carbon fiber fingers.
- Available with backpack battery or 40 foot cable for use with any 12V system.

Model	Order No	Description	Pole Length	Wt
AL200F	1040070	Harvester with 40' 12v cable	5.5 to 8'	5.3 lbs
AL300F	1040071	Harvester with 40' 12v cable	7 to 11'	5.7 lbs
AL200F	1040062	Harvester with battery pack	5.5 to 8'	15.8 lbs
AL300F	1040063	Harvester with batter pack	7 to 11'	16.3 lbs

PENGO AUGERS

Ag Aggressor Auger

CONNECTIONS
ROUND **2"**

AUGER DIAMETERS
6 9" 12"

CUT DIAMETER
Cut diameter is 1 1/2" larger than auger diameter.

DRILLING SOIL CONDITIONS:

1	2	3	4	5	6	7
HIGHLY RECOMMENDED	RECOMMENDED	NOT RECOMMENDED				
dirt	sand	silt	clay	gravel	fracturable rock	non-fracturable rock

Pengo's Ag Aggressor® auger is designed for medium duty applications while remaining both cost efficient and safety focused. The 2" round safety hub has all hardware recessed inside the hub to prevent all potential entanglements. Utilizing Pengo's two fluted pilot design, the Ag Aggressor® is a well rounded general purpose auger offering superior efficiency in dry, loose soil.

- **2" Round recessed-safety hub, a Pengo exclusive feature!**
- **3/8" Thick, helicoid flight**
- **Available in 42" or 48" overall length**
- **1/2" Cast alloy steel shank**
- **40°/50° Dual angle teeth with 3-point lock & bolt fasteners**
- **SB-35 S175 pilot bit**



	Item No.	Dia	Teeth	Wt (lbs)	Part No
42" Length	6-LTA-42	6"	2	35	553225
	9-LTA-42	9"	4	52	553226
	12-LTA-42	12"	4	58	553227
48" Length	6-LTA-48	6"	2	45	553228
	9-LTA-48	9"	4	52	553229
	12-LTA-48	12"	4	68	553230

Aggressor Teeth & Pilot Bits

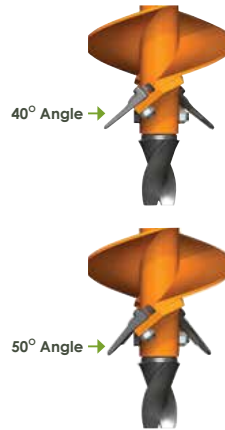

AGGRESSOR® auger teeth are for use in dirt, abrasive soil or fracturable rock, depending on the type of tooth you are using. All types of the 40/50 tooth can be used at either a 40° or 50° angle providing different attack angles based on your drilling condition.

THE NUTS & BOLTS:

for 40/50 Teeth
Carriage Bolt PN 134677
Hex Nut Lock PN 134527



PARTS | Pilot Bits

▲▲▲
SB-35 S175
LBS 3.9
PN 151318



The SB-35 two-fluted pilot is ideal for dry soil conditions.

PARTS | Teeth

▲▲▲
40/50 Tooth
LBS .5
PN 134501



40° Angl

▲▲▲
40/50HFF Tooth
LBS .5
PN 134802



▲▲▲
40/50C Tooth
LBS .65
PN 134519



50° Angl

POSTHOLE

PENGO AUGERS

PTO Aggressor Auger

CONNECTIONS	ROUND 2"
	AUGER DIAMETERS 6" 9" 12" 15" 18" 24"
CUT DIAMETER Cut diameter is 1 1/2" larger than auger diameter.	



DRILLING SOIL CONDITIONS:

HIGHLY RECOMMENDED		RECOMMENDED		NOT RECOMMENDED		
1	2	3	4	5	6	7
dirt	sand	silt	clay	gravel	fracturable rock	non-fracturable rock

Pengo's PTO Aggressor® is designed for professionals and offers superior performance and reliability under high-duty applications. Featuring the Tri-Flow® 350 pilot (an original Pengo® design) the PTO Aggressor® provides longer wear and exceptional performance in a wide variety of soil conditions.



- **Cast Alloy Steel 2" Round Hub**
- **3/16" Thick, Semi-Double Flight**
- **1 piece Cast Head**
- **400/500 Dual Angle Teeth with 3-Point Lock & Bolt Fasteners**
- **TriFlow® 350Pilot Bit with three drill points for longer wear**

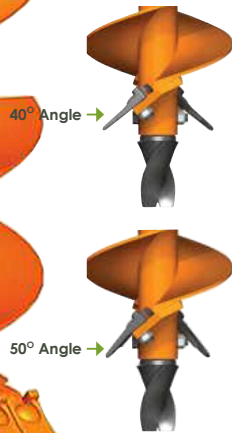

AGGRESSOR® auger teeth are for use in dirt, abrasive soil or fracturable rock, depending on the type of tooth you are using. All types of the 40/50 tooth can be used at either a 40° or 50° angle providing different attack angles based on your drilling condition.

THE NUTS & BOLTS:

for 40/50 Teeth
Carriage Bolt PN 134677
Hex Nut Lock PN 134527

for TriFlow 350 Pilot Bits
3.5" Hex Bolt (6"-9" dia.) PN 174447
4" Hex Bolt (12" plus dia.) PN 174448
Hex Nut Lock PN 134527



Item No.	Dia.	Teeth	30" OAL Part No.	Wt (lbs)	42" OAL Part No.	Wt (lbs)	48" OAL Part No.
9-AR-PTO	9"	4	137141	39	137152	42	137181
12-AR-PTO	12"	4	137142	47	137153	54	137182
15-AR-PTO	15"	5	137143	53	137154	58	137183
18-AR-PTO	18"	6	137144	59	137155	63	137184
24-AR-PTO	24"	8	137145	65	137156	67	137185

PARTS | TriFlow® Pilot Bits

TF-350
LBS | 5
PN | 135088

TF-350HF Pilot
LBS | 5.5
PN | 135089

TF-350C Pilot
LBS | 5.5
PN | 135090

TF-350CXC Pilot
LBS | 5.8
PN | 135091

TF-350HFTC Pilot
LBS | 5.5
PN | 135092

PARTS | Teeth

40/50 Tooth
LBS | .5
PN | 134501

40/50HFF Tooth
LBS | .5
PN | 134802

40/50C Tooth
LBS | .65
PN | 134519

POSTHOLE

PENGO AUGERS

Landscape Aggressor Auger

CONNECTIONS

ROUND 2" 2 9/16"

HEX 2"

SQUARE 2"

AUGER DIAMETERS

6" 9" 12" 15" 18" 24" 30" 36"

CUT DIAMETER

Cut diameter is 1 1/2" larger than auger diameter.

DRILLING SOIL CONDITIONS:

HIGHLY RECOMMENDED

RECOMMENDED

NOT RECOMMENDED

1 dirt

2 sand

3 silt

4 clay

5 gravel

6 hard, stable soil

7 non-homogeneous rock

Pengo's Landscape Aggressor® is the perfect tool for landscaping applications or where smaller prime movers are required. Shorten flight bodies offers substantial weight reduction and performance is enhanced with our double entry flight design. Paired with our TriFlow® 350 pilot, providing three drill points for longer wear, the Landscape Aggressor® provides big performance in a small package.

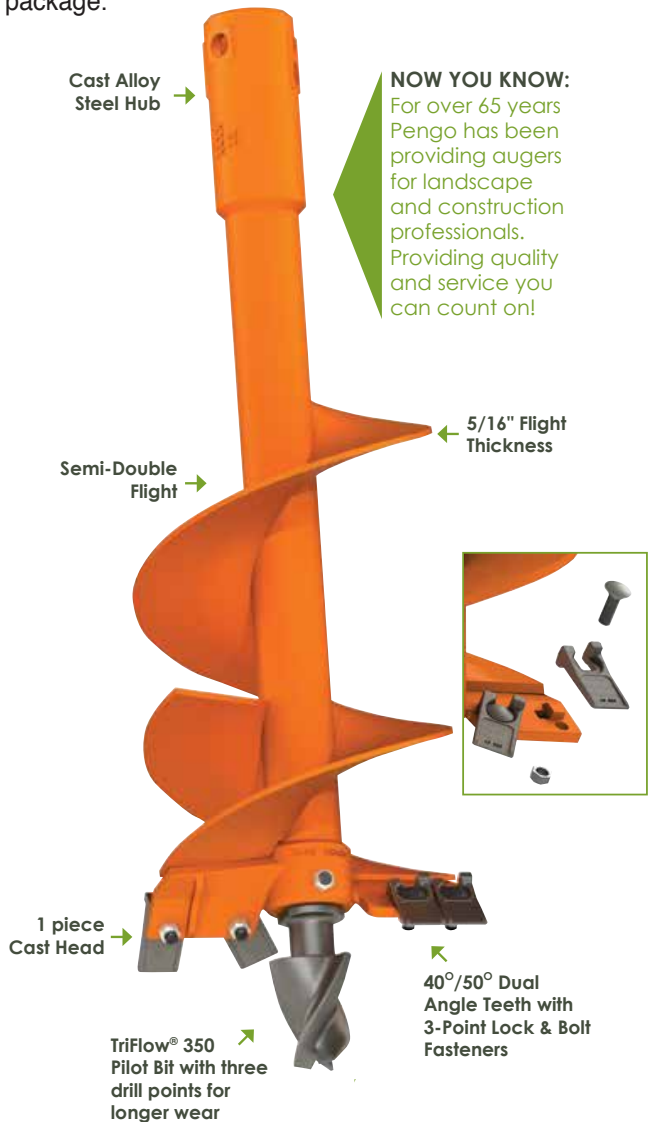

Hub	Model	Dia.	Teeth	Wt (lbs)	Part No
2" square hub	6-MA-42	6"	2	35	137876
	9-MA-42	9"	4	42	137878
	12-MA-42	12"	4	46	137880
	15-MA-42	15"	5	50	137882
	18-MA-42	18"	6	67	137884
	24-MA-42	24"	8	85	137886
2" round	30-MA-42	30"	10	104	137888
	6-MA-42	6"	2	35	138000
	9-MA-42	9"	4	42	138001
	12-MA-42	12"	4	46	138002
	15-MA-42	15"	5	50	138003
	18-MA-42	18"	6	67	138004
2-9/16" round	24-MA-42	24"	8	85	138005
	30-MA-42	30"	10	104	138008
	6-MA-42	6"	2	35	138100
	9-MA-42	9"	4	42	138101
	12-MA-42	12"	4	46	138102
	15-MA-42	15"	5	50	138103
2" hex	18-MA-42	18"	6	67	138104
	24-MA-42	24"	8	85	138105
	30-MA-42	30"	10	104	138106
	36-MA-42	36"	12	125	138109
	6-MA-42	6"	2	35	138080
	9-MA-42	9"	4	42	138082
2-9/16" round carbide	12-MA-42	12"	4	46	138084
	15-MA-42	15"	5	50	138086
	18-MA-42	18"	6	67	138088
	24-MA-42	24"	8	85	138090
	30-MA-42	30"	10	104	138092
	36-MA-42	36"	12	220	138094
48" Overall length	6-MA-48	6"	2	35	138000
	9-MA-48	9"	4	42	138001
	12-MA-48	12"	4	46	138002
	15-MA-48	15"	5	50	138003
	18-MA-48	18"	6	67	138004
	24-MA-48	24"	8	85	138005
48" Overall length	30-MA-48	30"	10	104	138008
	6-MA-48	6"	2	35	138120
	9-MA-48	9"	4	42	138121
	12-MA-48	12"	4	46	138122
	15-MA-48	15"	5	50	138123
	18-MA-48	18"	6	67	138124
48" Overall length	24-MA-48	24"	8	85	138125
	30-MA-48	30"	10	104	138126
	6-MA-48	6"	2	35	102390
	9-MA-48	9"	4	42	102391
	12-MA-48	12"	4	46	102392
	15-MA-48	15"	5	50	138015
30-MA-48	30"	10	104	138016	

POSTHOLE

PENGO AUGERS

Aggressor General Purpose Auger

CONNECTIONS

ROUND 2" 2 5/16"

HEX 2"

AUGER DIAMETERS

6" 9" 12" 15" 18" 24" 30" 36"

CUT DIAMETER
Cut diameter is 1 1/2" larger than auger diameter.



Aggressor® is a professional grade tool designed for constant daily use. The Tri-Flow pilot provides unmatched auger stability and up to 50% longer wear over conventional bits. Double flight provides maximum spoil removal. The 5/16" flight thickness provides long term durability.

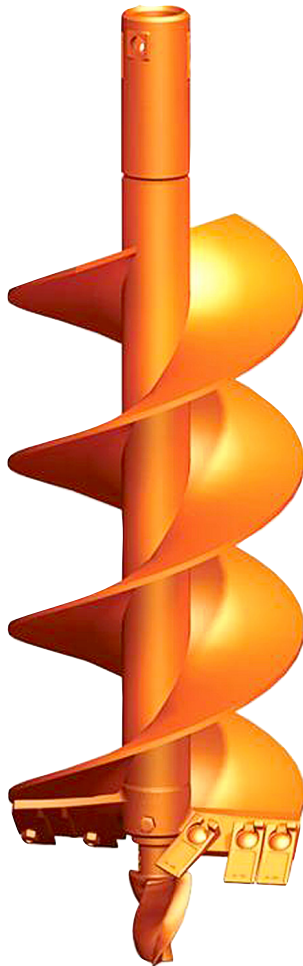

DRILLING SOIL CONDITIONS:

HIGHLY RECOMMENDED		RECOMMENDED		NOT RECOMMENDED		
1	2	3	4	5	6	7
dirt	sand	silt	clay	gravel	fracturable rock	non-fracturable rock

- Cast alloy steel hub
- Double flight: 5/16" thickness
- 1 Piece cast head
- 40°/50° dual angle teeth with 3-point lock & bolt fasteners
- Triflow® 350 pilot bit with three drill points for longer wear

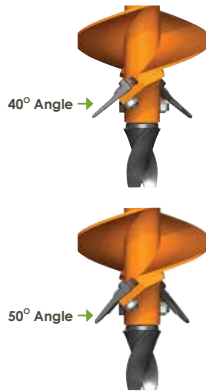

AGGRESSOR® auger teeth are for use in dirt, abrasive soil or fracturable rock, depending on the type of tooth you are using. All types of the 40/50 tooth can be used at either a 40° or 50° angle providing different attack angles based on your drilling condition.

THE NUTS & BOLTS:

for 40/50 Teeth
Carriage Bolt PN 134677
Hex Nut Lock PN 134527

for TriFlow 350 Pilot Bits
3.5" Hex Bolt (6"-9" dia.) PN 174447
4" Hex Bolt (12" plus dia.) PN 174448
Hex Nut Lock PN 134527



	Item	Flight	Dia	Teeth	Wt (lbs)	2-9/16" Round	2" Round	2" Hex
49" OAL	6-AR-49	Semi-Double	6"	2	54	135534	135570	135546
	9-AR-49	Double	9"	4	78	135535	135571	135547
51" OAL	12-AR-51	Double	12"	4	114	135536	135572	135548
	15-AR-51	Double	15"	5	117	135537	135573	135549
	18-AR-51	Double	18"	6	145	135538	135574	135550
	24-AR-51	Double	24"	8	210	135539	135575	135551
	30-AR-51	Double	30"	10	220	135540	135576	135552
	36-AR-51	Double	36"	12	295	135541	135577	135553

PARTS | TriFlow® Pilot Bits

TF-350
LBS | 5
PN | 135088

TF-350HF Pilot
LBS | 5.5
PN | 135089

TF-350C Pilot
LBS | 5.5
PN | 135090

TF-350CXC Pilot
LBS | 5.8
PN | 135091

TF-350HFTC Pilot
LBS | 5.5
PN | 135092

PARTS | Teeth

40/50 Tooth
LBS | .5
PN | 134501

40/50HFF Tooth
LBS | .5
PN | 134802

40/50C Tooth
LBS | .65
PN | 134519

POSTHOLE

PENGO AUGERS

GP Auger Extensions

At times there is a need for a little more depth. Couple your Pengo auger with a Pengo extension to get the job done. We offer a wide variety of extensions from fixed to telescoping with round, square, and hex connections. Whatever your need, contact a Pengo sales team member to determine the best option for your job.



	Model	Hub	Length	Wt (lbs)	Part No.
Telescopic Extensions For CS Augers	G-1.00Rx24 General	1" Round	24"		557091
	G-1.375Hx24 General	1.375" Hex	24"		557092
	LB-1.25Sx24 Little Beaver	1.25" Square	24"		557093
	GH-.875Sx24 Ground Hog	.875" Square	24"		557094
	PC-1.31Rx12 Pengo Collar	2" Pengo Collar	12"		557095
	PC-1.687Rx24 Pengo Collar	2" Pengo Collar	24"		557096
	PC-1.687Rx36 Pengo Collar	2" Pengo Collar	36"		557097
Telescopic Extensions for GP Augers	HE20-12 Standard	H200	12"	22	557142
	HE20-24 Standard	H200	24"	34	557143
	HE20-36 Standard	H200	36"	46	557144
	HE20-48 Standard	H200	48"	58	557145
	HE20-60 Standard	H200	60"	69	557146
	HE20-72 Standard	H200	72"	82	557147
	SA24 x 256 Ext Shaft	R256	24"	22	134668
	Fixed Extensions	RE20-12 Std Fixed	R200	12"	20
RE20-24 Std Fixed		R200	24"	31	557178
RE20-36 Std Fixed		R200	36"	40	557174
RE20-48 Std Fixed		R200	48"	50	557179
RE20-72 Std Fixed		R200	72"	72	557177
RE25-12 Std Fixed		R256	12"	20	134203
RE25-24 Std Fixed		R256	24"	31	134204
RE25-36 Std Fixed		R256	36"	40	134205
RE25-48 Std Fixed		R256	48"	50	134206
RE25-60 Std Fixed		R256	60"	61	134207
RE25-72 Std Fixed		R256	72"	72	134208

PENGO AUGERS

GP Auger Replacement Heads

AGGRESSOR® HEADS

ITEM	DIA	LBS	PN
HEAD AUG [6-AR] CAST	6"	3.4	137692
HEAD AUG [9-AR] CAST	9"	5	137693
HEAD AUG [12-AR] CAST	12"	8	137694
HEAD AUG [15-AR] CAST	15"	9.3	137695
HEAD AUG [18-AR] CAST	18"	10.1	137696
HEAD AUG [24-AR] CAST	24"	12.6	137697



AGGRESSOR

Use the Pengo Aggressor Cast heads to replace or repair your current auger. Simply remove the teeth and pilot and follow the instructions below.

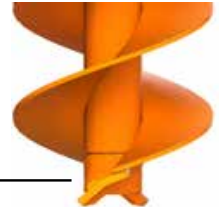

There must be at least 2" of clearance between weld seam and front edge of shank.



STEP 1

Torch off old shanks and pilot adapter, angle torch to remove shanks from bottom side of flight. Leave as much flight as possible.



STEP 2

Grind flight edges. Flight edges should be parallel and in-line with each other.

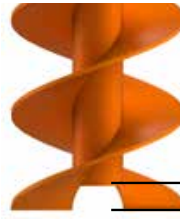

STEP 3

Torch and grind out center shaft flush. End of flight should be approximately 1 3/8" beyond end of center shaft.



STEP 4

Install cast head and weld all around.

Flight Edge Perpendicular to bolt hole

POSTHOLE

TRIMAX® HEADS

ITEM	DIA	NO. TEETH	LBS	PN
TMOBH-6	6"	2	12	135813
TMOBH-8	8"	4	17	135814
TMOBH-9	9"	4	18	135815
TMOBH-10	10"	4	19	135816
TMOBH-12	12"	4	21	135817
TMOBH-14	14"	6	22	135818
TMOBH-16	16"	6	24	135819
TMOBH-18	18"	6	25	135820
TMOBH-20	20"	6	27	135821
TMOBH-24	24"	8	32	135822
TMOBH-30	30"	10	40	135823
TMOBH-36	36"	12	48	135824
TMOBH-42	42"	16	48	135825
TMOBH-48	48"	18	48	135826

For those who want to build their own auger or simply repair an auger, we offer the ever popular TriMax® Weld-On Boring Heads. These heads feature the patented TriFlow® bit and Fas-N-Lok® dirt teeth, 37 Gage on the outside and 5T30 Carbide on the inside.

Once you weld on the TriMax® head to any auger flight of equal diameter you will have the ability to drill in dirt, clay, and light rock.

Each TriMax® Boring Head kit contains the boring head, pilot bit, teeth and hardware.

TRIMAX

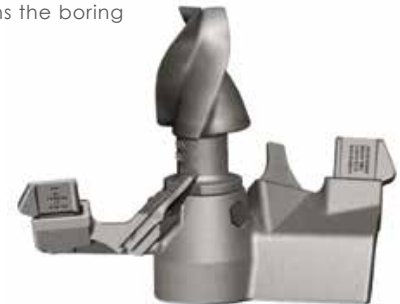

PENGO AUGERS

CS1 Auger Drive

SINGLE SPEED DRIVE UNIT | PN 623010

use Pengo Aggressor® TriMax® Severe Rock Ripper® Augers

REFERENCE SPEED CHART

Flow GPM (Liter)	Theoretical
5	26
10	52
15	78

REFERENCE TORQUE CHART

Pressure (psi)	THEORETICAL Torque (ft/lb)
1200	709
1400	828
1600	946
1800	1064
2000	1183
2200	1301
2400	1419
2600	1538
2800	1656
3000	1774

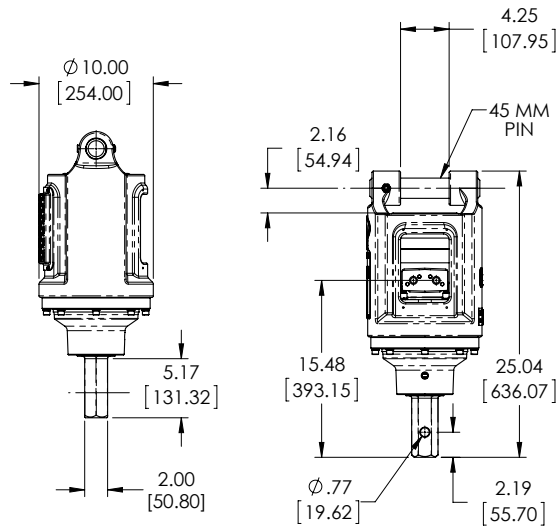

Speed and torque specifications are based on theoretical values and are provided for comparative purposes only.

POSTHOLE

45MM Link Arm

LBS | 7

PN | 623064



45MM Pin

LBS | 1

PN | 620024



Does Not Require a Case Drain

Lightweight and compact



Protective Vents Allow for Hydraulic Motor Cooling

2" Hex Output Shaft

MOUNT for CS-1

This CS-1 Drive and Mount are sold as a unit. Couple your Aggressor®, TriMax® or Severe Rock Ripper® with this unit for a complete General Purpose drive package.



CS-1 Drive and Mount

LBS | 300

PN | 623066

HYDRAULIC MOTOR INFORMATION

Displacement	12.1 cu/in (198cc)
Motor Type	Single Speed Bi-Directional
Motor Output Shaft	1 1/4" Spline 14T
Motor Mount	SAE - A 2 Bolt
Motor Ports	7/8-14 UNF-2B O-Ring
Cross Over Pressure Relief	NA

PLANETARY GEARBOX INFORMATION

Gearbox Type	Planetary Single Stage
Reduction Ratio	3.69:1
Output Shaft	2" Hex
Internal Oil Capacity	25 oz.

GENERAL INFORMATION

Min/Max Flow (gpm)	5/15
Max Pressure (psi)	3000
Max Dia. Auger Bit	24"
Weight	130 lbs.

PENGO AUGERS

CS2 Auger Drive

SINGLE SPEED DRIVE UNIT | PN 623011

use Pengo Aggressor® TriMax® Severe Rock Ripper® Augers

Does Not Require a Case Drain



REFERENCE SPEED CHART	
Flow GPM (Liter)	RPM
10	41
15	61
20	81
25	102

REFERENCE TORQUE CHART	
Pressure (psi)	THEORETICAL Torque (ft/lb)
1200	903
1400	1054
1600	1204
1800	1355
2000	1505
2200	1656
2400	1807
2600	1957
2800	2108
3000	2258

Speed and torque specifications are based on theoretical values and are provided for comparative purposes only.

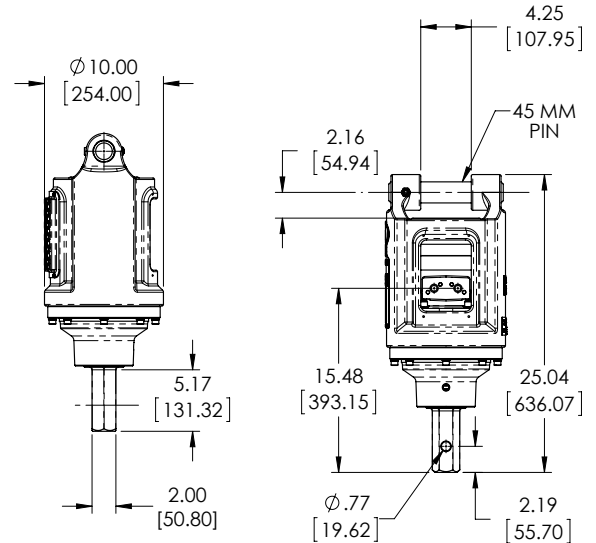

45MM Link Arm

LBS | 7

PN | 623064



45MM Pin

LBS | 1

PN | 620024



HYDRAULIC MOTOR INFORMATION	
Displacement	15.4 cu/in (252cc)
Motor Type	Single Speed Bi-Directional
Motor Output Shaft	1 1/4" Spline 14T
Motor Mount	SAE - A 2 Bolt
Motor Ports	7/8-14 UNF-2B O-Ring
Cross Over Pressure Relief	NA
PLANETARY GEARBOX INFORMATION	
Gearbox Type	Planetary Single Stage
Reduction Ratio	3.69:1
Output Shaft	2" Hex
Internal Oil Capacity	25 oz.
GENERAL INFORMATION	
Min/Max Flow (gpm)	5/25
Max Pressure (psi)	3000
Max Dia. Auger Bit	30"
Weight	130 lbs.

MOUNT for CS-2

This CS-2 Drive and Mount are sold as a unit. Couple your Aggressor®, TriMax® or Severe Rock Ripper® with this unit for a complete General Purpose drive package.

CS-2 Drive and Mount

LBS | 300

PN | 623067



POSTHOLE

PENGO AUGERS

CS3 Auger Drive

SINGLE SPEED DRIVE UNIT | PN 623012

use Pengo Aggressor® TriMax® Severe Rock Ripper® Augers

REFERENCE SPEED CHART	
Flow GPM (Liter)	RPM
15	51
20	68
25	85
30	103

REFERENCE TORQUE CHART	
Pressure (psi)	THEORETICAL Torque (ft/lb)
1200	1075
1400	1254
1600	1434
1800	1613
2000	1792
2200	1971
2400	2151
2600	2330
2800	2509
3000	2689

Speed and torque specifications are based on theoretical values and are provided for comparative purposes only.

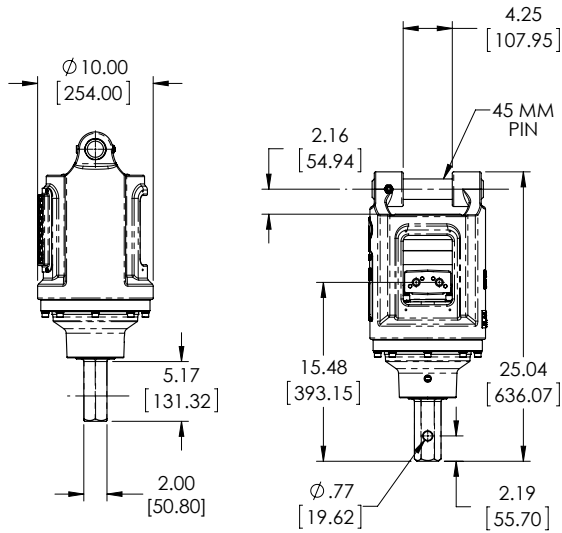

45MM Link Arm

LBS | 7

PN | 623064



45MM Pin

LBS | 1

PN | 620024



MOUNT for CS-3

This CS-3 Drive and Mount are sold as a unit. Couple your Aggressor®, TriMax® or Severe Rock Ripper® with this unit for a complete General Purpose drive package.

CS-3 Drive and Mount

LBS | 300

PN | 623068



Does Not Require a Case Drain

Lightweight and compact



HYDRAULIC MOTOR INFORMATION

Displacement	18.3 cu/in (300cc)
Motor Type	Single Speed Bi-Directional
Motor Output Shaft	1 1/4" Spline 14T
Motor Mount	SAE - A 2 Bolt
Motor Ports	7/8-14 UNF-2B O-Ring

PLANETARY GEARBOX INFORMATION

Gearbox Type	Planetary Single Stage
Reduction Ratio	3.69:1
Output Shaft	2" Hex
Internal Oil Capacity	25 oz.

GENERAL INFORMATION

Min/Max Flow (gpm)	5/30
Max Pressure (psi)	3000
Max Dia. Auger Bit	36"
Weight	130 lbs.

PENGO AUGERS

CS4 Auger Drive

SINGLE SPEED DRIVE UNIT | PN 623018

use Pengo Aggressor® TriMax® Severe Rock Ripper® Augers

Does Not Require a Case Drain



Lightweight and compact

Protective Vents Allow for Hydraulic Motor Cooling

2" Hex Output Shaft

REFERENCE SPEED CHART	
Flow GPM (Liter)	RPM
20	52
25	65
30	78
35	91

REFERENCE TORQUE CHART	
Pressure (psi)	THEORETICAL Torque (ft/lb)
1200	1416
1400	1652
1600	1888
1800	2124
2000	2360
2200	2596
2400	2832
2600	3068
2800	3304
3000	3540

Speed and torque specifications are based on theoretical values and are provided for comparative purposes only.

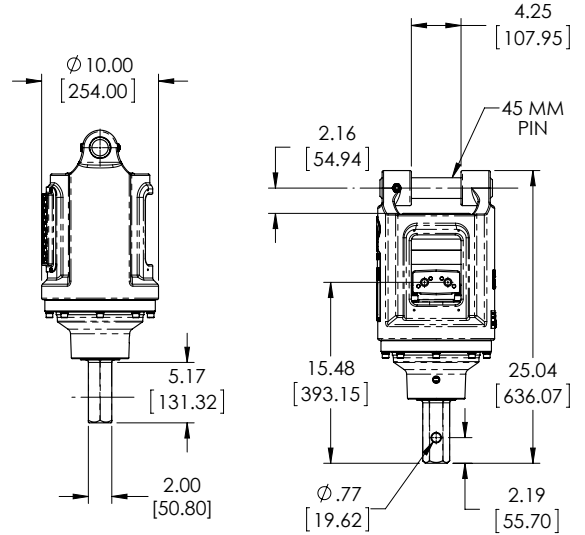

45MM Link Arm

LBS | 7

PN | 623064



45MM Pin

LBS | 1

PN | 620024



HYDRAULIC MOTOR INFORMATION

Displacement	24.1 cu/in (395cc)
Motor Type	Single Speed Bi-Directional
Motor Output Shaft	1 1/4" Spline 14T
Motor Mount	SAE - A 2 Bolt
Motor Ports	7/8-14 UNF-2B O-Ring
Cross Over Pressure Relief	NA

PLANETARY GEARBOX INFORMATION

Gearbox Type	Planetary Single Stage
Reduction Ratio	3.69:1
Output Shaft	2" Hex
Internal Oil Capacity	25 oz.

GENERAL INFORMATION

Min/Max Flow (gpm)	5/35
Max Pressure (psi)	3000
Max Dia. Auger Bit	36"
Weight	130 lbs.

MOUNT for CS-4

This CS-4 Drive and Mount are sold as a unit. Couple your Aggressor®, TriMax® or Severe Rock Ripper® with this unit for a complete General Purpose drive package.

CS-4 Drive and Mount

LBS | 300

PN | 623069



POSTHOLE

SHAYER POST HOLE DIGGERS

PTO Post Hole Diggers



Post hole diggers for even the toughest conditions: Shaver's lineup of PTO-powered post hole diggers are engineered for even the toughest conditions. With four models to choose from, there's a PTO-powered post hole digger to meet your needs.

Standard Auger Options: Shaver offers a wide variety of augers, including diameters from 4 to 30 inches. Our augers come in a standard length of 42 inches and are available in semi-double flight and double flight. Bolt-on auger extensions at 9 and 14 inches are available when added depth is needed.

Orchard Augers: Shaver orchard augers come in standard diameters of 16, 18, 24 and 30 inches with a standard length of 30 inches. The points on these augers are extremely hard austempered ductile iron for longer wear. Cutting teeth are forged steel and are bolted on for easy replacement.

Rock Augers: Designed for extremely rugged conditions, Shaver rock augers are available in diameters ranging from 4 1/2 to 30 inches. These augers feature replaceable carbide bullet teeth, a 3/4-inch-thick double-flight boring head and 3/8-inch-thick flighting with Rockwell 65 hardfacing.

Down Pressure Kit: Shaver's Down Pressure Kit gives you heavier-duty power by supplying 500 lbs. of downward force on the unit. The unit is powered using the hydraulics from tractor, so it doesn't interfere with the regular operation of the digger. Ideal for compacted soil, rocky areas or semi-frozen ground.

Power:

Select from four powerful PTO-driven models of Shaver post hole diggers.

Durability:

Each unit features an enclosed gearbox to ensure longer life. Plus, each of the four models features a fully enclosed PTO shaft shield at both output and input points of the gearbox to provide safety and protection from dirt and moisture.

Strength:

Straddle-mounted, tapered roller bearings for strength.

POSTHOLE

Model	Model 101	Model 301H	Model 601H	Model 901
Arch (Yoke)	1/2"-thick steel to Cat. 0 & I, 3-pt. hitch	3" OD tubing with reversible steel pins to fit Cat. I & II, 3-pt. hitch		
Boom	Standard	Standard	Standard	Standard
Bearings	Deep groove ball bearing w/ needle bearing	Tapered roller, straddle mounted, one each side of gear with needle bearing for rigidity, strength, compact design		
Input Shaft	1 1/4" diameter	1 1/4" diameter	1 1/4" diameter	1 3/8" diameter
Shear Pin	1/4", grade 2 on input shaft with roll pin to hold PTO shaft	3/8", grade 2 on input shaft with roll pin to hold PTO shaft	3/8", grade 2 on input shaft with roll pin to hold PTO shaft	Two 1/2" grade 2 bolts on output shaft
Standard Auger Diameters	4", 6" and 9" semi-double + 4" double flight	4", 6", 9", 12" and 14" semi-double or double flight	4", 6", 9", 12" and 14" semi-double or double flight and 16", 18" and 24" double flight	4", 6", 9", 12" and 14" semi-double or double flight and 16", 18", 24" and 30" double flight
Orchard Augers	N/A	N/A	16", 18", 24" double flight	16", 18", 24", 30" double flight
Cutting Teeth	Bolted on, forged steel, replaceable on 6" and 9" augers	Bolt on, forged steel, replaceable on 6", 9", 12" and 14" augers	Bolted on, forged steel, replaceable on 6-24" augers	Bolted on, forged steel, replaceable on 6-30" augers
Down Pressure Kit	500 lbs. additional pressure, 2"-diameter cylinder, 8" stroke, 2-way valve for use with boom/3-pt. mount			

SHAYER POST HOLE DIGGERS

Hydraulic Post Hole Diggers

Skid Steer Mount

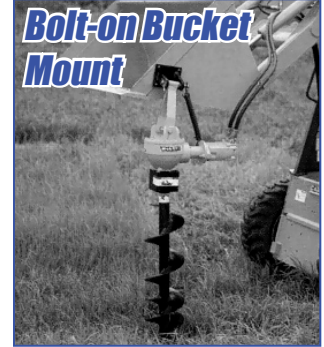

Shaver's lineup of hydraulically powered diggers includes two models. The Model 510 gives you 700 foot-pounds of torque and requires 5-10 gpm. The Model 1020 offers 1,000 foot-pounds of torque with a hydraulic requirement of 10-20 gpm.

Standard Auger Options: Shaver offers a wide variety of augers, including diameters from 4 to 30 inches. Our augers come in a standard length of 42 inches and are available in semi-double flight and double flight. Bolt-on auger extensions at 9 and 14 inches are available when added depth is needed.

Orchard Augers: Shaver orchard augers come in standard diameters of 16, 18, 24 and 30 inches with a standard length of 30 inches. The points on these augers are extremely hard austempered ductile iron for longer wear. Cutting teeth are forged steel and are bolted on for easy replacement.

Rock Augers: Designed for extremely rugged conditions, Shaver rock augers are available in diameters ranging from 4 1/2 to 30 inches. These augers feature replaceable carbide bullet teeth, a 3/4-inch-thick double-flight boring head and 3/8-inch-thick flighting with Rockwell 65 hardfacing.

Down Pressure Kit:

Shaver's Down Pressure Kit gives you heavier-duty power by supplying 500 lbs. of downward force on the unit. The unit is powered using the hydraulics from tractor, so it doesn't interfere with the regular operation of the digger. Ideal for compacted soil, rocky areas or semi-frozen ground.

Model	Model 510	Model 1020
Bolt-On Bucket Mount	Optional	
Boom/3-pt Mount	Optional	
Skid Loader Fast-Tach	Optional	
Gearbox	3.18:1 ratio	
Bearings	Tapered roller, straddle mounted, one each side of each gear for rigidity, strength, compact design	
Seals	Completely enclosed dual lip, high-quality spring loaded	
Input Shaft	1 1/4" diameter	
Output Shaft	2" solid	
Hydraulic Motor	5-10 gpm, 1500-3000 PSI, 1 1/4" output shaft, max. torque 700 ft. lbs.	10-20 gpm, 1500-3000 PSI, 1 1/4" output shaft, max. torque 1000 ft lbs.
Standard Augers	42" length; 4", 6", 9", 12" and 14" semi-double flight or double flight	42" length; 4", 6", 9", 12" and 14" semi-double flight or double flight; 16", 18" and 24" double flight
Auger Extensions	9" and 14"	
Orchard Augers	N/A	16", 18", 24" double flight
Auger Point	Austempered ductile iron replaceable on 6", 9" and 12" augers	Austempered ductile iron replaceable on 6-24" augers
Cutting Teeth	Bolted on, forged steel replaceable on 6", 9" and 12" augers	Bolted on, forged steel replaceable on 6-24" augers
Shipping Weight	113 lbs.	115 lbs.
Down Pressure Kit	500 lbs. additional pressure, 2"-diameter cylinder, 8" stroke, 2-way valve for use with boom/3-pt. mount	

POSTHOLE

SHAYER POST DRIVERS

HD Series Hydraulic Post Drivers

Fast, powerful, and reliable Shaver post drivers are the world's finest. Built far heavier than the job requires, with only six moving parts, they work year after year without breakdown. And Shaver post drivers can be mounted on tractors or skid-steer loaders.

We developed the first powered driver over 50 years ago. Today, we make high quality post drivers for farmers and professionals worldwide. As thousand of satisfied users can attest: With Shaver, you buy with confidence.

Features:

- Fast driving - up to 40 strokes/minute drive a 4-5" post in 10-15 seconds.
- Powerful- Drives steel, wood, or even a railroad tie
- Easy driving - Drives posts straight and true on almost any terrain. It will not split or "mushroom" top of posts.
- No digging, no pointing, no tamping, and no setting.



Model Shown: Shaver Model HD-12H

POSTHOLE

Model	HD-8	HD-10	HD-12
Impact	30,000 lbs	71,500 lbs	100,000 lbs
Effective spring hammer weight	360 lbs	725 lbs	1,100 lbs
Operating ht.	53"-126"	53"-128"	53"-128"
Max post dia.	7-1/8"	8-3/4"	10-7/8"
Max post length	10'	10'	10'
No. of block studs	4	4	6
No. of nyrim blocks	4	4	6
With manual base plate	15° fore/aft 15° side/side		N/A
With hydraulic base plate	15° fore/aft 15° side/side		20° fore/aft 25° side/side
Pilot auger attachment	N/A	Optional	Optional
3-pt hitch	Cat. I & II	Cat II & III	
Mounting options	Front, rear or skid loader		Rear or skid loader
Hydraulic Requirement	3-4 GPM 1500 PSI	12 GPM 1500 PSI	15 GPM 2000 PSI
Weight with hyd. base plate	486 lbs.	714 lbs.	957 lbs.
With manual base plate	438 lbs.	694 lbs.	N/A
Positioners	SB-02	SB-12	SB-22
Width	66" - 90"	66" - 90"	92" - 116"
Height	37.5"-55.5"	37.5"	37.5"
Weight	705 lbs	680 lbs	861 lbs
Swivel	0-155°		

Part No.	Description
HD-8 Driver	
HD-8	Post driver with manual base plate
HD-8H	Post driver with hydraulic base plate
HD-8FMPC	Front mounting package complete
HD-8RMPC	Rear mounting package complete
HD-8SSMPC-S	Skid steer mount - steel tank
HD-8SSMPC-P	Skid steer mount - plastic tank
MB-01-A	3-Pt. Mount (less hardware)
SB-25	Super slide assembly
HD-8HCK	Hydraulic conversion kit
CB-1	Concrete breaker
HD-10 Driver	
HD-10H	Post driver with hydraulic base plate
HD-10SSMPC-S	Skid steer mount - steel tank
HD-10SSMPC-P	Skid steer mount - plastic tank
HD-10FMPC	Front mount
HD-10RMPC-II	Rear mount- category II
HD-10RMPC-III	Rear mount - category III
MB-1201A	3 Point mount (less hardware)
SB-26	Positioner assembly
SB-16	Mini positioner
SB-06	Mini positioner (expandable)
HD12 Driver	
HD-12H	Post driver with hydraulic base plate
HD12-SSMPC-S	Skid steer mounting - steel tank
HD12-SSMPC-P	Skid steer mounting - plastic tank
HD12-RMPC-II	Rear mounting - Category II
HD12-RMPC-III	Rear mounting - Category III
MB-1201A	3 Point mount (less hardware)

FALC SHREDDERS

Cat Shredder

Cat F

Fixed Hitch Model

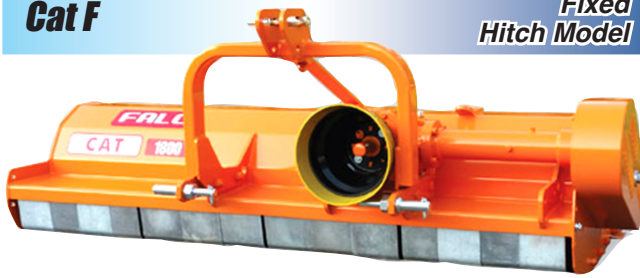

Cat SP

Hydraulic Offset Model

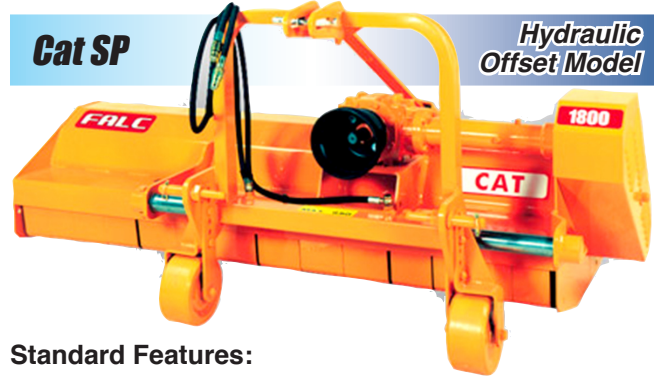

Rotor and Drive Pulleys

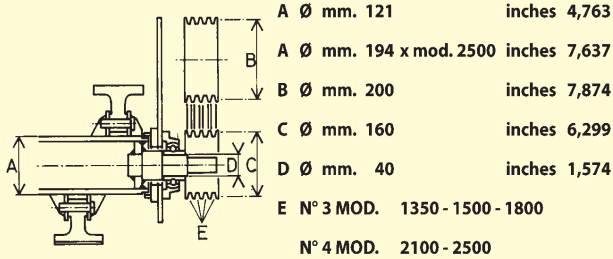

Standard Features:

- “F” series has one position manual offset. “SP” offsets hydraulically
- 5.5” rear roller for level cutting and height adjustment.
- 20-60 HP required.
- Electronically balanced rotor and long-life rotor bearings for smooth operation Rotor diameter is 4.7”
- Hardened steel hammers are standard. Type 1 blades are also available.
- Harvest tines and front wheels are available as optional equipment.

Dimensions:

Model	A	B	C	D
Cat F				
1200F	23.9"	24.9"	23.9"	24.9"
1350F	15.4"	39.4"	29.1"	25.7"
1500F	15.4"	45.0"	29.1"	31.3"
1800F	15.4"	56.2"	29.1"	42.4"
2100F	15.4"	67.4"	29.1"	53.6"
2500F	36.1"	63.4"	50.2"	49.3"
Cat SP				
1350SP	23"	32"	shift 8" from center	
1500SP	23"	38"	shift 8" from center	
1800SP	23"	49"	shift 8" from center	
2100SP	23"	60"	shift 8" from center	
2500SP	36"	64"	shift 8" from center	

Blade Options

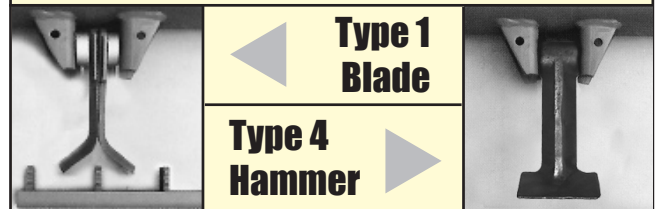

Model No.	Width	Tractor HP	Weight (lbs)	No. of Blades Type 1	No. of Hammers
800F*	32"	20-60	573	20	10
1000F*	40"	20-60	616	27	14
1200F*	47"	20-60	653	32	16
1350F	53"	20-60	689	36	18
1500F	59"	30-60	739	40	20
1800F	71"	40-60	829	48	24
2100F	83"	50-60	924	56	28
2500F*	98"	50-60	1124	68	34
1350SP	53"	20-60	777	36	18
1500SP	59"	30-60	823	40	20
1800SP	71"	40-60	917	48	24
2100SP	83"	50-60	1012	56	28
2500SP	100"	50-60	1210	68	34

*on request

FALC SHREDDERS

Condor Shredder

Condor SP

Hydraulic Offset



Condor F

2 Position Hitch



Standard Equipment:

- Rear roller
- Gearbox with internal freewheel.
- Shredder Bar
- Rear hood and bar for harvest tines.
- 540 rpm PTO shaft
- F model has 2 position hitch, while SP model has hydraulic offset.

Rotor and Drive

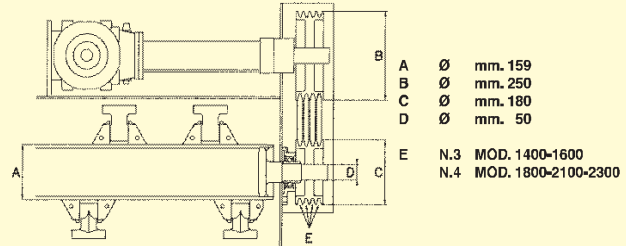

SHREDDER

Model	A	B	A/1	B/1
F 1600	15"	48"	30"	33"
F 1800	15"	55"	30"	40"
F 2300	32"	58"	45"	45"
SP 1400	14"	41"	31"	24"
SP 1600	14"	48"	31"	31"
SP 1800	14"	56"	31"	38"
SP 2100	14"	70"	31"	52"
SP 2300	20"	70"	38"	53"

Model	Description	HP	Wt (lbs.)	No of Hammers
Condor 1400F	43" Shredder 2 position hitch	50-70	961	16
Condor 1600F	62" Shredder; 2 position hitch	50-70	1012	16
Condor 1800F	70" Shredder; 2 position hitch	50-70	1078	18
Condor 2300F	90" Shredder; 2 position hitch	50-70	1276	24
Condor 1400SP	55" Shredder; 2 position hitch	50-70	1089	14
Condor 1600SP	62" Shredder; hyd. offset hitch	50-70	1133	16
Condor 1800SP	70" Shredder; hyd. offset hitch	50-70	1199	18
Condor 2100SP	84" Shredder; hyd. offset hitch	50-70	1320	22
Condor 2300SP	90" Shredder; hyd. offset hitch	60-70	1398	24

Options

- Pair of Front Wheels -F
- Pair of Front Wheels - SP
- Pair of Skids

Rear Tines:

1400	9 rear tines for model 1400
1600	10 rear tines for model 1600
1800	11 rear tines for model 1800
2100	13 rear tines for model 2150
2300	15 rear tines for model 2300

FALC SHREDDERS

Super Sax Shredder



Reversible Hitch

For fast, easy front or rear tractor mounting.



Standard Equipment:

- Front and rear hitch and PTO allow for both front and rear tractor mounting.
- Hydraulic offset hitch is standard equipment.
- 540 rpm PTO shaft
- 4 groove pulley for 1600 & 1800
- 5 groove pulley for 2100
- Rear roller & 2 front support wheels are standard.

Blade Options

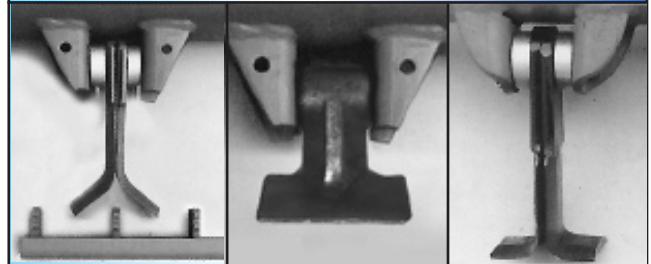

**Type 1
Blade**

**Type 4
Hammer**

**Type 5
Blade**



Super Sax Drive Pulleys and Rotor

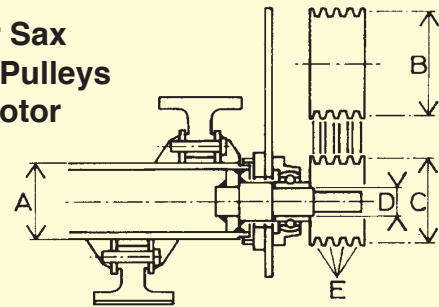

- A) Ø mm. 193,7 inches 7,626
- B) Ø mm. 225 inches 8,858
- C) Ø mm. 180 inches 7,087
- D) Ø mm. 60 inches 2,362
- E) N° 5 MOD. 2100
N° 4 MOD. 1800 - 1600

Model	1600	1800	2100
Figure A	29"	39"	48"
Figure B	34"	34"	34"
Figure C	53"	63"	72"
Figure D	10"	10"	10"

Model No.	Width	HP	No. of Blades	No. of Hammers	Wt (lbs)
SAX 1500	58"	50-100	24	12	1654
SAX 1600	63"	50-100	24	12	1672
SAX 1800	72"	55-100	28	14	1782
SAX 2100	82"	60-100	32	16	1892
Optional Equipment					
40214120	Harvest Tines (all models)				
	Front Wheel pair (all models)				

FALC SHREDDERS

Zenit Shredder

The Falc Zenit Shredder is a low-profile shredder designed for orchards, vineyards, and row crop.

Zenit F

Fixed Hitch



Zenit SP

Hydraulic Offset



Standard Equipment:

- 540 RPM PTO Shaft
- Hood and replaceable liner
- Heavy duty hammers & shredder bar (blades optional)
- Internal free wheel - all models
- Bar for harvest tines (Tines Optional)
- Rear roller assembly



Rear Door

Rear door and roller are standard. Harvest tines optional.

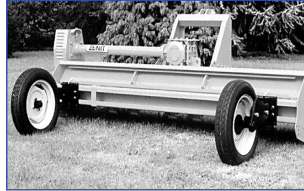

Gauge Wheels

Gauge wheels are available as optional equipment.

Rotor and Drive Specifications

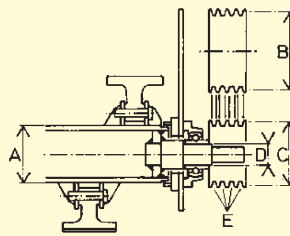

- A) Ø inches 7.63
- B) Ø inches 9.84
(1400-1600-1800-2100-2300)
- B) Ø inches 8.86
(2500-2700-3000)
- C) Ø inches 7.09
(1400-1600-1800-2100-2300)
- C) Ø inches 7.87
(2500-2700-3000)
- D) Ø inches 1.97
- E) N° 3 MOD. 1400
- E) N° 4 MOD. 1600-1800-2100-2300
- E) N° 5 MOD. 2500-2700-3000

SHREDDER

Model SP Hitch Offset

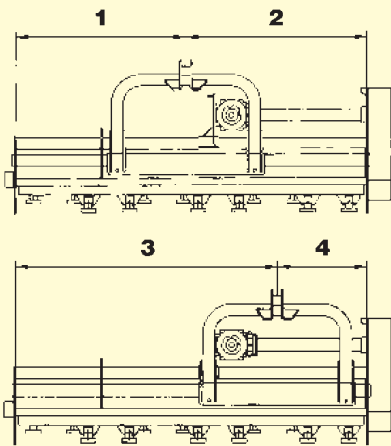

	Centered		Full Offset	
	1	2	3	4
1600	28.9"	33.5"	52.4"	9.9"
1800	35.9"	33.5"	59.6"	9.9"
2100	33.5"	73.75"	9.9"	
2300	49.5"	41.2"	73.2"	18"
2500	51.1"	46.75"	74.75"	31.1"
2700	53.9"	51"	77.5"	27.4"
3000	62.5"	56.6"	86"	33"

Model No.	Shred Width	Total Width	No. of Blades	No. of Hammers	Wt (lbs)
1600F	63"	73"	32	16	1312
1800F	71"	81"	36	18	1389.
2100F	83"	93"	44	22	1587
2300F	91"	101"	48	24	1764
2500F	98"	108"	52	26	1918
2700F	106"	116"	56	28	2094
3000F	118"	128"	64	32	2249
1600SP	63"	73"	32	16	1455
1800SP	71"	81"	36	18	1587
2100SP	83"	93"	44	22	1764
2300SP	91"	101"	48	24	1874
2500SP	98"	108"	52	26	2006
2700SP	106"	116"	56	28	2183
3000SP	118"	128"	64	32	2403

Optional Equipment

- Skids
- Front Wheels "F"
- Front Wheels "SP"
- 2nd shredder bar installed
- Harvest Tines
- Rear Wheels

FALC SHREDDERS

Top Orchard Shredder

The Falc Top Shredder is an extremely strong, heavily built machine for the shredding of orchard prunings such as almond and walnuts.

Built specifically to help growers comply to burn restrictions, the Top provides an economical way to clear heavy prunings

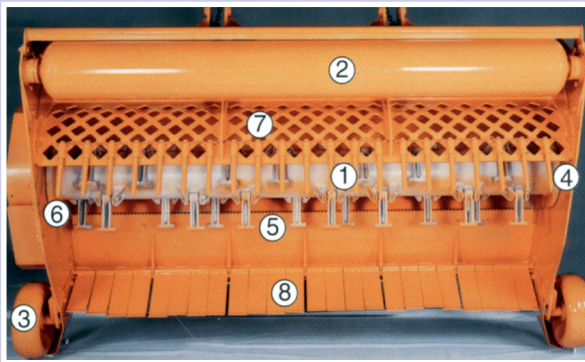

1. Electronically balanced rotor.
2. Rear roller is height adjustable.
3. Front support wheels are height-adjustable and in conjunction with the adjustable rear roller, provide a steady cutting height.
4. Roller bearings provide smooth operation.
5. Falc no. 3 durafaced hammers quickly break down prunings up to 3" in diameter.
6. Standard harvest tines.
7. Rear grill ensures fine, uniform choppings.
8. Wide, tall entrance accepts larger prunings.

- Extra heavy duty construction to deal with the special demands of heavy orchard prunings.
- Reduces branches up to 3" in diameter to fine cuttings
- 2110 rpm rotor propels Falc's heavy durafaced hammers to 250 feet per second at tips.
- Automatic belt tensioning system
- Front or Rear Mount
- Rear Roller and front support standard.

Rotor and Drive Specifications

- A:** 9.6" diameter x .4" wall thickness
- B:** 12" Diameter
- C:** 8.3" Diameter
- D:** 7.8" Diameter
- E:** No of belts:
2500 - 2700: 5
3200: 6

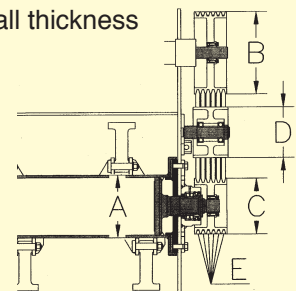

Model	Tractor HP	Wt (lbs)	Hammers	PTO RPM	Work Width	Total Width
2700	90-160	3968	28	1000	105"	114"
3200	90-160	4453	34	1000	126"	135"

FALC SHREDDERS

Vison & Vison California Shredders

The extra heavy duty FALC Vison has the highest rotor speed in the industry to insure excellent cutting quality. Orchard, vineyard, and row crop models available.



Standard Equipment:

- 1000 rpm pto standard; 540 rpm available
- Requires 70-160 HP
- Automatic belt tensioner on six groove pulleys
- Internal free wheel gearbox
- Type I blades standard
- Quick hitch compatible
- Closed Hood
- Replaceable steel wear sheet.

Model No.	Width	HP	No. of Blades	No. of Hammers	Wt (lbs)
Vison Shredder					
Vison 2700	105"	70-160	56	28	2637
Vison 3200	125"	70-160	68	34	2901
Vison 3600	144"	70-160	80	40	3175
Vison 4000	158"	70-160	88	44	3406

Optional Wheels

1.		2.	
3.		1. Adjustable skids 2. Rear Roller 3. Gauge Wheels	

Vison California



Vison California 2700	105"	70-160	105"	28	2550
Vison California 3200	125"	70-160	125"	34	2890
Vison California 3600	144"	70-160	144"	40	3696
Vison California 4000	158"	70-160	158"	44	3327

Blade Options

Type 1 Blade		Type 2 Blade	
Type 3 Contour Blade		Type 4 Hammer	
Type 5 Blade		Type 9 Blade	

Optional Equipment

- Hammers and smooth counterblade in lieu of std
- #3 or #9 blades w/ smooth counterblade in lieu of std
- 540 rpm PTO in lieu of std
- Adjustable skids

FALC SHREDDERS

Kronos Shredder



- HD Series PTO Shaft
- Replaceable wear sheets
- Interchangeable blades. Type 1 is standard
- Two adjustable gauge wheels on 4000, 4800, & 5400. Four wheels on 6400 & 8000
- Dual Belt Drive.
- Gearbox with internal flywheel.
- 4 belts per side on 4000; 5 belts per side on 4800 thru 6400; 6 belts per side on 8000.
- 2nd set of cutter bars



Dual Belt Drive

Belt drive system with adjustable automatic belt tensioner. Safety cover swings open with just a pull of a pin.

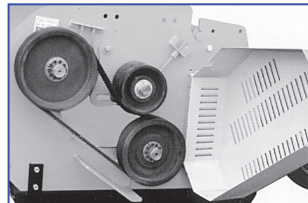

Kronos Rotor

Precision balanced for smooth operation. Rotor diameter is 12". Pictured is the dual rotor of 4800 and larger model sizes.

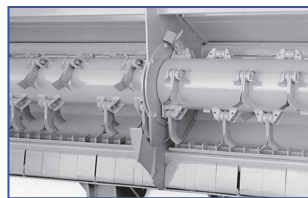

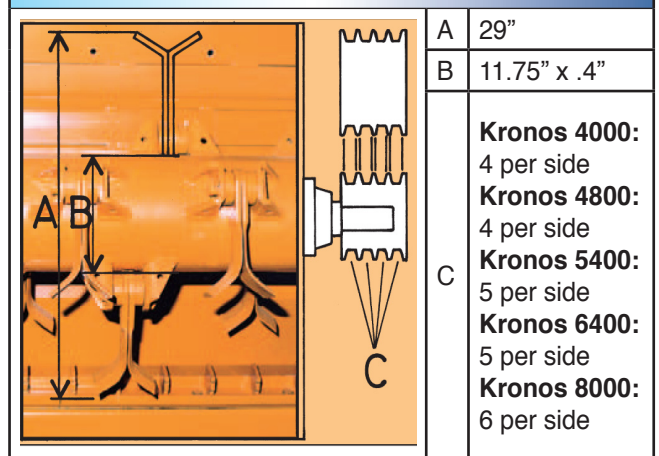

Kronos Drive and Rotor

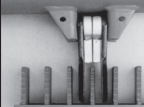
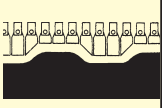

SHREDDER

Blade Options

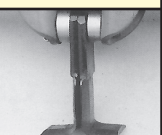
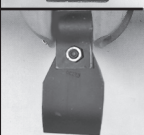
Type 1 Blade		Type 2 Blade	
Type 3 Contour Blade		Type 4 Hammer	
Type 5 Blade		Type 9 Blade	

Model No.	Width	Blades	Tractor HP	Wt (lbs)
Kronos 4000 DT/MR	158"	88	100-160	5500
Kronos 4800 DT/2R	190"	104	100-160	6204
Kronos 5400 DT/2R	215"	120	120-180	7260
Kronos 6400 DT/2R	250"	144	120-180	8404
Kronos 8000 DT/2R	314"	176	160-280	10186

FALC SHREDDERS

Kronos 6000/P Hydraulic Folding Shredder



SHREDDER

The Kronos 6000/P provides all the advantages of the Heavy Duty Kronos shredder plus hydraulic folding for narrow transport width. The Kronos 6000/P is particularly suited for 3 - 80 inch or 3 - 84 inch beds (requires optional folding wheels).

See previous page for additional Kronos specs.

Standard Equipment:

- Double belt drive with automatic belt idler.
- Interchangeable blades. Type 1 is standard
- Adjustable gauge wheels
- Gearbox with internal flywheel.
- 5 belts per side

Model No.	Width	Blades	HP Req.	Weight
Kronos 6000/P	240"	136	120-180	7165 lbs

Blade Options

Type 1 Blade		Type 2 Blade	
Type 3 Contour Blade		Type 4 Hammer	
Type 5 Blade		Type 9 Blade	

FALC SHREDDERS

Pellicano and Super Pellicano Articulating Shredder

The Pellicano chops grass, bushes, & branches on roadsides, the banks of ditches and canals. It pivots through an arc of 150°, retracts directly behind the tractor, and swings out to one side. If an obstacle is contacted, a safety system allows the shredder to pivot clear, then automatically resets. Super Pellicano model has gearbox outboard of belt drive for even greater swing angle



Standard Features:

- Gearbox with internal freewheel
- 540 rpm pto
- Rear closing hood
- For tractors 80-110 hp.



SHREDDER

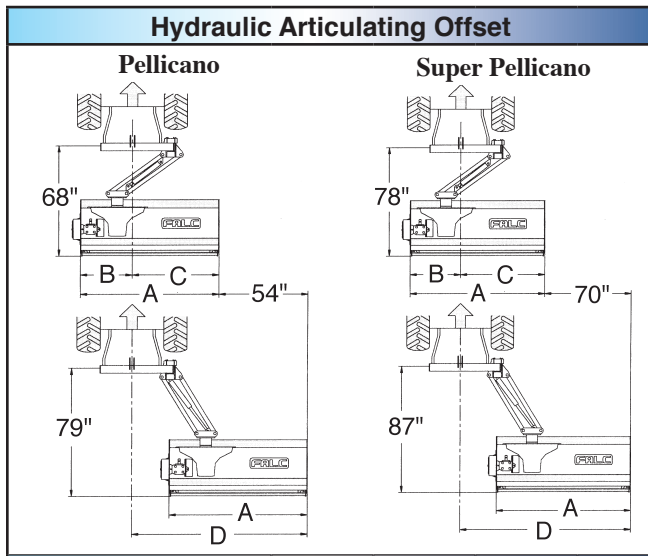

Model	A	B	C	D
Pellicano 1600	63"	31"	31"	86"
Pellicano 1800	70"	31"	39"	93"
Pellicano 2100	84"	31"	53"	107"
S. Pellicano 1600	63"	21"	42"	112"
S. Pellicano 1800	70"	21"	49"	118"
S. Pellicano 2100	84"	21"	63"	133"



Transport Position

Pellicano retracted directly behind the tractor for rear mowing and transport.



Hydraulic Offset

Pellicano offsets to one side. An automatic system pivots shredder clear of obstacles.

Model No.	Cutting Width	No. of Hammers	Weight (lbs)
Pellicano 1600	63"	16	1654
Pellicano 1800	70"	18	1742
Pellicano 2100	84"	22	1874
S. Pellicano 1600	63"	16	1874
S. Pellicano 1800	70"	18	2028.
S. Pellicano 2100	84"	22	2160
S. Pellicano 2500	98"	26	2491

FALC SHREDDERS

Solex & Vortex Shredder with Hydraulic Dumping Hopper



Standard Features:

- Solex is suited to the shredding of grass & light vineyard prunings.
- Vortex shreds material up to light orchard prunings as well as grass & vineyard prunings
- 540 rpm pto
- Maximum dumping height of 80"
- Rear roller
- Threaded hammer support pin with self-locking nut.

SHREDDER



Rotor and Drive Information

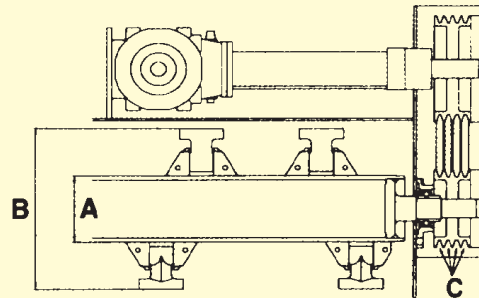

	Solex	Vortex
A	5.5" x 3/8" wall	7.6" x 3/8" wall
B	17"	24.5"
C	4 belts	4 belts



Model	Description	HP req.	Wt (lbs.)	Hopper Capacity
Solex 1800	71" cutting width shredder	80-90	2403	2.43 cu. yd.
Vortex 2100	84" cutting width shredder	100-140	3153	3.05 cu. yd.

Optional Equipment

Front Wheels (pr)
Skids (pr)
Rear rake tines
Entry guide

PRONOVOST SNOWBLOWERS

Lynx Homeowner Snowblower



Standard Features:

- Balanced auger protected by shear bolt.
- Adjustable skid shoes.
- Reinforced 4 bladed rotor.
- Roller bearings encased in ductile cast iron.
- Main heavy duty PTO shaft protected by shear bolt.
- Chute base on antifriction blocks or ring.

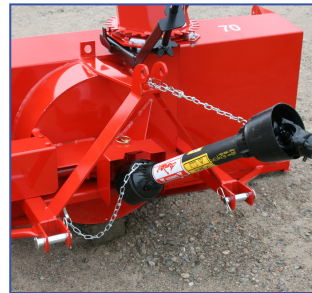

Options:

- **Chute Rotation:** manual, hydraulic cylinder, or electric motor.
- **Chute Deflector:** manual, hydraulic cylinder, or electric actuator



Model	LYNX-52	LYNX-62	LYNX-70
HP	16-25	16-25	16-25
Working width	52"	62"	70"
Cutting height	25"	25"	25"
Drum diameter	21"	21"	21"
Depth of drum	6"	6"	16"
Impeller blades	4	4	4
Impeller shaft diameter	1"	1"	1"
Impeller center height	13"	13"	13"
Impeller RPM	540	540	540
Number of augers	1	1	1
Main auger diameter	14"	14"	14"
Drive chain	50	50	50
Hitch category	1	1	1
Standard Drive shaft	T20	T20	T20
Weight complete with chute	322	339	353

PRONOVOST SNOWBLOWERS

Puma Homeowner Snowblower



- Balanced auger protected by shear bolt.
- Adjustable skid shoes.
- Reinforced 4 bladed rotor.
- Roller bearings encased in ductile cast iron.
- Main heavy duty PTO shaft protected by shear bolt.
- Chute base on antifriction blocks or ring.
- Inverted series has same features as standard Puma, plus the chute rotation kit for hydraulic motor.



Model	Puma Standard 3-pt Models								Puma Inverted 3-pt Models			
	PUMA 48	PUMA 54	PUMA 64	PUMA 72	PUMA 74	PUMA 84	PUMA 94	PUMA 96	PUMA 64IV	PUMA 72-IV	PUMA 74-IV	PUMA 80-IV
HP	16-25	16-25	18-30	20-35	25-40	40-75	50-75	80-125	18-35	18-35	35-60	35-60
Working width	48"	54"	64"	72"	74"	84"	94"	96"	64"	72"	74"	80"
Cutting height	25"	25"	26.5	26.5	30"	34"	34"	38"	29"	29"	31"	31"
Drum dia.	21"	21"	22"	22"	24"	28"	28"	32"	24"	24"	26"	26"
Drum depth	7"	7"	7"	7"	8"	11"	11"	11"	7"	7"	9"	9"
Impeller blades	4	4	4	4	4	4	4	5	4	4	4	4
Impeller shaft dia.	1"	1"	1.25"	1.25"	1.6"	1.6"	1.6"	2"	1.25"	1.25"	1.6"	1.6"
Impeller rpm	540	540	540	540	540	540	540	540	540	540	540	540
Number of auger	1	1	1	1	1	1	1	1	1	1	1	1
Auger dia.	16"	16"	16"	16"	17"	20"	20"	23"	15"	15"	16"	16"
Drive chain	50	50	50	50	60	60	60	80	50	50	60	60
3-pt Cat.	1	1	1	1	1 & 2	1 & 2	1 & 2	2	1	1	1	1
Chute base antifriction	Blocks	Blocks	Blocks	Blocks	Ring	Ring	Ring	Ring	Blocks	Blocks	Ring	Ring
Drive shaft	T20	T20	T20	T40	T40	T50	T60	T80	T40	T40	T50	T50
Weight w/ chute	366	374	413	430	639	955	98	1300	470	502	702	724

PRONOVOST SNOWBLOWERS

Group I Professional-Grade Snowblowers



54 to 80" Width, 18 to 70 HP PTO

- Automatic double chain binder.
- Quick adjust skid shoes.
- Adjustable 3 point hitch.
- Robust reinforced sides.
- Lighter balanced rotor which is stronger and more efficient. Auger is also balanced
- Roller bearing encased in ductile cast iron.
- Bolted rotating drum mounted on UHMW bearing
- Hydraulic motor drum rotation and chute rotation kit (without motor).

Model	P-540	P-620	P-680	P-720
Cutting width	54"	62"	68"	72"
Cutting height	28"	28"	30"	30"
Tractor hp	18-25	20-30	25-40	25-50
Depth of drum	9"	9"	9"	9"
Impeller dia.	22"	22"	24"	24"
Impeller blades	4	4	4	4
Impeller shaft	1.25"	1.25"	1.6"	1.6"
Impeller rpm	540	540	540	540
Impeller Height	14"	14"	15"	15"
No. of Augers	1	1	1	1
Auger dia.	16"	16"	16"	19"
Chain size	50	50	60	60
Hitch cat	1	1	1	1
Shear Bolts	2	2	2	2
P.T.O driveline	No. 2	No. 2	No. 4	No. 5
Weight (lbs.)	550	575	670	695

Model	Description
Group I Snowblowers;	
P-540	54" Commercial snowblower
P-620	62" Commercial snowblower
P-680	68" Commercial snowblower
P-720	72" Commercial snowblower
P-720TRC	72" Commercial snowblower w/ rotating drum, side deflector
Chute Options, Deflectors, and Rotation Kits	
CST-4872	Reg. chute
PSIG-5472	Semi-Industrial Chute
T-4864	Manual telescopic tube for chute deflector
25TR04	Hyd. cylinder for telescopic chute deflector
TSB-4864	Hose support for deflective cylinder
MR-4864	Manual chute rotation kit.
SP-4864	Hydraulic chute rotation kit
MLH-125	Motor for kit (for pump less than 120GPM)
MLH-250	Motor for kit (for pump more than 10 GPM)
Heavy Duty Options	
SIT1-54	Semi-industrial scraper blade, 3/8" x 2-1/2" not sharpened: fits 540
SIT1-62	Semi-industrial scraper blade, 3/8" x 2-1/2" not sharpened: fits 620
SIT1-68	Semi-industrial scraper blade, 3/8" x 2-1/2" not sharpened: fits 680
SIT1-72	Semi-industrial scraper blade, 3/8" x 2-1/2" not sharpened: fits 720(TRC)
PHD-4872	Industrial skid shoes. CHT-360 steel sole
CL-4872	Set of lateral blades (3/8" x 2.5" x 39.5")

PRONOVOST SNOWBLOWERS

Group II Professional Grade Snowblowers

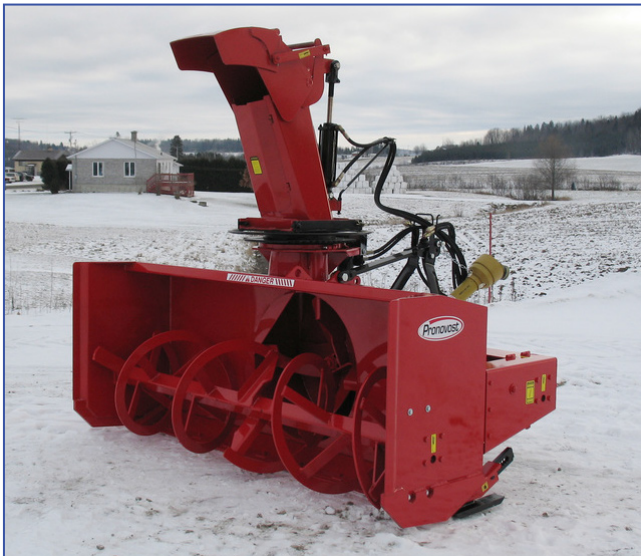

74 to 98" Width, 50 to 125 HP PTO

- Balanced auger.
- Automatic double chain binder.
- Quick adjust skid shoes.
- Adjustable 3 point hitch.
- Robust reinforced sides.
- Lighter balanced rotor which is stronger and more efficient.
- Roller bearing encased in ductile cast iron.
- Removable scraper blade set on a 6 degree angle and reversible.
- Bolted rotating drum (thereby removable) mounted on UHMW bearing (TRC).
- Hydraulic motor drum rotation.
- Hydraulic motor chute rotation kit (without motor).
- Chute rotation on antifriction ring.



Two-Auger Model '2'

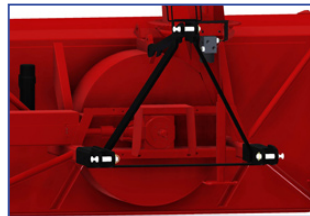

TRC Rotating drum



Hydraulic Deflector



Chute Rotation

Model	740	800	860	862	920
Cutting width	75"	80"	86"	86"	92"
Tractor hp	35-65	40-65	50-75	50-75	75-100
Cutting height	33.5"	33.5"	35.5"	41.5"	39"
Depth of drum	12"	12"	12"	12"	12"
Impeller dia.	26"	26"	28"	28"	30"
Impeller blades	4	4	4	4	5
Impeller shaft	1.6"	1.6"	1.6"	1.6"	2"
Impeller rpm	540	540	540	540	540
No. of augers	1	1	1	2	1
Auger dia.	23"	23"	23"	13"/23"	23"
Chain size	80	80	80	80	80
Hitch cat	I & II	I & II	I & II	I & II	II
P.T.O driveline	no. 5	no. 5	no. 6	no. 6	no. 8
Weight (lbs.)	1190	1235	1294	1475	1650

Model	Description
P-740	74" commercial snowblower
P-800	80" commercial snowblower
P-800TRC	80" commercial snowblower w/ rotating drum, side deflector
P-860	86" commercial snowblower
P-860TRC	86" commercial snowblower w/ rotating drum, side deflector
P-862	86" commercial snowblower
P-862TRC	86" commercial snowblower w/ rotating drum, side deflector
P-920	92" commercial snowblower
P-920TRC	92" commercial snowblower w/ rotating drum, side deflector
P-920-98	92" commercial snowblower
P-920TRC-98	92" commercial snowblower w/ rotating drum, side deflector

PRONOVOST SNOWBLOWERS

Group III Professional Grade Snowblowers



98 to 108" Width, 100 to 150 HP PTO

- Balanced auger.
- Automatic double chain binder.
- Quick adjust skid shoes.
- Adjustable front 3 point hitch.
- Robust reinforced sides.
- Lighter balanced rotor which is stronger and more efficient.
- Roller bearings encased in ductile cast iron.
- Removable scraper blade set on a 6 degree angle and reversible.
- Optional upper auger.
- Bolted rotating drum (thereby removable) mounted on UHMW bearing (TRC).
- Hydraulic motor drum rotation.
- Hydraulic motor chute rotation kit (without motor).
- Chute rotation on antifriction ring.

Model	P-992	P-980	P-1040
Cutting width	92"	98"	104"
Cutting height	44.5"	48"	48"
Tractor hp	75-125	100-150	100-150
Depth of drum	15"	15"	15"
Impeller dia.	23"	26"	26"
Impeller blades	5	6	6
Impeller shaft	2"	2"	2"
Impeller rpm	540	540	540
Impeller Height	19.5"	21.5"	21.5"
No. of Augers	2	2	2
Auger dia.	23"	26"	26"
Chain size	80	100	100
Hitch cat	II	II	II
Shear Bolts	2	2	2
P.T.O driveline	No. 8	No. 8	No. 8
Weight (lbs.)	1843	2003	2063



Upper Auger Kit



Quick-Adjust Skids

Model	Description
P-992	92" commercial snowblower
P-992TRC	92" commercial snowblower with rotating drum, side deflector
P-980	98" commercial snowblower
P-980TRC	98" commercial snowblower with rotating drum, side deflector
P-1040	104" commercial snowblower
P-1040TRC	104" commercial snowblower with rotating drum, side deflector
Chute & Drum Options:	
PSIG-92104	Semi-Industrial chute
PCG-92104	Quick-attach industrial chute
PRP-92104-2	24" extension for industrial chute
PRP-92104	48" extension for industrial chute
PCT-92104	Hydraulic telescopic industrial chute
25TR08	Hydraulic cylinder for chute
MLH-250	Motor: chute rotation (under 12 gpm)
MLH-315	Motor: chute rotation (over 12 gpm)
MLH-250	Motor for drum rotation (under 12 gpm)
MLH-315	Motor for drum rotation (over 12 gpm)
Upper Auger - 14" Diameter (Including accessories)	
VS2-992	Upper auger kit: P-992 & P-992TRC
VS2-980	Upper auger kit: P-980 & P-980TRC
VS2-1040	Upper auger kit: P-1040 & P-1040TRC

PRONOVOST SNOWBLOWERS

X-Pro Front or Rear Mount Snowblower



- Balanced auger.
- Automatic double chain binder.
- Quick adjust skid shoes.
- Adjustable 3 point hitch.
- Reinforced sides.
- Lighter balanced rotor which is stronger and more efficient.
- Roller bearing encased in ductile cast iron.
- Removable cutting edge set on a 6° angle and reversible on certain models.
- Chute with greasable hinges and removable access panel.
- Chute rotation on antifriction ring.



SNOW

Model	PXPL 80	PXPL 86	PXPL 86-92	PXPL 92	PXPL 92-98
HP PTO	40-60	50-75	50-75	75-125	75-125
Working width	80"	86"	92"	92"	98"
Cutting height	28"	28"	28"	34"	34"
Drum diameter	26"	28"	28"	32"	32"
Depth of drum	10½"	12"	12"	12"	12"
Impeller blades	4	4	4	5	5
Impeller shaft diameter	1.6"	1.6"	1.6"	2"	2"
Height - impeller center	16.5"	16"	16"	18.25"	18.25"
Impeller RPM	540	540	540	540	540
No. of auger	1	1	1	1	1
Main auger dia.	16"	16.5"	16.5"	19.5"	19.5"
Drive chain	50	80	80	80	80
Hitch category	1	2	2	2	2
PTO shaft	T50	T60	T60	T80	T80
Weight (lbs)	1215	1861	1915	2114	2154

Model	Description	Wt.
PXPL-86	86" X-Pro snowblower	1822 lbs
PXPL-86-92	86" X-Pro snowblower	1860 lbs
PXPL-92	92" X-Pro snowblower,	2059 lbs
PXPL-92-98	92" X-Pro snowblowe	2099 lbs
Chutes and Deflectors		
CST-7486	Reg. chute	
PSIG-7486	Semi-industrial chute w/ greasable hinges & rear access panel	
T-74104	Chute deflector adjustment: Manual telescopic tube	
25TR08	Chute deflector adjustment: Hydraulic cylinder	
TSB-74104	Hose support for deflector cylinder	
MLH-250	Hyd. chute rotation motor for (for pump with less than 12 GPM)	
MLH-315	Hyd. chute rotation motor for (for pump with more than 12 GPM)	

ENVIROMIST SPRAYERS

Spraydome Adjustable Width Orchard and Vineyard Sprayers



For treating non-uniform widths or performing multiple spraying tasks.

Spraydome adjustable sprayers treat widths from 5' to 24' in one pass. Variable width and wide reach make them ideal for center row weed control in orchards. They can also be used in vineyards and amenity situations: spraying roadsides, parks and fence lines.



Available in HiFlo and CDA variants, the range comprises of a choice of three variable width base units: the Spraydome 1524 (5'-8'), the Spraydome 2034 (6.5'-11'), and the Spraydome 3049 (10'-16'). For wider center rows, units can be fitted with circular Spraydome 1200 models, extending the coverage by 8'. These extensions incorporate a breakaway arm which allows operators to spray in between and around the base of the trees, as well as the center row simultaneously. Base units can be adjusted to their minimum width and the extension arms fold for storage and transport.



SPRAYER

Model	Spraying Width	Application Rate	Weight
Base Spraydome 1524	Adjustable 5-8'	HiFlo spray head: 10-50 gal/acre CDA spray head: 2-6 gal/acre	222 lbs
Base Spraydome 2034	Adjustable 6.5-11'	HiFlo spray head: 10-50 gal/acre CDA spray head: 2-7.5 gal/acre	385 lbs
Base Spraydome 3049	Adjustable 10-16'	HiFlo spray head: 10-50 gal/acre CDA spray head: 2-6 gal/acre	450 lbs
Spraydome 1200 extension	4' breakaway sprayer extension	HiFlo spray head: 10-50 gal/acre CDA spray head: 2-4 gal/acre	80 lbs

ENVIROMIST SPRAYERS

Spraymiser Rectangular Shield Covered Sprayers



Rectangular shield models are perfect for treating fixed band widths. They may be tractor or ATV mounted and are fully compatible with the circular units.



The oblong Spraymiser is excellent for spraying the center row in vineyards, crops and orchards. The no-drift design and targeted application also make them ideal for amenity situations including roadsides, footpaths and fence lines.

Available in widths from 2' to 8'. All models can be fitted with HiFlo or CDA spray systems. CDA variants feature Micron's recirculation system to reduce chemical waste. Spraymiser 1800, 2000 and 2400 models feature hinged wings for transport and storage.

- Minimised risk of spray drift due to shielded design
- Wide range of working widths
- Traditional hydraulic pressure nozzle or CDA (Controlled Droplet Application) atomiser option for low volume application
- Lightweight, compact and easily fitted
- Compatible with most ATVs, UTVs and tractors

Model	Spray Width	Rate (Gal/Acre)	Weight (lbs)
Spraymiser 600 HiFlo	24"	10 – 50	18
Spraymiser 600 CDA	24"	2 – 5	18
Spraymiser 1200 HiFlo	48"	10 – 50	26
Spraymiser 1200 CDA	48"	2 – 4	26
Spraymiser 1500 HiFlo	60"	10 – 50	31
Spraymiser 1500 CDA	60"	2 – 5	31
Spraymiser 1600 HiFlo	63"	10 – 50	35
Spraymiser 1600 CDA	63"	2 – 5	35
Spraymiser 1800 HiFlo	71"	10 – 50	40
Spraymiser 1800 CDA	71"	2 – 5	40
Spraymiser 2000 HiFlo	78"	10 – 50	42
Spraymiser 2000 CDA	78"	2 – 5	42
Spraymiser 2400 HiFlo	96"	10 – 50	55
Spraymiser 2400 CDA	96"	2 – 8	55

ENVIROMIST SPRAYERS

Undavina Circular Shield Spray Heads for Vineyards & Orchards



The Undavina has been specifically developed for treating weeds in vineyards and orchards. The sprayer has a dome-shaped brush design which rolls closely around the base of vines and trees to ensure maximum weed kill. The flexibility afforded by the soft brushes also makes the sprayer suitable for use in young plants where an optional vinyl slip on cover is recommended to protect the sensitive stems from chemical contact.

Available in HiFlo and CDA options, the Undavina can be supplied in 10", 16", 24" and 36" diameters to suit the row spacing or treatment width required.

Optional vinyl brush cover available for added protection.

Model	Spray Width	Rate USG/Acre	Wt (lbs)
Undavina 250 HiFlo	10"	10 - 50	33
Undavina 250 CDA	10"	2 - 8	33
Undavina 400 HiFlo	16"	10 - 50	37
Undavina 400 CDA	16"	2 - 8	37
Undavina 600 HiFlo	24"	10 - 50	40
Undavina 600 CDA	24"	2 - 8	40
Undavina 900 HiFlo	36"	10 - 50	42
Undavina 900 CDA	36"	20 - 50	42

Spraydome Circular Shield Spray Extensions



Incorporating a flexible plastic dome to fully contain spray, circular Spraydome models are ideal for applications where chemical contact with the crop is not desired. In addition to providing a physical barrier to the spray, the hard wearing shields offer durability and longevity in application and make the sprayer particularly suited for more demanding spraying tasks including weed control round trees as well as amenity areas such as fence lines, footpaths and along buildings. Sprayer can also be used for field margin demarcation and agricultural trial plots.

Available in 16", 24", 40" and 48" diameters, all of which can be fitted with either Micron CDA or HiFlo systems.

Model	Spray Width	Rate Gal/Acre	Wt lbs
Spraydome 400 HiFlo	16"	10 - 50	37
Spraydome 400 CDA	16"	2 - 8	37
Spraydome 600 HiFlo	24"	10 - 50	40
Spraydome 600 CDA	24"	2 - 8	40
Spraydome 1000 HiFlo	40"	10 - 50	53
Spraydome 1000 CDA	40"	2 - 5	53
Spraydome 1200 HiFlo	48"	10 - 50	80
Spraydome 1200 CDA	48"	2 - 4	80

ENVIROMIST SPRAYERS

Varidome Shielded Row Crop in-Row Sprayer

Specifically designed for eradicating weeds growing in between the rows, Varidome can be used in a wide variety of crops.



The sprayer is available in up to 40' working widths. The 10 foot S1 is available HiFlo or CDA. Larger models are fitted with hydraulic pressure nozzles. Shields are mounted on individually floating carriages to minimise drift.

Four types of oval shields are available. Rotating circular shields may also be used along bed sides or wherever breakaway is required. Optional dual spray system allows application of one product in between rows and different product directly over the row.

SPRAYER

Model	Total Spray Width	Rate (gal/acre)	Implement Requirements	Mount	HP Req.
Varidome S1	up to 10'	CDA:2-5 HF:10-50	12v 3A 1 hydraulic service	3-pt Cat 2 front/rear	50
Varidome S3	up to 20'	10-50	12v 3A power; 3 hydraulic services	3-pt Cat 2 front/rear	100
Varidome S5	up to 30'	10-50	12v 3A power 3 hydraulic services	3-pt Cat 2 front/rear	120
Varidome S7	up to 40'	10-50	12v 3A power; 3 hydraulic services	3-pt Cat 2 front/rear	180
Shield	In-row Width	Rate (gal/acre)	Spray System	Carriage	Toolbar
Varidome 80	3 - 32"	2-5	CDA atomiser	LW	S1
Varidome 130	5 - 32"	2-5	CDA atomiser	LW	S1
Varidome 170	7 - 28"	10-50	Hyd. nozzle	LW/HD	S1-S7
Varidome 100	4 - 18"	10-50	Hyd. nozzle	LW/HD	S1-S7
Varidome 250	10"	10-50	Hyd. nozzle	LW/HD	S1-S7
Varidome 400	16"	10-50	Hyd. nozzle	LW/HD	S1-S7
Varidome 600	24"	10-50	Hyd. nozzle	LW/HD	S1-S7

ENVIROMIST SPRAYERS

100L Tractor-Mount Tank System



- Micron Tank System 100L can be used with the complete range of Micron shielded CDA and high flow equipment. Intelligent attachment positioning allows machinery to be set up to suit individual operations, mounted front or rear.
- The modular design does not require the use of a PTO or hydraulics, just a single 12 volt (3 amp) electrical supply reducing operator risk of injury.
- When used with CDA low volume machinery, the Tank System 100L can further increase productivity through reducing filling time which means more time can be spent spraying.
- In addition to the 100 litre mixed chemical tank, the Tank System features two separate 15 litre tanks carrying clean fresh water for rinsing the system and operator hand washing. Flushing the system out after spraying is as simple as turning a tap, with ample supply to thoroughly cleanse the main tank and any connected machinery of chemicals.
- The pumping system contains the features that would be expected of any professional sprayer. All fluids are filtered and an agitation system ensures complete chemical mixing before spraying.

60L and 80L ATV Mount Tank System

- Available in 60 or 80 litre capacity, the MicronTank System can help increase the productivity of your spraying operation and reduce the time spent at the refill point.
- 3.5L Flush tank provides ample liquid for the lines to be thoroughly cleansed of chemicals. It's quick, simple, effortless, and allows you to quickly get on with more profitable tasks.
- Remco Pump for reliable performance
- Unit can deliver up to 300 litres per hour - sufficient capacity for spot spraying, low volume and CDA use. The pump is housed for maximum protection, yet still easily accessible for maintenance.
- Designed for practicality, durability and comfort
- Molded from heavy duty plastic for a maintenance free long life. Designed to shape around the driver for greater comfort. The overall design achieves capacity yet keeps a low, sleek profile.
- Fits most ATV and UTV models
- The tank is light and easy to handle and can be quickly mounted or removed. Coupling to a sprayer unit is simple.



SPRAYER

PROJET SPRAYERS

Compact Air Control Pull Type Air Blast Spreader



- 286 to 858 gallon poly tank.
- Rinse tank and handwash tank.
- External sight gauge.
- Double brass spray nozzles.
- Two speed fan with adjustable pitch blades.
- Two fans: one with reverse rotation.
- Adjustable width axles.
- Electric spray control.

Model	Tank (Gal)	HP	Fan Dia	Nozzles	Air flow (CFM)	Vert Distance	Wt (lbs)
1100	286	65 - 75	32"	14	40 - 58,000	33 ft	1320
1650	429	70 - 80	32"	14	40 - 58,000	33 ft	1628
2200	572	75 - 85	32"	14	40 - 58,000	33 ft	1760
3300	858	100	36"	14	44 - 59,000	39 ft	2156

Compact Control Pull-Type Airblast Sprayer

- 170 to 850 gallon poly tank
- Rinse tank and hand wash tank
- External sight gauge
- Double brass spray nozzles
- Two speed fan with adjustable pitch blades
- Adjustable width axles.
- Electric controlled spray
- Air shutoff caps to direct air flow.



Model	Tank (Gal)	HP	Fan Dia	Fan Blades	Nozzles	⚙️	Vol.	Tire Size	Wt (lbs)
660	175	30-40	28"	12	10	2	21286	185/60R14	1210
880	233	30-40	28"	12	10	2	17655	185/60R14	1364
1100	290	40-50	32"	10	12	2	19420	10.0/80-12	1518
1650	436	50-70	32"	10	12	2	19420	10.0/80-12	1650
2200	581	70-80	35"	10	12	2	19420	11.5/80-15.3	1716
3300	872	80-90	35"	10	12	2	19420	11.5/80-15.3	2046

PROJET SPRAYERS

Compact Bi Control Pull-Type Airblast Sprayer

- Polyethylene main tank, rinse tank, and hand wash tank
- External tank and oil site gauges
- Painted steel frame with height & width adjustable axles. Parking stand and tail lights standard.
- No-drip nozzles
- Two speed gearbox with neutral.
- Two variable pitch fans with clutch. One has reverse rotation.
- On-off electric control
- Double Jet agitator
- Pumps available from 16 to 36 gpm with spray pressure 10 to 736 psi



Model	Tank Gal	HP	Fan Dia	Fan Blades	Nozzles	⚙️	PTO RPM	Vol. ft ³ /min	Spray Dist (ft.)	Tire Size	Dimensions (inches)			Wt (lbs)
											W	L	H	
1100	290	65-75	31.5"	10	10	2	540	57700	33	10.0/80-12	51	118	47	1320
1650	436	70-80	31.5"	10	10	2	540	57700	33	10.0/80-12	55	140	51	1628
2200	581	75-85	32.5"	10	12	2	540	57700	33	11.5/80-15.3	55	140	57	1760
3300	872	100	35.4"	10	12	2	540	57700	40	11.5/80-15.3	75	156	79	2156

Mix Control Sprayer

- Single & two speed gearbox
- Adjustable pitch fan blades
- Choice of 28", 32", & 36" fans.
- 10 year warranty on poly tank
- Rinse tank and hand wash tank.
- Jet agitation.
- Double brass nozzles.
- Optional mixing basket.



Model	Tank (Gal)	HP	Fan Dia	Fan Blades	Nozzles	⚙️	Spray Distance	Wt (lbs)
660	172	30-40	28"	8	10	2	13 - 16	1210
880	229	30-40	28"	8	10	2	13 - 16	1364
1100	286	40-50	32"	10	12	2	16 - 20	1518
1650	429	50-70	32"	10	12	2	16 - 20	1650
2200	572	70-80	36"	10	12	2	20 - 23	1716
3300	858	80-90	36"	10	12	2	20 - 23	2046

PROJET SPRAYERS

Mix Venturi Sprayer

The ProJet Mix sprayer features a 20" fan with clutch assembly, capable of delivering 9000 cubic feet a minute of air volume for even coverage.

It has a polyethylene tank, available in 80-160 Gallon capacities with a 10 year warranty. Tanks have an external fill indicator. Separate circuit and hand wash tanks are also included.

Two speed gearbox allows you to choose the right air volume for your conditions.

Designed for 3 pt mounting for 50-65 horsepower tractors.



Model	Tank (Gal)	HP	Fan	Speeds	RPM	Wt
330	80	50-55	20"	2	540	456
440	105	55-60	20"	2	540	500
660	160	60-85	20"	2	540	545

Star Mixer Airblast Sprayer



The ProJet Star Mixer is a three-point mount sprayer designed for use with 20-40 hp tractors. The polyethylene tanks are available in 50-105 Gallon capacities and feature hydraulic agitators and external fill indicators. It also has a cleaning tank, as well as a hand-wash tank.

A Large 20" nylon fan is driven by your 540 rpm PTO. It has 12 blades and delivers 15,000 cfm of air volume.

The ProJet Star Mixer has ten no-drip brass dual nozzle assemblies. Other plumbing features include pressure regulator valve with adjustable 3-way distributor.

Model	Tank	HP	Fan	Speeds	RPM	Wt (lbs)
200	50 G	25-30	20"	1	540	401
330	80 G	25-30	20"	1	540	445
440	105 G	30-40	20"	1	540	490

PROJET SPRAYERS

Compact Venturi Pull-Type Sprayer



- Polyethylene main tank with 10 yr warranty. Hand-wash and rinse tank standard.
- External tank and oil sight gauge.
- Painted steel frame with parking stand. Axles are adjustable for both height and width, and wheel tongue jack is standard on 1650/2200
- Double jet agitator, self-filling intake filter, and fully adjustable nozzles.
- Centrifugal fan with clutch driven by two speed overdrive gear.
- On-off electrical control
- Light Kit

Spray Head Configurations

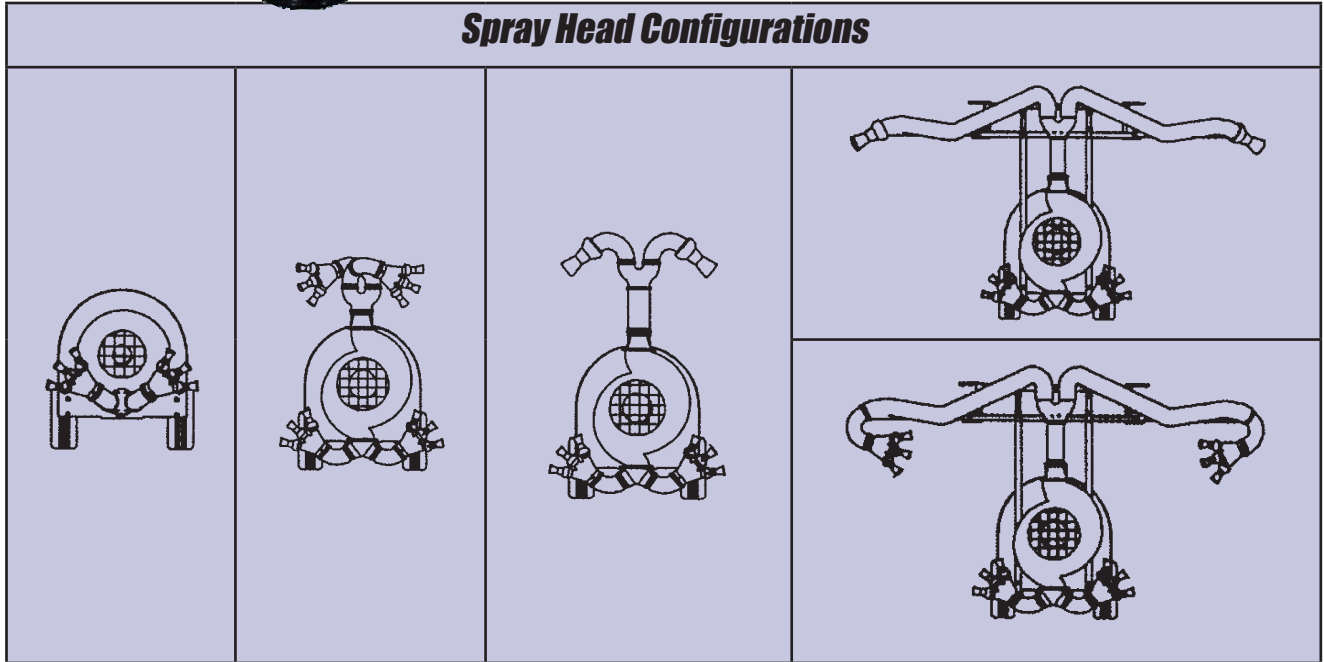

Model	Tank Gal	HP	Fan	Speeds	PTO RPM	Air vol (ft ³ /min)	Air spd (mph)	Tire Size	Width (in)	Length (in)	Height (in)	Wt (lbs)
660	175	45-55	20"	2	540	8830	325	185/60 R14	55.1	100	45	968
880	233	50-60	20"	2	540	8830	325	185/60 R14	55.1	100	46	979
1100	290	60-70	20"	2	540	8830	325	10.0/80-12"	55.1	108	47	1210
1650	436	70-75	20"	2	540	8830	325	10.0/80-12"	55.1	130	51	1518
2200	581	80-90	20"	2	540	8830	325	11.5/80-15.3"	55.1	130	51	1716

PROJET SPRAYERS

Turbo Mix Flex Cannon Sprayer



- Up to 109 feet horizontal spray
- Up to 108 feet vertical spray
- 18" double vane fan
- Two Speed Gearbox
- No drip nozzles
- Jet agitator

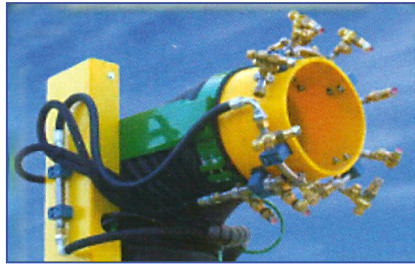
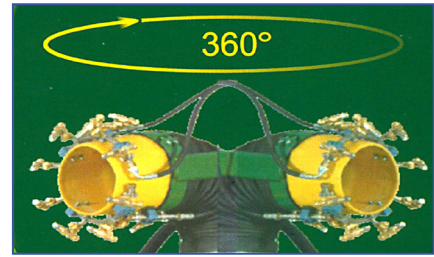

Model	Tank (Gal)	HP	Horz.	Vert.	Wt (lbs)
660	172	50-70	66 - 82' 105 - 118'	49 - 59' 95 - 108'	1157
880	229	50-70	66 - 92' 105 - 118'	49 - 59' 95 - 108'	1184
1100	286	50-70	66 - 92' 105 - 118'	49 - 59' 95 - 108'	1201

Compact Air System Airblast Sprayer for Small Trees and Vineyard

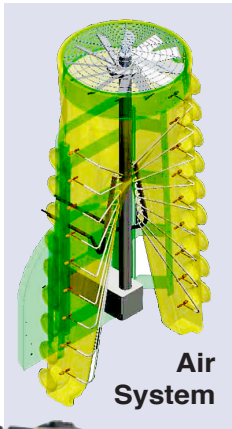

- Polyethylene tank with 10-year warranty. Polyethylene hand wash and rinse tank are standard.
- External tank and oil level site gauges
- Painted steel frame with height and width adjustable axles. Parking stands, front and rear, and tail lights standard.
- Patented 'air system' fan with 9 outlets per side
- Two speed reverse gearbox.
- 32" fan with twelve variable pitch fan blades
- On-off Electric Controls.
- Four closing caps.
- Double jet agitators on 1650-3300

Model	Gal	HP	Air Vol ft ³ /min	Spray Dist.	Tire Size	Wt (lbs)
1100	290	60-80	29800	26-33'	10.0/ 80-12	1320
1650	436	60-80	29800	26-33'	10.0/ 80-12	1628
2200	581	80-100	35100	33-39'	11.5/ 80-15.3	1826
3300	872	80-100	35100	33-39'	11.5/ 80-15.3	2156

SPRAYER

FALC POWER HARROW

Magnum Power Harrow



Packer Roller Option



Cage Roller option

Standard Equipment:

- 1000 rpm pto gearbox with rear pto
- Manual change gears 365 rpm standard
- PTO shaft with torque limiter. Model 3000 yoke: 1-3/8 x 6z; Models 3500-5000 yoke 1-3/8" x 21z
- Front tube 80 x 120 x 6 for extra strength and optional track eliminator
- Rear leveling bar
- Round blade support to accept optional stone guards.

Magnum Rotary Blade

A. Blade thickness 18mm (.71 inches) and blade length 320mm (12.6 inches). Quick blade replacement by removing pin.

B. Heavy duty tapered roller bearings

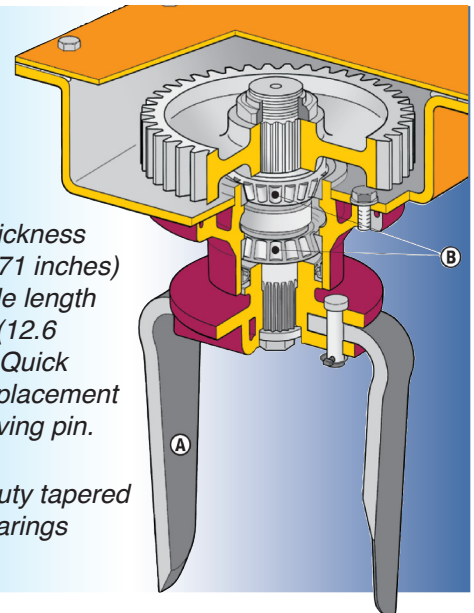

Model	Width (inches)	No. of Rotors	HP	Wt (lbs)
3000	122	12	100-240	3814
3500	142	14	120-240	4453
4000	161	16	130-240	5093
4500	181	18	150-240	5732
5000	200	20	160-240	6371

TILLAGE

FALC SPADERS

Panda Spader

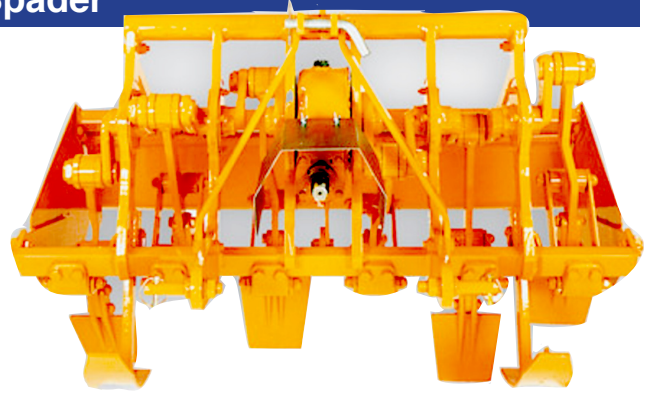

Gearbox model M5.75 - 540 RPM

Pos	Gear Ratio			
	1	○ 16	○ 15	○ 14
2	● 13	● 14	● 15	● 16
rpm	114	130	150	172

- 35 to 58 inch working width
- 4 Speed Gearbox
- For 20 - 35 horsepower Tractors
- PTO shaft Less clutch
- Cage Protection

Tractor must be equipped with creeper gear.

Model No.	Width (in.)	No. of Spades	Digging Depth	HP	Wt (lbs)
1000	35.4	4	8 in.	20-35	495
1300	48	6	8 in.	20-35	682
1500	58	6	8 in.	20-35	724

Optional Equipment:

PTO shaft with clutch

Mini Toro Spader

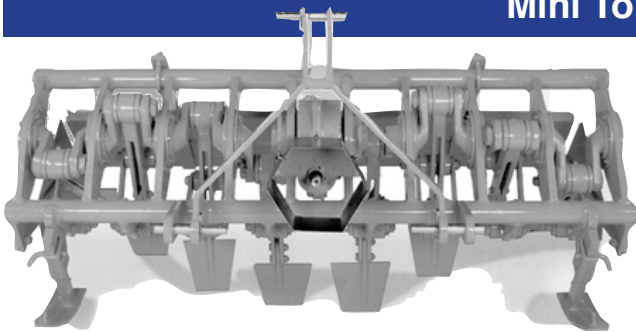

- 40 to 80 inch working width
- 4 Speed Gearbox
- For 30-60 horsepower Tractors
- PTO shaft with clutch
- Cage Protection

Tractor must be equipped with creeper gear

Gearbox model M6.25 - 540 RPM

Pos	Gear Ratio			
	1	○ 16	○ 15	○ 14
2	● 13	● 14	● 15	● 16
rpm	120	140	160	180

Model No.	Width (in.)	No of Spades	Digging Depth	HP	Wt (lbs)
1000	39.5	4	10 in.	30-60	836
1200	50.0	4	10 in.	30-60	869
1300	55.6	6	10 in.	40-60	1056
1500	59.4	6	10 in.	40-60	1100
1700	66.4	6	10 in.	45-60	1144
1800	71.6	8	10 in.	50-60	1298
2000	76.9	8	10 in.	50-60	1342

FALC SPADERS

Toro Spader

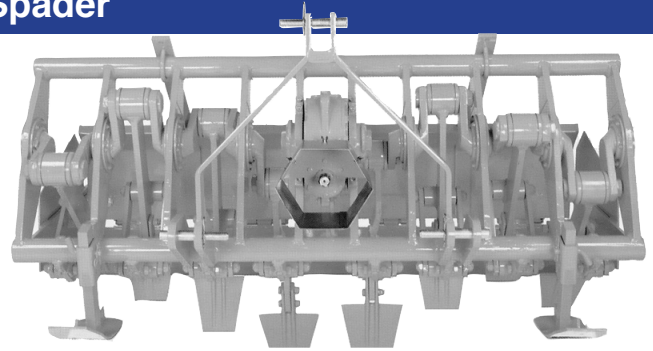

- 50 to 98 inch working width
- For 40-90 horsepower Tractors
- 3 Speed Ranges: 120, 140, & 160 rpm.
- External flanges and cage protection are standard.
- PTO shaft with clutch

Tractor must be equipped with creeper gear

Model No.	Width (in.)	No. of Spades	Digging Depth	HP	Wt (lbs)
1500	59.2	6	14 in.	40-90	1485
1700	66.1	6	14 in.	45-90	1562
1800	71.5	8	14 in.	60-90	1826
2000	77.0	8	14 in.	60-90	1936
2200	87.0	10	14 in.	70-90	2376
2500	97.6	10	14 in.	70-90	2464

Gearbox model M6.25 - 540 RPM				
Pos	Gear Ratio			
	1	○ 16	○ 15	○ 14
2	● 14	● 15	● 15	
rpm	120	140	160	

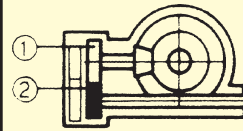

Leopard Spader

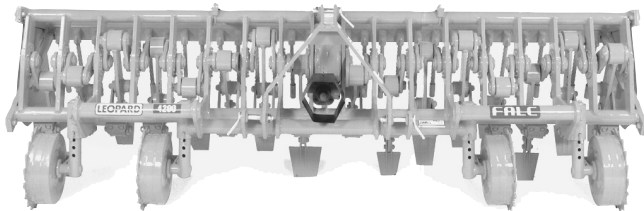

- 100 to 165 inch working width
- For 100-1800 horsepower Tractors
- 2 speeds: 165 OR 187 rpm
- M8 PTO with clutch
- Pair of gauge wheels
- All movement on sealed bearings
- Rear grill, cage protection, & PTO shaft with clutch.

Tractor must be equipped with creeper gear



Pos.	Gear Ratio	
	1	○ 24
2	● 13	● 14
RPM	165	187

Model No.	Width (in.)	No. of Spades	Digging Depth	HP	Wt (lbs)
3200	124.0	12	14 in.	100-180	3784

FALC ROTARY TILLERS

Model A Rotary Tiller



Hitch Offset:

A900

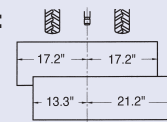

A1100

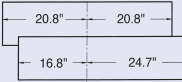

A1250

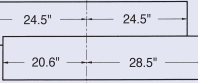

A1450

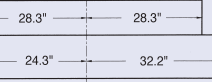

A1650

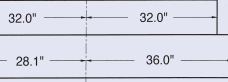

Model	Description	Weight	Blades
A 900	36" Till Width	352	20
A 1100	44" Till Width	374	24
A 1250	50" Till Width	396	28
A 1450	58" Till Width	418	32
A 1650	66" Till Width	440	36

- 30 hp max.
- 540 rpm pto with shear bolt protection
- Low maintenance chain side drive.
- Single speed gearbox; Rotor speed is 312 rpm
- 4 blades per flange
- Depth control skids.

Model B and B Super Rotary Tiller

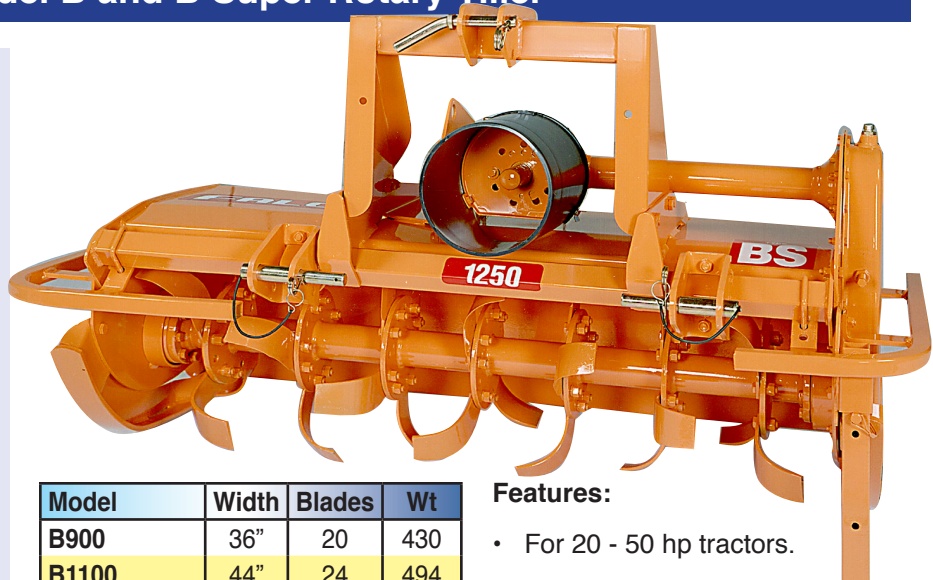

B and B Super Hitch Offset

900

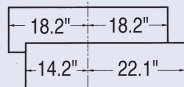

1100

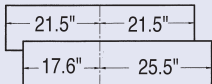

1250

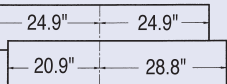

1450

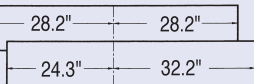

1550

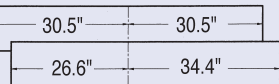

1650



1800

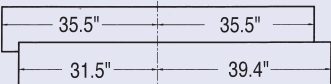

Model	Width	Blades	Wt
B900	36"	20	430
B1100	44"	24	494
B1250	50"	28	516
B1250 Super	42	539	
B1450	58"	32	542
B1450 Super	48	561	
B1550	62"	36	586
B1550 Super	54	605	
B1650	66"	36	608
B1650 Super	54	638	
B1800 Super	72"	60	660

Features:

- For 20 - 50 hp tractors.
- Model B: 4 blades/flange
- Model B Super: 6 blades/flange.
- 540 rpm pto w/ shear bolt
- Rotor speed; 250 rpm.
- Single speed gearbox and chain side drive.
- Depth control skids standard.

FALC ROTARY TILLERS

Model C Rotary Tiller



Standard Equipment:

- For 40 to 70 hp tractors
- Gear side drive
- 540 rpm pto with slip clutch protection. Rotor rpm: 206
- Single speed gearbox
- Six blades per flange.
- Depth control skids.

Model	Description	Wt (lbs)	Blades
CS1300	Rotary Tiller; 52" till width.	836	30
CS1500	Rotary Tiller; 58" till width.	880	36
CS1600	Rotary Tiller; 62" till width.	924	36
CS1800	Rotary Tiller; 72" till width.	990	42
CS2100	Rotary Tiller, 82" till width.	1056	48

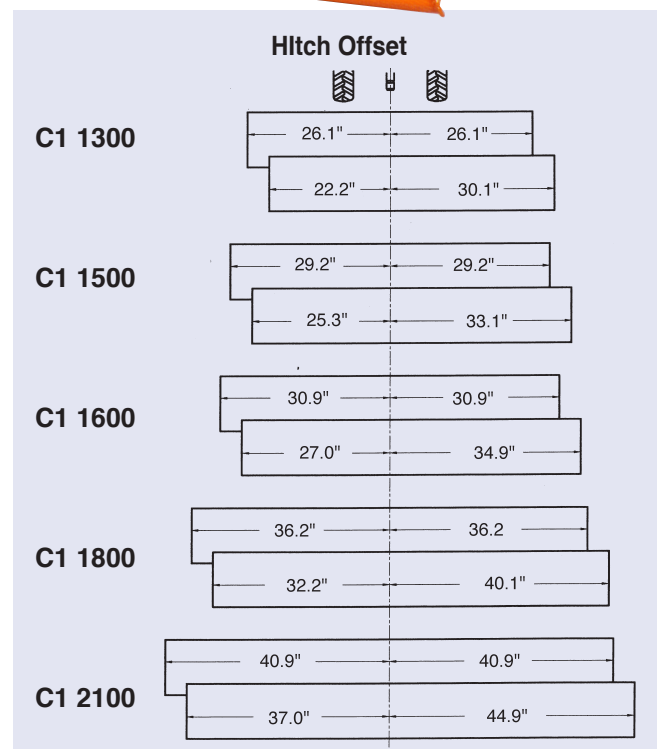

TILLAGE

FALC ROTARY TILLERS

Model D Rotary Tiller



- For 60-100 hp tractors
- D4- 4 speed gearbox.
- Gear side drive.
- Standard pto w/ slip clutch and depth control skids
- 6 blades per flange
- Rotor rpm: D4- 169, 195, 238, and 276.

Hitch Offset:

D1800



D2100

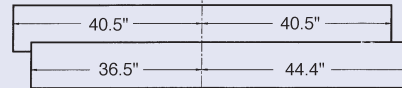

D2300

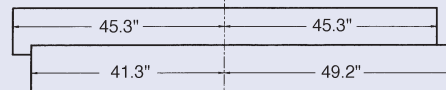

D2500



Gear Ratios

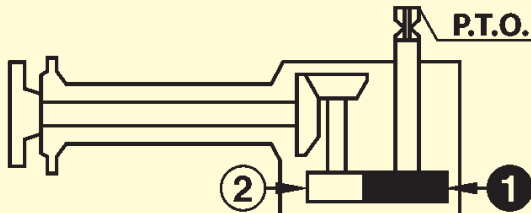

on request

	18	19	21	23	17	16
1						
2	23	21	19	18	28	25
rpm (540 pto)	169	195*	238	276	-	-
rpm (1000 pto)	313	361	-	-	242	255

Rear Rollers

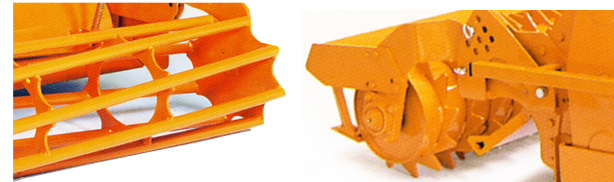

Tube Type Rear Cage Rollers:

80032	Tube type cage roller 62" fits 1600	271 lbs
80028	Tube type cage roller 72" fits 1800	282 lbs
80029	Tube type cage roller 80" fits 2100	293 lbs
80030	Tube type cage roller 90" fits 2300	304 lbs
80031	Tube type cage roller 100" fits 2500	315 lbs

18" Packer Type Cage Rollers:

80244	Tube type cage roller 62" fits 1600	513 lbs
80240	Tube type cage roller 72" fits 1800	579 lbs
80241	Tube type cage roller 80" fits 2100	623 lbs
80242	Tube type cage roller 90" fits 2300	667 lbs
80243	Tube type cage roller 100" fits 2500	711 lbs

Model	Till Width	Gearbox	Weight	No of Blades
D4-1600	62"	4 speed	1188 lbs	36
D4-1800	72"	4 speed	1298 lbs	42
D4-2100	80"	4 speed	1408 lbs	48
D4-2300	90"	4 speed	1540 lbs	54
D4-2500	100"	4 speed	1631 lbs	60

Options

81128	Pair- depth control wheels w/ mounting brackets	205 lbs	
--------------	---	---------	--

FALC ROTARY TILLERS

Model EL Rotary Tiller



- For 60 - 120 hp tractors
- 540 or 1000 rpm PTO
- 2 speed gearbox (1 only on 1000 rpm pto).
- Category II hitch
- Standard PTO with slip clutch.
- Spike-type rotor and straight-blade rotors available.

Gear Ratios								
on request								
1	27	29	24	32	22	34	21	35
2	29	27	32	24	34	22	35	21
rpm: 540 pto	208	240	168	298	-	345	-	373
rpm: 1000 pto	386	-	310	-	267	-	249	-

Model	Till Width	Wt (lbs)	Blades
EL2500	103"	1995	60
EL3000	123"	2260	72
Options			
81127	Pair- depth control wheels		
262173	EL3000 pair of trailing board extensions		
263019	EL3000 kit, front dirt shield		
Rear Rollers			
697079	Smooth roller; EL3000		
80033	Tube type cage roller 103". Fits EL2300		
80034	Tube type cage roller 123". Fits EL3000		

Model FL Rotary Tiller

- For 80 - 140 HP Tractors
- 1000 RPM PTO
- Gearbox with interchangeable gears.
- Gear side drive.
- Category II hitch
- PTO shaft with torque limiter
- Spike-type rotor and straight-blade rotors available.

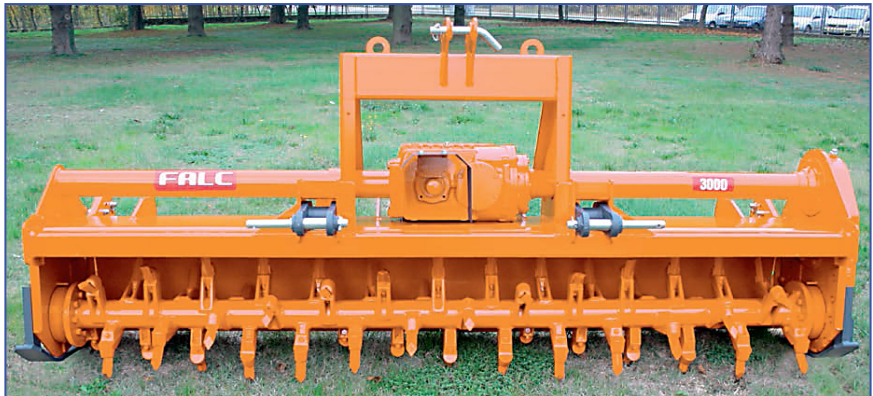

Gear Ratios				
on request				
1	24	27	26	21
2	37	34	35	40
rpm: 1000 pto	268	329	307-	217

Model	Till Width	Wt (lbs)	Blades
FL3000	123" working width	2646	72
Options			
81129	Depth control wheels (pr)	286	
81135	Pair- depth control skids		
Tube Type Rear Cage Rollers:			
80020	Tube type cage roller	462	
18" Packer Type Rollers:			
80225	Packer type roller	748	

TILLAGE

FALC ROTARY TILLERS

Model GL & GSL Tiller

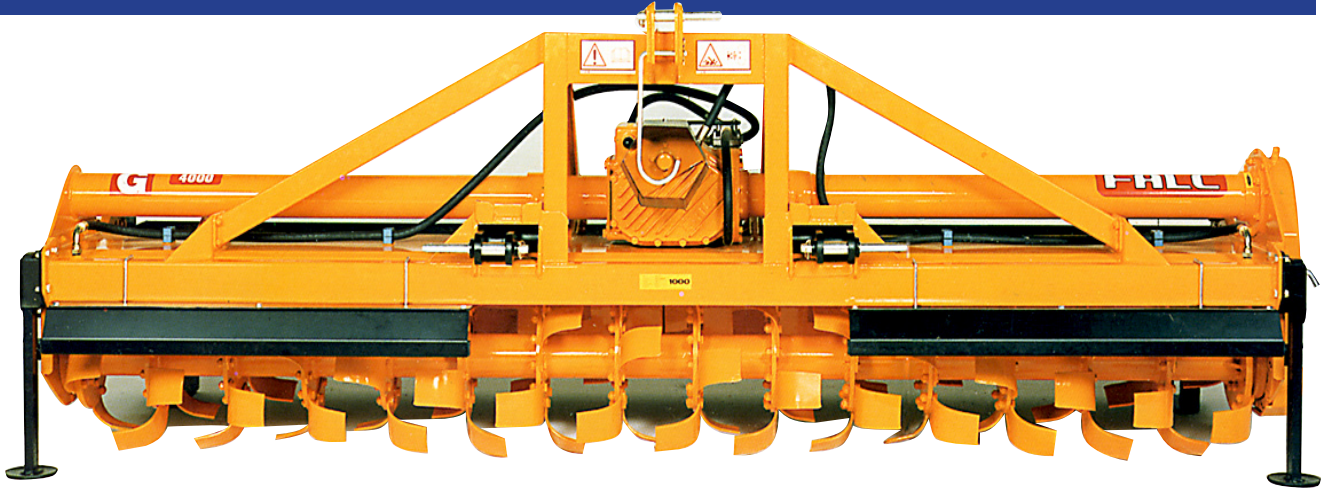

Standard Equipment:

- For 120 - 220 horsepower tractors.
- 1000 rpm pto w/ torque limiter
- Single speed gearbox. Alternate gear ratios available on request.
- Oil cooler std 4000-4500, optional on 3000-3500.
- Category II/III hitch

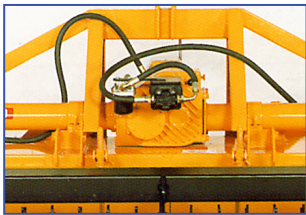

Oil Cooler

Oil cooler kit is standard on 4000 and 4500. Optional oil cooler kit available for 3000 and 3500.

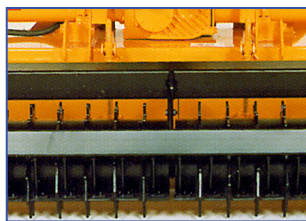

Rear Roller

Shown here is optional 18" packer roller. 22" packer roller and tube-type cage rollers are also available

Model	Description	Weight (lbs.)	No of Blades
GL3000	122" Rotary Tiller	3263	66
GL3500	142" Rotary Tiller	3715	78
GSL4000	162" Rotary Tiller	4277	90
GSL4500	182" Rotary Tiller	4674	102
Options			
81129	Pair- depth control wheels	286	
81135	Pair- depth control skids		
	Oil Cooler Kit for G2500/GL3500. Installed.		
Tube Type Rear Cage Rollers:			
80529	Tube cage roller 122"	462	
80530	Tube cage roller 142"	528	
80517	Tube cage roller 162"	836	
80518	Tube cage roller 182"	924	
18" Packer Type Cage Rollers:			
80229	18" Diameter packer roller 122"	748	
22" Packer Type Rollers:			
80734	22" Diameter packer roller 22"	1078	
80735	22" Diameter packer type roller 142"	1188	
80724	22" Diameter packer type roller 162"	1320	
80725	22" Diameter packer type roller 182"	1452	

Gear Ratios

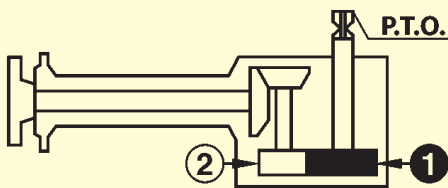

	Model GL				Model GSL		
1	27	30*	23*	21*	33	30*	27*
2	43	39*	46*	49*	36	39*	43*
rpm 1000 pto	290	355	307	217	248	248	203
*on request							

Spike type (Rotoking) & Straight blade type (Terraking) rotors Also available on Request. Call for info

FALC ROTARY TILLERS

Gamma Folding Tiller

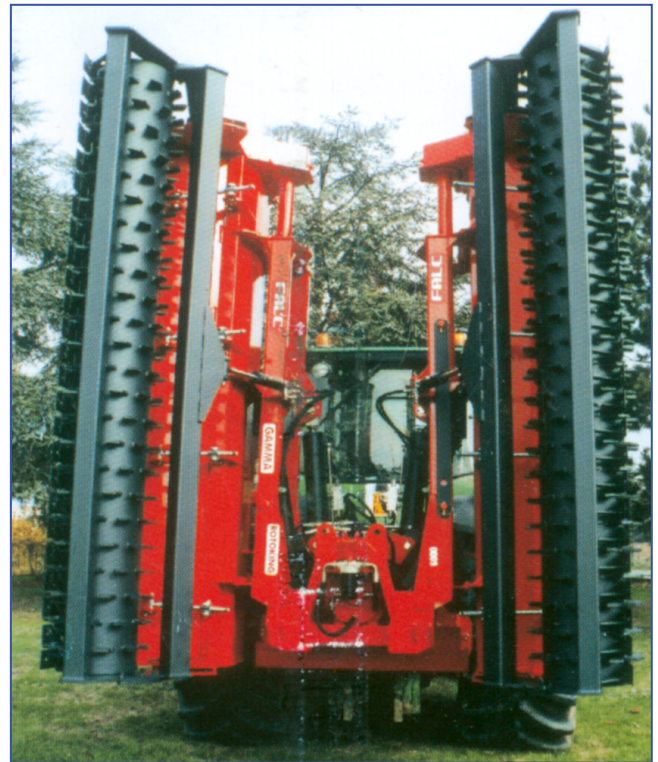

Standard Equipment:

- Rear trailing board extensions
- 380 HP rated, single speed gearbox with oil cooler
- Dual end drives
- 1000 rpm pto with torque limiter
- 330 rpm rotor
- Durafaced tiller blades; 6 blades per flange
- Quick hitch compatible Cat III hitch
- Also available with spike rotor.
- Double rotor flanges.

Model	Description	Wt (lbs)	Blades
Gamma 5000	Folding Tiller; 198" till width	9017	120
Gamma 6000	Folding Tiller; 237" till width	9899	144
Options			
80565	Tube type cage roller 212"		
80566	Tube type cage roller 252"		
80731	Packer roller 212"		
80732	Packer roller 252"		

TILLAGE

FALC ROTARY TILLERS

Kappa Tiller



Dual rotor Kappa 6000, equipped with optional Rotoking spike rotor

- For use with 190-300 hp Tractors
- 1000 rpm PTO with torque limiter
- 3-speed lever control gearbox. Rotor speeds - 246, 308, and 356 rpm.
- Cat III hitch & rear PTO
- Optional equipment includes depth control wheels, depth control skids, cage roller, and packer roller
- Spike-type rotor and straight-blade rotors available.
- Double wall rotor tube on 4000 & 4500.

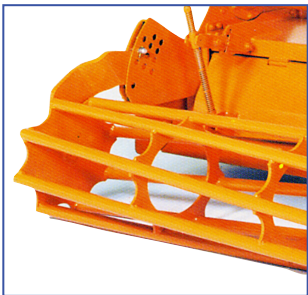

Cage Roller

Optional tube-type cage roller. Packer-type roller is also available.



Gearbox

3-speed lever control gearbox for 1000 rpm pto. Oil cooler standard.

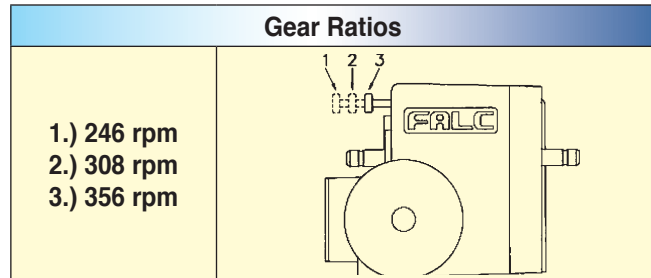

Gear Side Drive

Low maintenance gear side drive. Kappa 6000 features dual drive.



Three-Point

Category III Three point hitch is standard equipment.

Model	Description	Wt (lbs)
Kappa 4000	Rotary Tiller; 162" till width	5798
Kappa 4500	Rotary Tiller; 182" till width	6547
Kappa 6000 DT/2	Rotary Tiller; 250" till width	7760

Options	
81129	Rubber depth wheels
80517	Tube type cage roller 162"
80518	Tube type cage roller 182"
80520	Tube type cage roller 250"
80724	22" diameter packer roller 162"
80725	22" diameter packer roller 182"
80727	22" diameter packer roller 250"

Spike type (Rotoking) & Straight blade type (Terraking) rotors Also available on Request. Call for info

MASSANO TILLER BEDSHAPERS

RSF Tiller/Bedshaper



- The soil carrying stones or vegetable debris strikes a vertical “comb” of spring steel tines where loose clean soil passes through while stones, root clumps, clods, etc. are screened out falling to the bottom of cut to be buried by clean soil.
- Reverse rotating tiller that works soil and throws dirt up over the tillers rotor to the rear.
- 3 x 80 inch width
- For 200-260 HP tractor

Tiller/Bedshaper

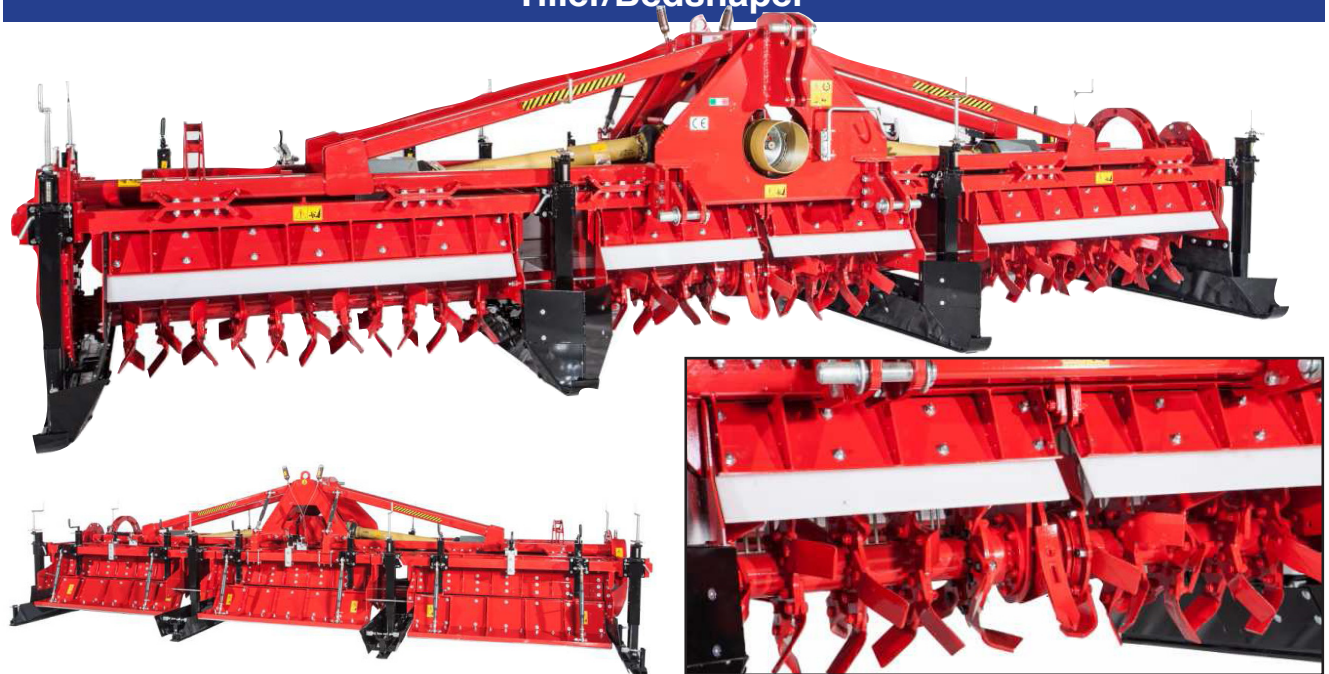

- The soil carrying stones or vegetable debris strikes a vertical “comb” of spring steel tines where loose clean soil passes through while stones, root clumps, clods, etc. are screened out falling to the bottom of cut to be buried by clean soil.
- Reverse rotating tiller that works soil and throws dirt up over the tillers rotor to the rear.
- 80 inch width
- For 80-150 HP tractor

PEPIN HARROW

Heavy Duty “FB” Series Flexible Reversible Harrow

For trashy fields, pulverizing, cultivating, breaking up clods and destroying early weeds. Flexibility allows the individual tooth bars to pass over obstructions while the other bars stay on the ground. When drawn from the front, the teeth are vertical for cultivating and penetrating deep into the soil. When drawn from the rear, the tooth angle is preset for self cleaning and smoothing.

1 5/8” O.D. High carbon heavy duty pipe for greater strength at high speed tractor operation and cultivating.

Connecting Links: 9/16” Specially welded for strength and less wear.

Drawhooks: 9/16” hooks open toward ground to stop unhooking during use.

Teeth: High carbon, hammer-forged to a diamond point, for hard use in all soil types. Cultivate, pulverize, smooth and break up crust and clods. Reversible and replaceable, teeth are locked on with a lock washer and nut.

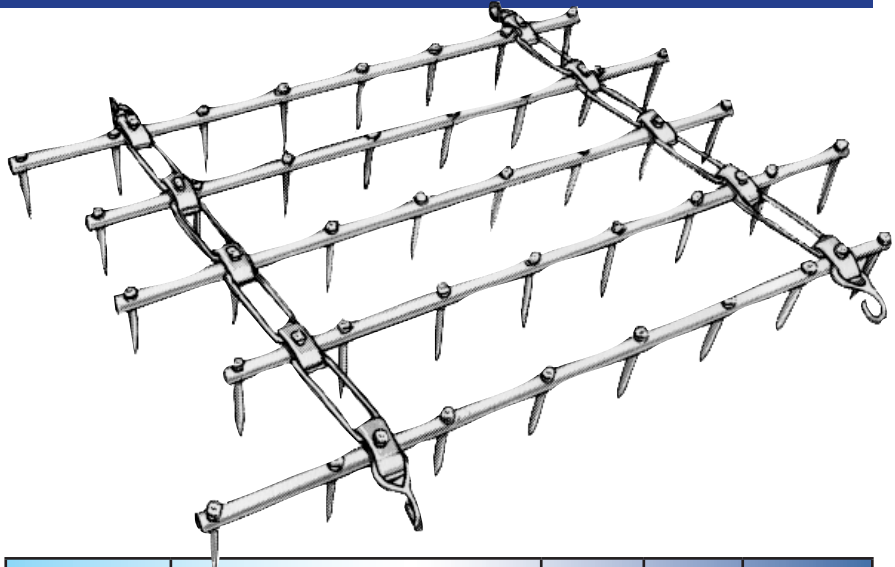

Model	Description	No. of Teeth	Width	Weight
FB-5	Flexible-reversible harrow	40	5'	98 lbs.
FB-55-1/2	Flexible-reversible harrow	40	5-1/2'	100 lbs.
FB-645	Flexible-reversible harrow	45	6'	106 lbs.
FB-6-1/2	Flexible-reversible harrow	45	6-1/2'	111 lbs.
FB-7	Flexible-reversible harrow	50	7'	121 lbs.
FB-8	Flexible-reversible harrow	60	8'	138 lbs.

Heavy Duty “OE” Series Flexible Pipe Bar Lever Harrow

Breaks up clods and crusts, pulverizes, smooths and cultivates; breaking up early weeds before they start to grow. Flexibility of the section permits it to pass over trash or rocks.

The exclusive lever design permits setting the teeth at any angle, yet allowing full flexibility in any position.

Tooth Bars: 1 5/8” O.D. High carbon steel pipe is extra strong and resistant to wear, for high speed harrowing.

Connecting Links: 9/16” Welded links for extra strength.

Teeth: High carbon, hammer-forged to a diamond point, for hard use in all soil types. Cultivate, pulverize, smooth and break up crust and clods. Reversible and replaceable, teeth are locked on with a lock washer and nut.

Drawhooks: 9/16” hooks open toward ground to stop unhooking during use.

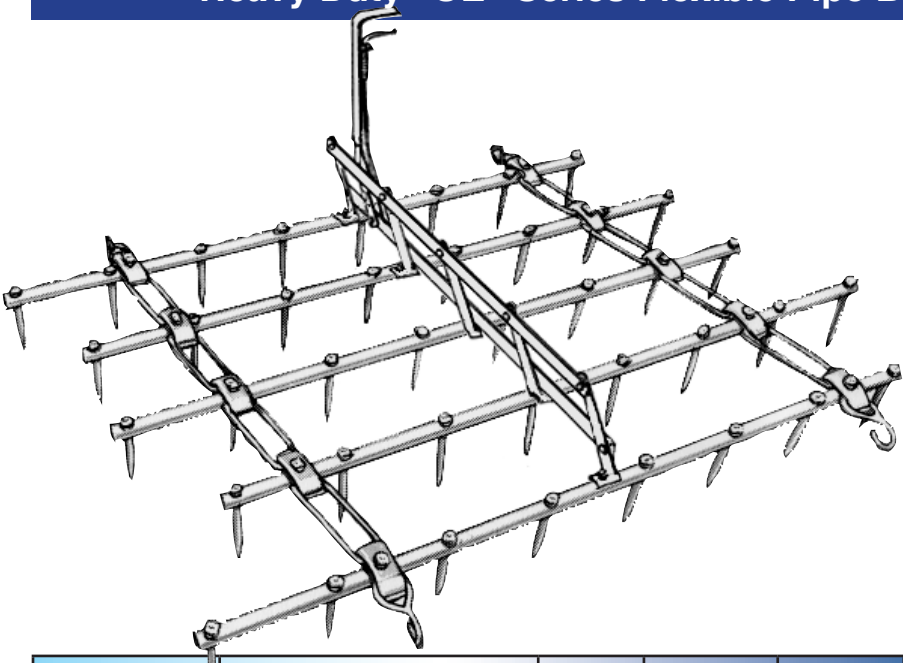

Model	Description	No. of Teeth	Width	Weight
OE-55-1/2	Flexible lever harrow	40	5-1/2'	118 lbs.
OE-645	Flexible lever harrow	45	6'	122 lbs.
OE-6-1/2	Flexible lever harrow	45	6-1/2'	129 lbs.
OE-7	Flexible lever harrow	50	7'	137 lbs.

TILLAGE

PEPIN HARROW

PB Series Heavy Duty Flexible/Rigid Pipe Bar Lever Harrow

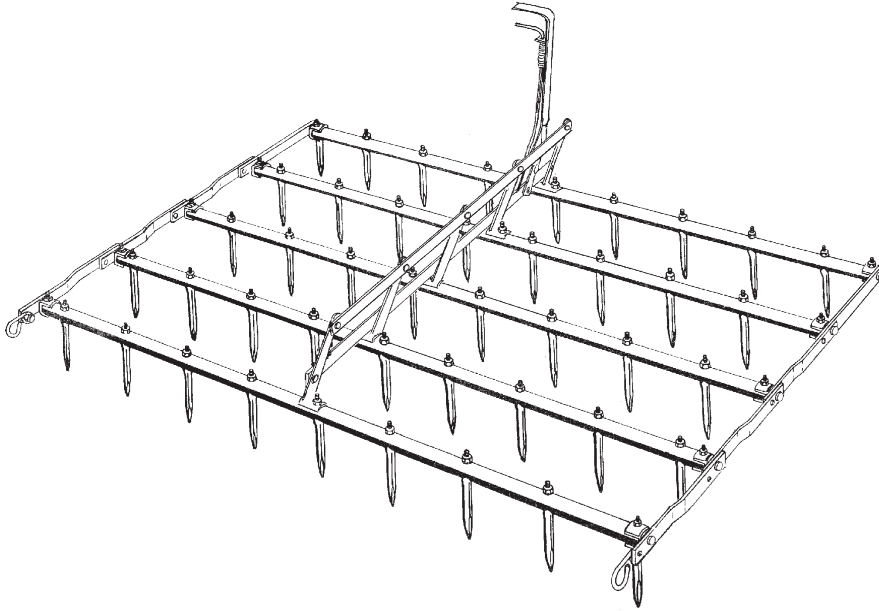

PB series is a flexible or rigid harrow: two for the price of one. To make the harrow section rigid, simply insert six bolts (5/16" x 3/4") into holes in the side rails. The flexible harrow is designed to let more trash through, while the rigid harrow is better suited for leveling.

Lever Assembly: Exclusive lever design permits setting the teeth to the angle best suited to specific soil and crop conditions, while allowing full flexibility in any position. The lever folds flat for transport.

Tooth Bars: 1-5/8" O.D. High carbon heavy duty pipe for greater strength.

Drawhooks: 9/16" hooks open toward ground to stop unhooking during use.

Teeth: High carbon, hammer-forged to a diamond point, for hard use in all soil types. Cultivate, pulverize, smooth and break up crust and clods. Reversible and replaceable, teeth are locked on with a lock washer and nut.

Model	Description	No. of Teeth	Width	Weight
PB-55A	Flexible/rigid lever harrow	40	5'	107 lbs.
PB-5-1/2	Flexible/rigid lever harrow	40	5.5'	114 lbs.
PB-6	Flexible/rigid lever harrow	43	6'	120 lbs.
PB-7	Flexible/rigid lever harrow	55	7'	138 lbs.

DS Series Heavy Duty Rigid Pipe Bar Lever Harrow

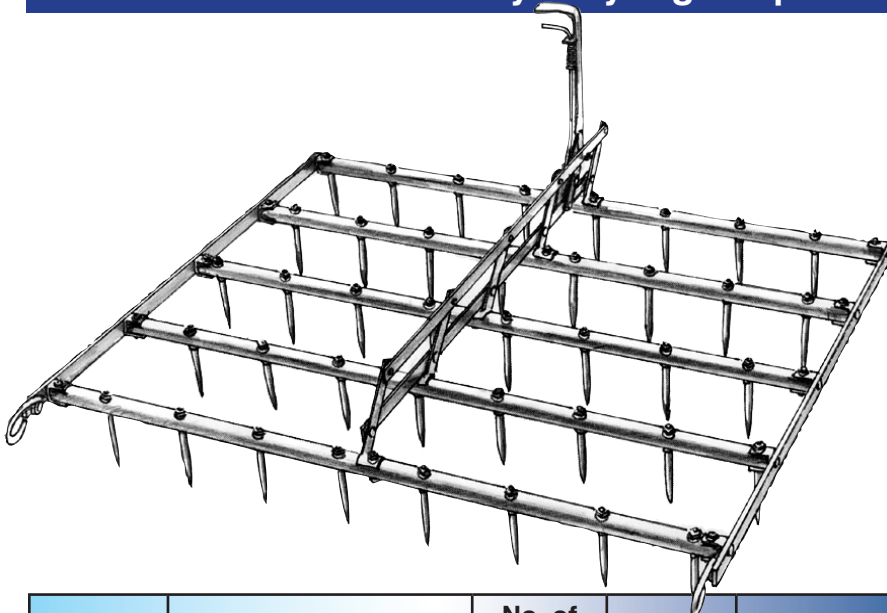

Cultivates and levels the ground better because of its design and rigidity. Side rails and lever assembly are made of high carbon material for extra rigidity.

Tooth Bars: 1 5/8" O.D. High carbon heavy duty pipe for greater strength at high speed tractor operation.

Drawhooks: 9/16" hooks open toward ground to stop unhooking during use.

Teeth: High carbon, hammer-forged to a diamond hard point, for hard use in all soil conditions to cultivate, pulverize, smooth and break up crust and clods. Each tooth is reversible and replaceable. Teeth are locked on with a lock washer and nut, and are guaranteed to outlast any other tooth of equal weight.

Lever Assembly: Tilts the teeth to the angle best suited to soil and crop conditions. The lever folds down flat for easy in handling and storage.

Model	Description	No. of Teeth	Width	Weight
DS-42	Rigid lever harrow	40	5'	109 lbs.
DS-43	Rigid lever harrow	43	5.5'	114 lbs.
DS-47	Rigid lever harrow	47	6'	120 lbs.
DS-51	Rigid lever harrow	51	6.5'	127 lbs.
DS-55	Rigid lever harrow	55	7'	137 lbs.

TILLAGE

PEPIN HARROW

Heavy Duty “R” Series Rigid Open End Lever Harrow

“R” Series harrows are designed for high speed harrowing and cultivating. Durable tooth bars are braced four ways to stay in position. Double adjustable bars add strength.

Lever Assembly: Tilts the teeth to the angle best suited to soil and crop conditions. The lever folds down flat for ease in handling and storage.

Tooth Bars: 1 5/8” O.D. High carbon steel pipe for extra strength and resistance to wear. Each bar is held firmly in position to assure every tooth is working the soil thoroughly.

Drawhooks: 9/16” hooks are designed with the open end toward the ground to reduce unhooking.

Teeth: High carbon, hammer-forged to a diamond point, for hard use in all soil types. Cultivate, pulverize, smooth and break up crust and clods. Reversible and replaceable, teeth are locked on with a lock washer and nut.



Model	Description	No. of Teeth	Width	Weight
R-550	Rigid heavy-duty lever harrow	40	5.5'	177 lbs.
R-600	Rigid heavy-duty lever harrow	40	6'	183 lbs.
R-700	Rigid heavy-duty lever harrow	50	7'	207 lbs.

SQB Series Square Bar Lever Harrow



Tooth Bars

2” Square high carbon, heavy wall tube for superior leveling action.

Lever Assembly

High carbon double expanding bar for more strength.

Draw Hooks

Pivoting draw hooks set up for even pulling and better leveling (keeps the front bar down).

Teeth

High carbon hammer forged, diamond hard REPLACABLE teeth pulverize and break up clods.

Side Rails

3/8” thick, High carbon with unique off-set configuration to leave no ridges between harrow sections.

Model	Description	No. of Teeth	Width	Weight
SQB-5	Square bar lever harrow	39	5'	145 lbs.
SQB-6	Square bar lever harrow	45	6'	162 lbs.
SQB-7	Square bar lever harrow	55	7'	179 lbs.

PEPIN HARROWS

Straight And Folding Drawbars

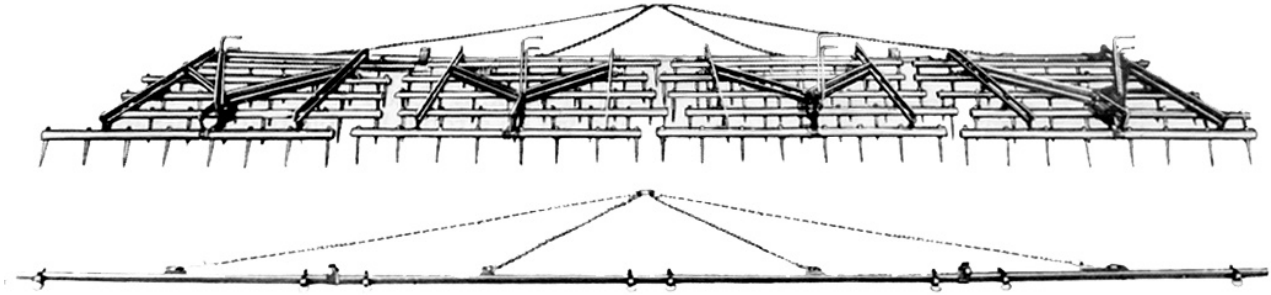

Pictured: (at top) 21-4 CPT drawbar with Four R-55-1/2 harrow sections. (above) Chain type double hinge drawbar

These combination folding or trailing drawbars with chain type hitches are the most versatile units you can buy. Here's why you get more performance per dollar when you buy a Pepin high speed drawbar:

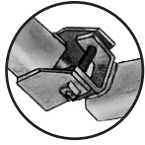

Combination hinge: Drawbar may be easily folded. Or, if you prefer, section may be trailed by removing one bolt to detach drawbar end.



Adjustable take-up: Durable coil change will never stretch or tangle. All chains may be adjusted for equal tension under all conditions.



Section Clevis: The clevis locks securely in any position of the drawbar. Fits all section widths.

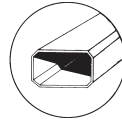

Tubular bar: 1-1/2" x 2-1/2" bar is made from high carbon steel and features rounded corners.

Fits Sections	Harrow Description	Part Number	Length	No. of Sections	Weight
PB-55A DS-42 FB-55 FB-55-1/2 OE-55-1/2	For 5' closed or 5-1/2' open end harrow sections	**80-TC	10' 6"	2	35 lbs.
		**3-SC	15' 6"	3	57 lbs.
		163-C	15' 9"	3	57 lbs.
		214-C	21' 0"	4	85 lbs.
		265-C	26' 3"	5	116 lbs.
PB-5-1/2 DS-43 FB-645 OE-645	For 5-1/2' closed or 6' open end harrow sections	**86-TC	11' 6"	2	38 lbs.
		173-C	17' 3"	3	62 lbs.
		234-C	23' 0"	4	92 lbs.
		285-C	28' 9"	5	125 lbs.
PB-6 DS-47 FB-6-1/2 OE-6-1/2	For 6' closed or 6-1/2' open end harrow sections	**94-TC	12' 6"	2	40 lbs.
		183-C	18' 9"	3	68 lbs.
		254-C	25' 0"	4	99 lbs.
		315-C	31' 3"	5	137 lbs.
PB-6-1/2 DS-51 FB-7 OE-7 *R-700	For 6-1/2' closed or 7' open end harrow sections	**102-TC	13' 6"	2	45 lbs.
		193-C	20' 3"	3	75 lbs.
		274-C	27' 3"	4	107 lbs.
PB-7 DS-55	For 7' closed end harrow sections	**110-TC	14' 6"	2	53 lbs.
		213-C	21' 9"	3	85 lbs.
		294-C	29' 0"	4	124 lbs.

*Recommend wheel type drawbars on 5 section **Straight Drawbar only

ROBOCROP SELF-GUIDED WEEDER

Robocrop Camera-Guided Cultivator

Robocrop is the original crop imaging system which achieves excellent row following by viewing multiple crop rows over a large area. The robocrop provides accurate row following even on narrow and multi line rows.

Images are analyzed at a rate of 30 frames per second and the direction of the cultivator is adjusted via a hydraulic sideshift with anti backlash action. Accuracy is generally 15mm at the camera or, with the addition of soil engaging discs better than 10mm accuracy is possible.

Speeds of up to 12kph are common and higher speeds have been successfully employed. Fortunately, Robocrop hoes are adapted to cope with these extreme speeds. Special pressure rams keep the soil engaging components working and improve hard soil penetration. Garford blades ensure no “slip by” of weeds adjacent to the row and provide good foliage clearance to prevent stripping.



Robocrop In-Row Weeder and Thinner



The Robocrop guidance system uses a digital video camera to analyze to find the position of the individual plants. This information is then utilized for lateral steering of the hoe and individual synchronization of the In-Row Weeder disc. Robocrop is programmed to constantly adjust the rotational speed of disc to suit the variability of plant spacing.

Inter-row and InRow Implement: Row following is maintained accurately within 10mm of detected plant foliage. Working depth is controlled via the parallel linkage wheel.

Mechanical Design: The In-Row Weeder system uses a special shaped disc rotating about an axis and set to cultivate at a shallow depth (typically 10 to 20mm) within the crop row. The crescent shaped disc arcs around the plants and then cuts in between the plants as it rotates around the axis.

The disc is coupled directly to a hydraulic motor which is driven via a proportional hydraulic valve controlled by the Robocrop computer.

Performance: A performance of up to 3 plants per second per row is achievable.

Farmers that use the Robocrop InRow Weeder have told us that they save ~\$100 per acre. That's money you're losing every year you're not using a Robocrop Weeder.

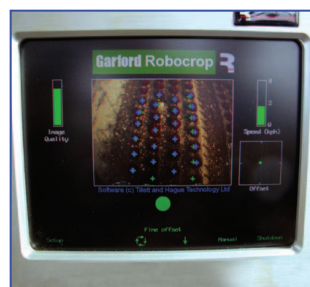

CHECCHI & MAGLI TRANSPLANTERS

Plastic Stop Mulch Layer

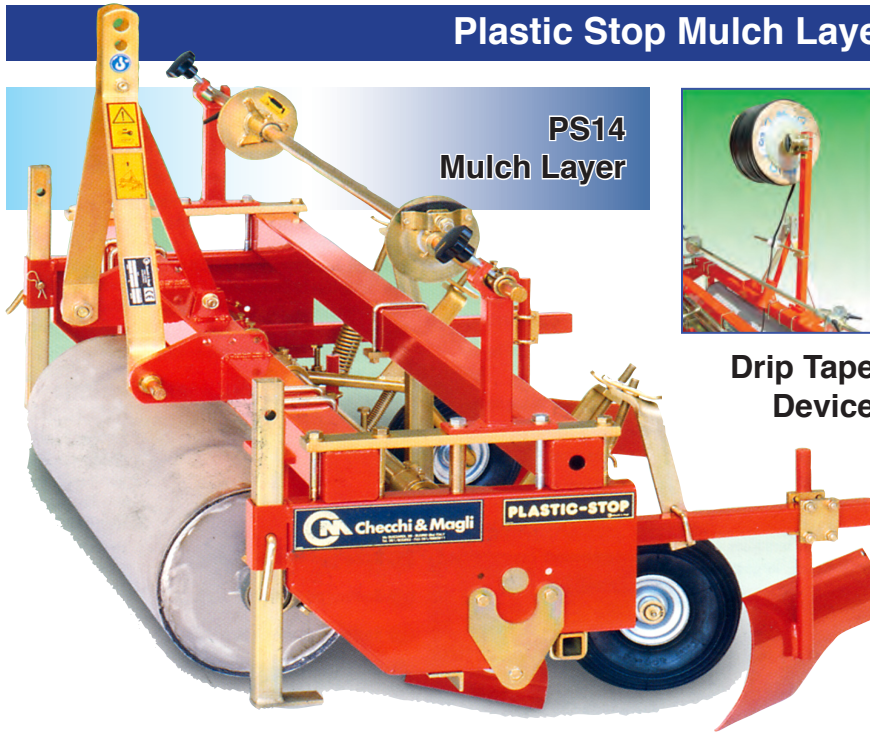

PS14
Mulch Layer



Drip Tape
Device



- 55" and 75" available widths.
- Stainless rear roller with adjustable roller width.
- Available front mounted rubber tire gauge wheels.
- Available bed maker allows you to simultaneously form bed and lay plastic mulch. Bed height from 4" to 12" and bed top from 18" to 34".
- 25 hp power requirement.

Model	Description	Wt
PS14S	Plastic Mulch Layer with stainless roller, for plastic up to 55" wide	583 lbs
PS14R	Plastic Mulch Layer, with rubber wheels, for plastic up to 55" wide	583 lbs
PS19S	Plastic Mulch Layer, stainless roller, for plastic up to 75" wide	693 lbs
PS19R	Plastic Mulch Layer, with rubber wheels, for plastic up to 75" wide	693 lbs

Foxdrive Transplanter

The Foxdrive pocket planter handles bare roots, cuttings, and plugged plants. The plated roller chain provides smooth operation and uniform plant spacing.

The Foxdrive planter is especially desired when planting bare root plants or when the plants are of different heights, but all plants are to be the same distance above ground.



Optional Parallel Linkage

Ensures horizontal attitude of transplanter chassis over uneven surfaces.



TRANSPLANT

CHECCHI & MAGLI TRANSPLANTERS

Dual 12 Gold Transplanter

The Checchi & Magli Dual 12 is a top-quality rotary transplanter that allows a single operator to do the job of two. With a Dual 12, you can transplant two lines from just one row of transplanter. The staggered spacing between the two lines is adjustable from 12" to 20" and within each row, plant spacing is adjustable from 5.5" to 20" using the multi-sprocket drive wheel.

The Dual 12 Gold will accept plants rooted in conical or pyramidal shaped plugs. It is available with your choice of rotary or sloped tray holder. An automatic safety disengagement helps to prevent operator injury.



Recommended Usage:

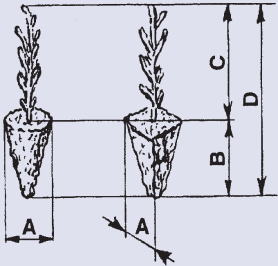

- A = 1/2" to 1-1/2"
- B = 1-1/2" to 2-3/4"
- C = 3" to 8"
- D = 4-3/4" to 10-1/2"

Distributor

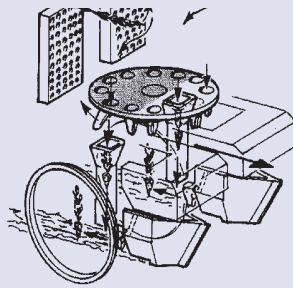

Horizontal rotating with 12 bottom-opening cups with staggered-row plant distribution.

Chassis

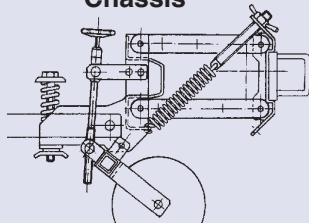

Independent floating row units. Parallel linkage chassis stays horizontal. Adjustable spring for packing wheel pressure. Cross-joint system allows independent floating of each plant line.

Plant Spacing (cm)

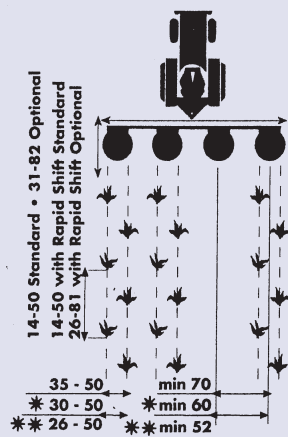

Accessories



Part No.	Description
500428	Distributor Cup Extensions (set of 12)
510111	Kit to add 2nd seat to row unit
510096	Pair coulters to mount in front of runners
500032	Rotary tray holder
510099	Skid kit (pair)
510063	Spacing kit (3.9")
550041	Spacing kit (12.2" - 32.3")
500207	Transverse tray holder 2.0 m
500209	Transverse tray holder 2.5 m
500209	Transverse tray holder 3.0 m
500214	Transverse tray holder 3.5 m
500410	Transverse tray holder 4.0 m
500385	Water Valve (per line))

CHECCHI & MAGLI TRANSPLANTERS

Wolf Transplanter

The Wolf Transplanter is specially designed so it can plant in soil prepared with plastic mulch. Its rotating perforating cups smoothly pierce soil with or without plastic mulch and gently deposit young plants.

The Wolf will handle a wide range vegetables, flowers, nursery plants, and bulbs up to 2-3/8" across and up to 8-1/2" in height

Spacing is determined by a combination of the number of cups used and choice of ground drive sprockets. This allows enormous flexibility in plant spacing ranging from 7.9" to 76". Planting depth is adjusted by simply turning a handcrank. Wear parts are cadmium-plated for long life.



Wolf Compact

Exactly the same as the Wolf, but with a distance between rows that can reach a minimum of 12"

This close inter-row distance makes it particularly suitable for transplanting 3 or 4 rows of salad on mulching film.

Recommended Usage:

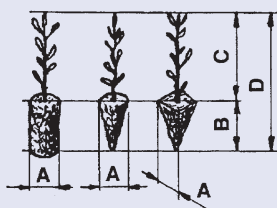

Conical or cylindrical with dia up to 6 cm

Cubic, from 3x3 to 4x4 cm with optional insert

Cubic, from 5x5 to 6x6 cm with optional. 6x6 cups

Bare root plants w/ suitable leaf system. bulbs & seeds up to 6cm

Plant Spacing:

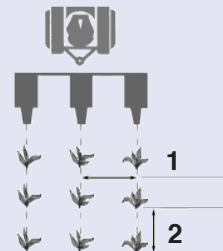

1 Row spacing

Wolf :
2 row: 12.5" - 35.5"
3-6 row: 19.75"-35.5"
Wolf Compact:
3-8 row: 12 - 20"

2 Spacing in-row

All: 7.9" to 76"

Accessories



Increases operator speed from 83 to 100 plants/minute.



For higher capacity than standard rotary tray holders

Part No.	Description
500279	Brush Kit
500006	Deep cups (will not accept 6 cups)
500405	Fast Wolf device
500280	Film Slide Wolf
500032	Rotary Tray Holder
500579	Transverse tray holder 1.5 m
500207	Transverse tray holder 2.0 m
500208	Transverse tray holder 2.5 m
500209	Transverse tray holder 3.0 m
500214	Transverse tray holder 3.5 m
500410	Transverse tray holder 4.0 m
500282	Water Valve

Mod.	1 cup	2 cup	3 cup	4 cup	5 cup	6 cup
	In-row plant spacing					
Wolf	48-78"	24-39"	16-26"	12-20"	10-15"	8-13"

CHECCHI & MAGLI TRANSPLANTERS

Wolf B24/B27/B30/B40 Transplanters

The B24 B27, B30, & B40 are the same as the same as the Wolf, except that they plant two lines staggered on 24 cm (9.5"), 27 cm (10.6"), 30cm (11.8"), or 40cm (15.8") centers. This is ideal for crops that are planted two lines per bed.

Spacing is determined by a combination of number of cups and sprockets used on ground drive wheel. Planting depth is adjusted by turning a handcrank.

Standard equipment includes: rows of planter, toolbar with hitch, ground drive wheel and support wheels, plastic seats and

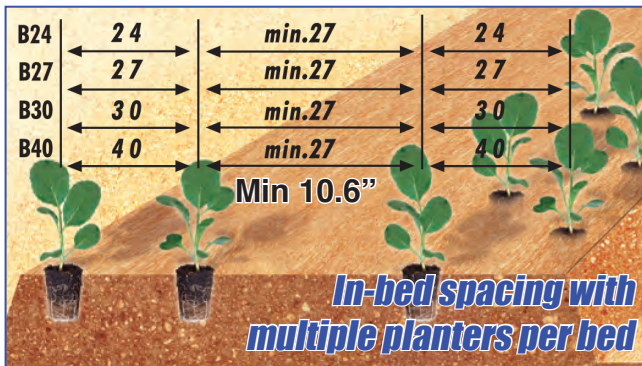
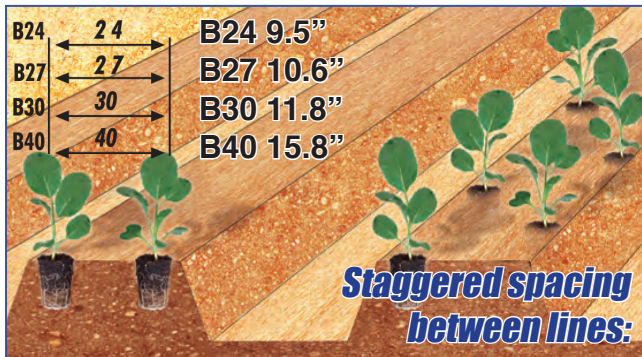
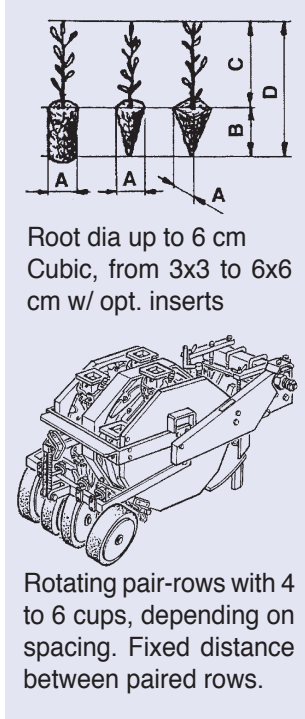

Accessories



Increases operator capacity 17% from 83 to 100 plants per minute.

For those who need higher capacity than the standard rotary tray holders

Model	Distance in between lines	D4	D5	D6
		(4 cup)	(5 cup)	(6 cup)
In-row Plant Spacings				
B24	9.5"	12 - 20"	10 - 15"	8 - 13"
B27	10.6"	12 - 20"	10 - 15"	8 - 13"
B30	11.8"	12 - 20"	10 - 15"	8 - 13"
B40	15.8"	12 - 20"	10 - 15"	8 - 13"

Part No.	Description
500279	Brush Kit
500006	Deep cups (will not accept 6 cups)
500411	Fast Wolf Device B24
500412	Fast Wolf Device B27
550007	Fast Wolf Device B30
500399	Fast Wolf Device B24
500672	Fast Wolf Device B27
500673	Fast Wolf Device B30
500032	Rotary Tray Holder
500579	Transverse tray holder 1.5 m
500207	Transverse tray holder 2.0 m
500208	Transverse tray holder 2.5 m
500209	Transverse tray holder 3.0 m
500214	Transverse tray holder 3.5 m
500410	Transverse tray holder 4.0 m
500282	Water Valve

CHECCHI & MAGLI TRANSPLANTERS

Trium Transplanter



**Trium
2 Row
Transplanter**

Trium is a 10 cup rotary transplanter that will accommodate large, bushy plants. Plant spacing is adjustable from 5.5" to 20" by simply changing a ground drive sprocket. Depth and position of rear press wheels are controlled with the turn of a knob. The Trium may be mounted on 22" centers

The Trium will accept plants rooted in conical or pyramidal shaped plugs.

A latch releases the planter shoe to remove unwanted soil. Available with rotary tray or sloped tray holders.

Unitrium

Same planter as the Trium with large front drive wheel instead of ground drive. Plant Spacing 3.9" to 39.4"



Recommended Usage

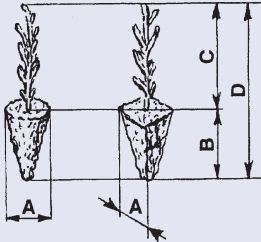

- A = 1/2" to 3"
- B = 1-1/2" to 2-3/4"
- C = 3" to 9"
- D = 4-3/4" to 12"

Chassis

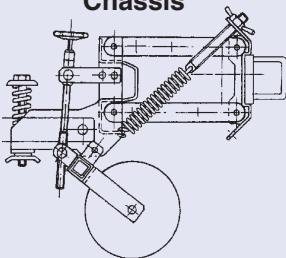

Independent floating row units. Parallel linkage chassis stays horizontal. Adjustable spring for packing wheel pressure. Front flex wheels.

Distributor

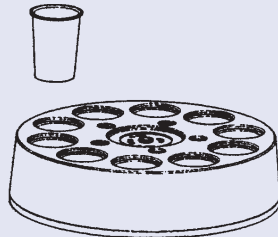

Horizontal rotating carousel with 10 cups with standard distributor extension.

Plant Spacing

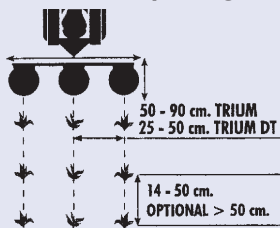

Row spacing:

Trium: 19.75" - 35.5"
Trium DT: 10" - 35.5"

Plant spacing in row:

All: 5.5" to 19.7"
Optional: >19.7"

Accessories



Coupler Kit



Rubber Wheels



Skids



Transverse Trays

Model	Description	Weight
Trium 1	One row planter 1.5 m bar	435 lbs
Trium 2	Two row planter 2.0 m bar	698 lbs
Trium 3	Three row planter 3.0 m bar	1027 lbs
Trium 4	Four row planter 3.5 m bar	1296 lbs
Trium 6	Six row planter 4.0 m bar	1835 lbs
Trium 8	Eight row planter 4.5 m bar	2390 lbs

Part No.	Description
510063	Close Spacing Kit - 10 cm (per drive wheel)
550045	Extend spacing Kit
510104	Front Coupler Kit
510093	Cup reducers (set of 10) for small Plants
500032	Rotary Tray Holder
510085	Runner, narrow 8 mm (standard)
510128	Runner 18 mm
510126	Runner 33 mm
510055	Runner 42 mm
550003	Rubber press wheels add per row
510094	Skid assembly
500207	Transverse tray holder 2.0 m
500208	Transverse tray holder 2.5 m
500209	Transverse tray holder 3.0 m
500214	Transverse tray holder 3.5 m
500410	Transverse tray holder 4.0 m
500413	Water Valve

CHECCHI & MAGLI TRANSPLANTERS

Baby Trium

The Baby Trium is the same design as the Trium. The Baby Trium has 6 cups vs 10 cups on the Trium. This planter can be mounted on 19.7" centers, the same as the Trium.

The Baby Trium is 59" long vs 79" on the Trium.



Baby Compact



Basically the same as the Trium and Baby Trium except it has 8 smaller diameter cups and can be mounted on as close as 11" centers.

Suitable for plantings of five or six lines on a single bed.

Standard plant spacing 5.5" to 19.7" with farther spacings optional. Skids are standard equipment

CHECCHI & MAGLI TRANSPLANTERS

F300L Potato Planter

The F300L is a high quality potato planter that will save you field time with its high working speed. The Checchi & Magli potato planter also provides unmatched precision and ease of use.

The F300L planter will handle whole or cut potatoes and bulbs. Plant spacing ranges from 5.5 to 11 inches, simply by choosing gears for the smooth-running drive system. Spacings over 11 inches on request. Planting depth is also easily adjustable.

All models mount to A-frame toolbar and require a minimum of 20-40 hp.



SP50V & SP100 Potato, Bulb, and Tuber Digger



SP50
Rear Discharge

The SP50V rear discharge digger has a vibrating plow share to assist in soil penetration. The vibrating sieve eliminates sandy soil from the tubers. Designed for tractors with narrow track of 25.5 to 40". Offset mount optional.



SP100
Side Discharge

The SP100 side discharge digger has a fixed plow share and double vibrating sieves to eliminate heavier soils from tubers. Designed for tractors with track of 47" to 60". Offset mount optional.

HOLLAND TRANSPLANTER

Model 1500 Pocket Transplanter

- Mounts on 40" centers or greater.
- Closing guides, foot rests, plant boxes.
- Welded steel frame.
- Adjustable steel chain tighteners.
- Heavy-duty drive wheels and sprockets.
- Grease fittings.
- Can be mounted on 2-1/2" diamond bar, 4x4 or 4x7 bars.

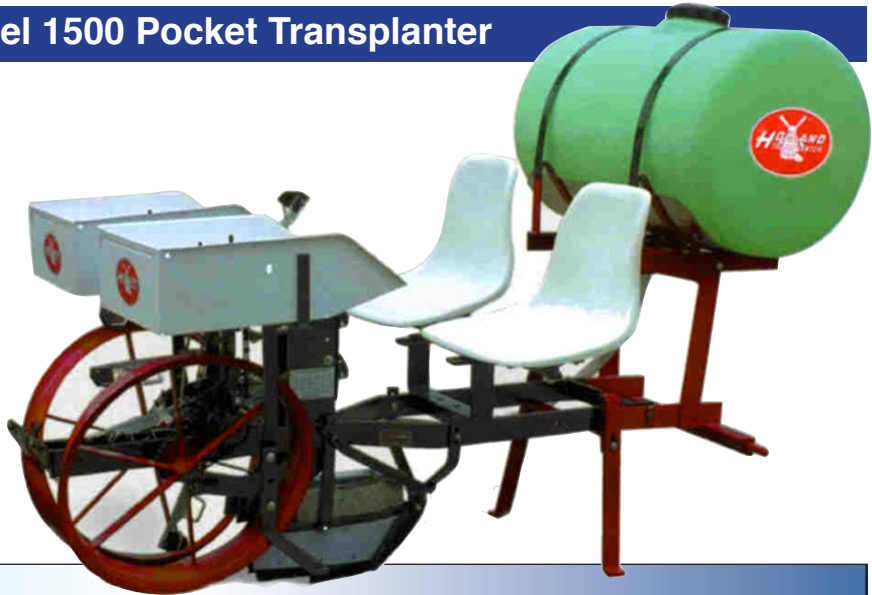

Part No	Description
	Row of 1500 Transplanter requires seats and hitch to complete. 6, 8, 10, or 12 pockets on chain drive arrangement 8, 10, 12, 16, or 20 pockets on disc drive arrangement.
Options	
39501	Steel pan seats (pair)
39509	Steel back rests (pair)
39502	Fiberglass molded seats (pair)
39503	Padded seats (pair)
39562	Rubber packing wheels (pair)

Model 1600 Pocket Transplanter

- Mounts on 40" centers or greater.
- Closing guides, foot rests, plant boxes.
- Welded steel frame.
- Adjustable steel chain tighteners.
- Heavy-duty drive wheels and sprockets.
- Grease fittings.
- Can be mounted on 2-1/2" diamond bar, 4x4 or 4x7 bars.

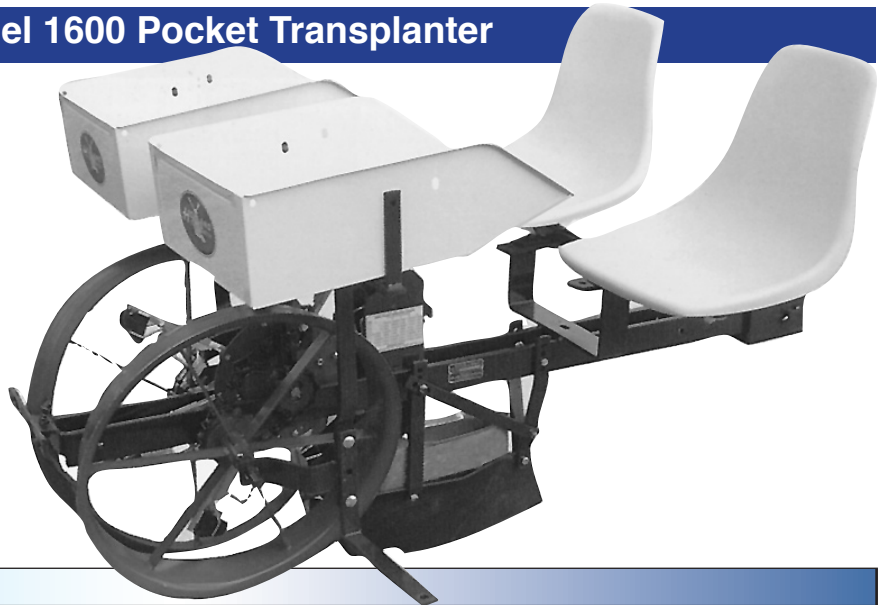

Part No	Description
	Row of 1600 Transplanter requires seats and hitch to complete. 6, 8, 10, or 12 pockets on chain drive arrangement 8, 10, 12, 16, or 20 pockets on disc drive arrangement.
Options	
39501	Steel pan seats (pair)
39509	Steel back rests (pair)
39502	Fiberglass molded seats (pair)
39503	Padded seats (pair)
39562	Rubber packing wheels (pair)

HOLLAND TRANSPLANTER

Model 1265 Mulch Transplanter



Standard Equipment: Spades, 2 plant trays, 2 fiberglass seats, G70/15 drive tire, support wheel, rubber packing wheels with weight bracket, parking stand.

Cat I or Cat II hitch required to complete.

- Designed to plant through the laid plastic mulch.
- Specially designed heavy duty spades in 8 different sizes to fit different sized plugs.
- Welded tubular frame for added strength.
- Parking stand.
- Water valve feeds each plug at time of transplanting.
- Fully adjustable packing wheels, with weight basket.

Part No	Description
1265-1	One spade planter 84" plant spacing
1265-2	One spade planter 42" plant spacing
1265-3	One spade planter 28" plant spacing
1265-4	One spade planter 21" plant spacing
1265-5	One spade planter 17" plant spacing
1265-6	One spade planter 14" plant spacing
1265-7	One spade planter 12" plant spacing
1265-8	One spade planter 10-1/2" plant spacing
Spade options	
M10S	3/4" round or square for 1265-8 only
M10	3/4" round or square
M10A	1 to 1-1/2" round or square
M11	1-1/2" to 2" round
M12	1-1/2" to 2" square
M13	2 to 2-3/4" square
M14	2 to 2-3/4" round
M15*	3" -- Cannot use on 1265-7 or 1265-8
M16*	4" -- Cannot use on 1265-7 or 1265-8

Model 1275 Mulch Layer

- Can lay up to 70" wide plastic mulch without tearing, on flat ground or beds.
- Spring tension gives wrinkle free laid plastic.
- Unit floats independent of its three-point hitch, ensuring a smooth application.
- Highly adjustable to fit a all bed configurations.
- Drip tape irrigation attachment is optional.

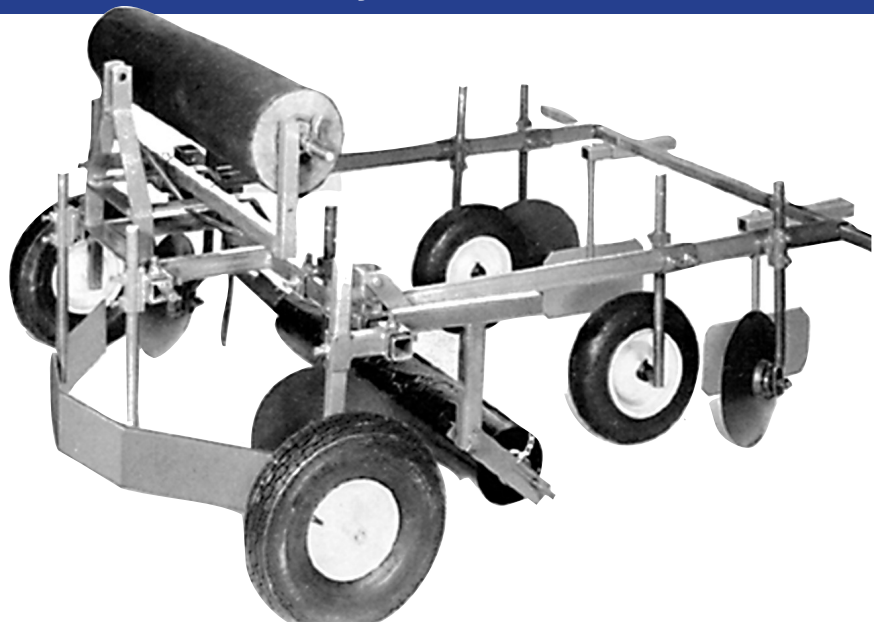

Part No	Description	Wt
46000	Model 1275 Mulch layer complete with Cat I 3-pt hitch, gauge wheels, leveling blade, rubber press wheels, floating main frame, 14" disc opening and covering blades, soils shields, and spare roll carrier.	500 lbs
Options		
49005	Drip irrigation attachment for mulch layer	90 lbs
49006	Fertilizer attachment for mulch layer	500 lbs

GASPARDO PLANTERS

Orietta Single Line Small Seed Planter



The Gaspardo Orietta is available in two chassis widths. The narrow chassis accepts 4" wide press wheels while the wide chassis accepts 7" wide press wheels. The narrow planter can be mounted as close as 5-1/2" apart and the wide planter 9" apart.

Features:

- Larger diameter seed disc for closer seed spacing or slower disc rotation.
- Drives a secondary singulator standard, two secondary singulators optional.

Seed Metering and Singulation:

Excellent singulation is due to the primary singulator (C) and the secondary singulator (D).

The agitator (A) stirs the seeds to assure good cell fill.

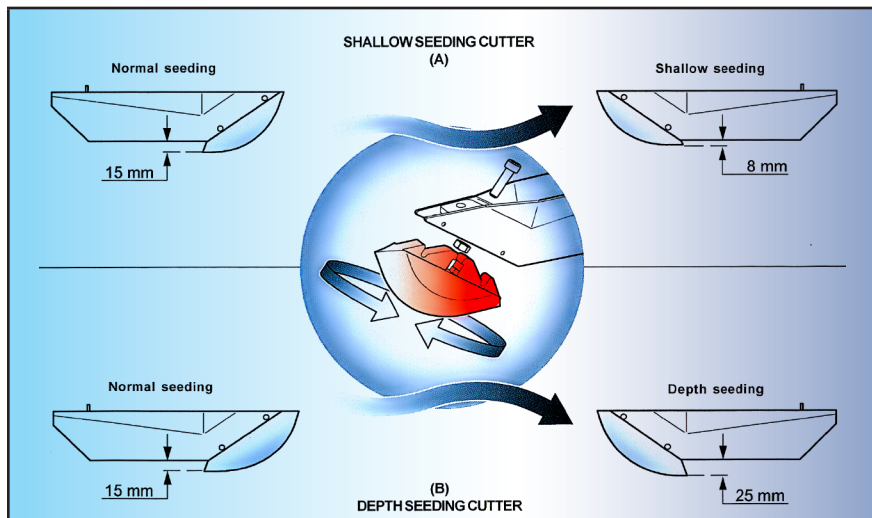
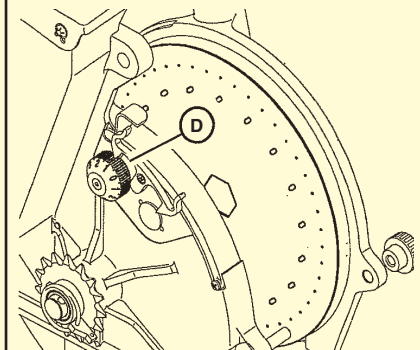
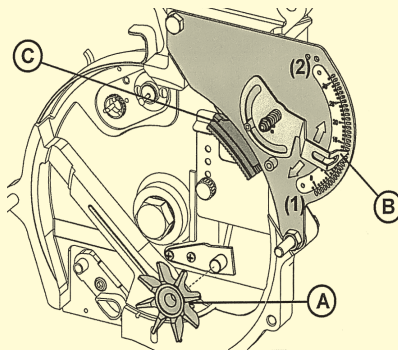

There are two reversible shoe castings available for different planting depths. Shallow for 8 to 15 mm and deep for 15 to 25 mm

GASPARDO PLANTERS

Olimpia Two-Line Small Seed Planter



Olimpia is available in two versions: narrow and wide chassis. Both versions feature two metering units per chassis.

The narrow chassis meters two lines 1-1/2" through 3-1/2" apart. The wide chassis meters two lines 4-1/4" to 5" apart.

Since each metering unit plants a single line, seed spacing is very accurate. And with two singulators per metering unit, singulation is excellent.



Seed Metering and Singulation:

Excellent singulation is due to the primary singulator (C) and the secondary singulator (D).

The agitator (A) stirs the seeds to assure good cell fill.

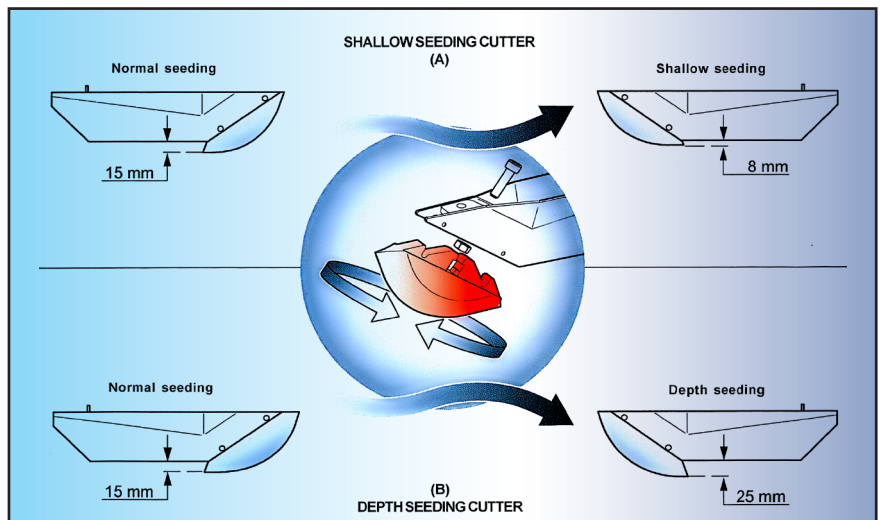
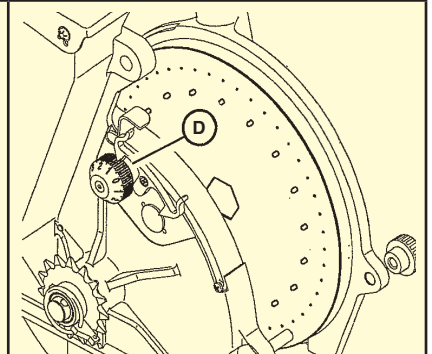
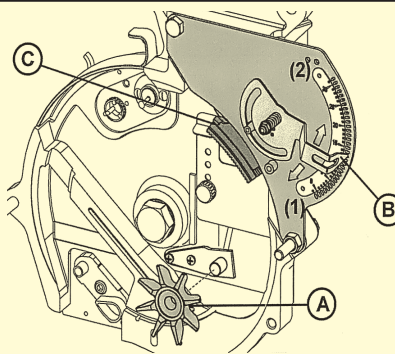

There are two reversible shoe castings available for different planting depths. Shallow for 8 to 15 mm and deep for 15 to 25 mm

GASPARDO PLANTERS

Model SP Large Seed Planter





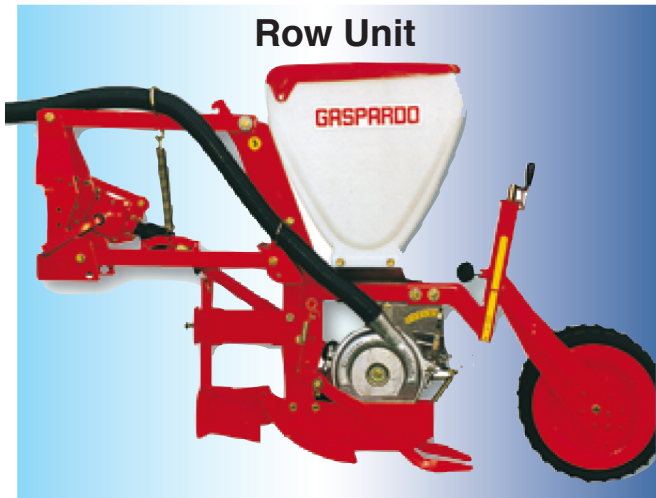

Features:

- Designed for seeds ranging in size from sugar beets to beans.
- Adjustable planting depth from 3/4" to 4"
- Seed spacing ranges from 1/2" to 329", controlled by number of holes in seed plate and ground drive wheel setting.
- Planting speed varies from 2 to 5 mph.
- PTO or hydraulic driven fan furnishes vacuum
- Category II/III hitch accepts 6 x 6 x 1/4" square bar.
- Planter can be spaced on toolbar from 12" apart.
- Planter will accept optional double disc opener.
- Short seed drop for uniform spacing.
- Large capacity 1 bushel seed hopper.

Row Unit



Press Wheel Options

			
<i>Farmflex Lo-Pressure Tire</i>	<i>2" Diameter Rubber V' Wheels</i>	<i>1" Diameter Rubber V' Wheels</i>	<i>Concave Rubber Wheel</i>

Model SP Singulator



Seeding Depth Adjustment

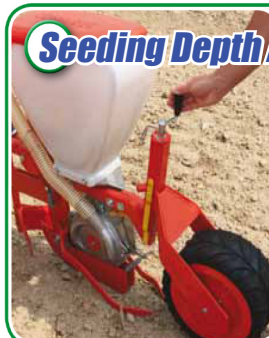

SEED SPIDER VEGETABLE SEEDER

High Density Vegetable Planter

Seed Spider lets you control seeding rate with the push of a button. An electric encoder motor driven sponge uniformly meters raw and coated seed, and each metering unit dispenses one to six lines. Seed spider adapts easily to existing planting sleds.

Seed rate controller and driver has GPS speed sensing. Each driver accepts up to eight metering units and the controller will accept up to three drivers. For smaller growers, an economy controller/driver is available that will accept up to four metering units.



Features:

- Canister empties quickly for changing crops.
- Seeds metered uniformly from line to line.
- Easy to understand calibration.
- Corrosion resistant stainless steel construction.
- Metering units removed quickly to prevent theft or damage during bad weather.
- 12v motors turn .3 rpm to 30 rpm in .1 rpm increments

Economy Sled



The Seed Spider economy sled provides an affordable chassis on which to mount the seed metering unit.



with LCD display



60 second removal & change



Accepts eight metering units



Unique design for even depth

Part No	Description
1" hose model	
1085.21	2 outlets, 1" hose
1085.31	3 outlets, 1" hose
1085.41	4 outlets, 1" hose
1085.51	5 outlets, 1" hose
1085.61	6 outlets, 1" hose
5/8" hose models	
1085.25	2 outlets, 5/8" hose
1085.35	3 outlets, 5/8" hose
1085.45	4 outlets, 5/8" hose
1085.55	5 outlets, 5/8" hose
1085.65	6 outlets, 5/8" hose
Controllers & Drivers	
1400	Controller
1401	Driver
1480	Controller/Driver
Sleds & Accessories	
AE 1550	Economy sled: 61"

SOLEX SEEDERS

Solex Vegetable seeder

- Cast iron and steel construction.
- Large capacity hoppers.
- Seed flow automatically cut off when unit is lifted.
- Front drive wheel levels seedbed and powers hopper.
- Concave press wheel with spring-loaded cleaner firms soil, leaving a loose zone over the seeds.
- Floating hitch allows drill to follow ground contours
- Enclosed gear drive
- Seed opener with adjustable depth slices a clean furrow. Six seed opener styles are available
- Adjustable floating coverer.

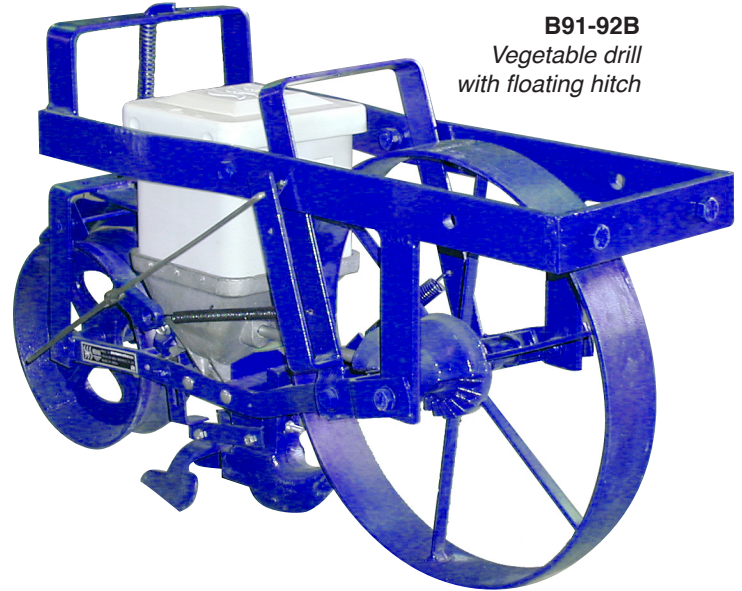

B91-92B
Vegetable drill
with floating hitch

Seed Opener Shoes



B0K-712
Standard



B0K-762
Hard soil



B0K-783
2" Scatter



B0K-769
4" Scatter

Part No.	Description	Wt
B91-92B	Vegetable Drill with floating hitch	59 lbs
B10-039X	Narrow Brush feed wheel. For gentle handling of seeds.	.5 lbs
B21-259	Mounting bracket for 2.5" corner-mounted toolbar. Adjustable Height, .75 x 2" shank	16 lbs

Solex Multipurpose Seeder

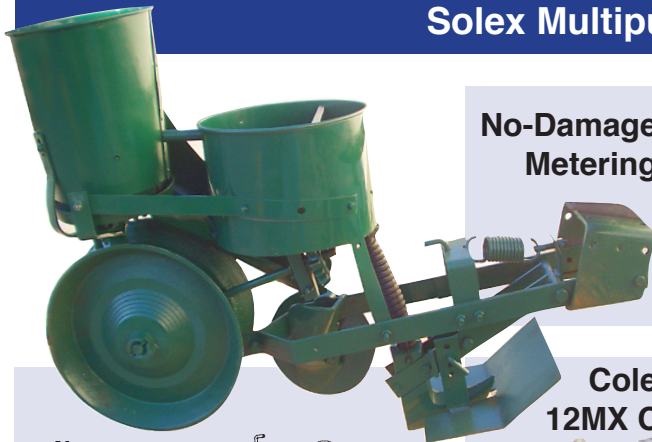

**No-Damage
Metering**

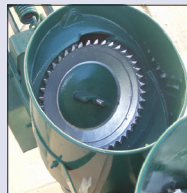

**Cole/Powell
12MX Compatible**



Parts interchange with Cole 12MX

- Simultaneously seeds and places fertilizer.
- Cast iron and steel construction
- Split cast iron press wheel with dirt scraper.
- Depth control handle.
- Deep-Vee seed opener floats independently of press wheel.
- Comes with four seed plates and four spacing gears
- Fertilizer rate adjustable from 34 to 650 pounds of fertilizer per acre.

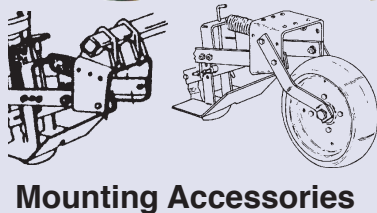

Mounting Accessories

Part No.	Description	Wt
12MXTB (1) 012-0103 (2) B46-670	Mounts To 2-1/4" and 2-1/2" Corner - Mounted Bars Planter w/ mounting brackets for multi-row application. Four seed plates and spacing gears with each unit.	181 lbs
(1) B46-676	Gauge Wheel - Mounts to Planter 12" wheel on sealed ball bearings. Zero-pressure rubber tire functions independently from tractor. Recommended for tractors w/o position control. Not for use with opening foot.	16 lbs

STANHAY PLANTERS

820 & 840 'Robin' Belt Planters

With a Stanhay Robin, any area, no matter how small, can be precision drilled with a minimum of effort and cost. Mounted behind compact tractors, ATVs, or even pushed by hand, the Robin will place seed with precision, leading to bigger yields, more uniform crops and reduced seed costs thanks to the unique Stanhay seed belt metering unit, renowned the world over for its accuracy, versatility and gentle handling of seed.

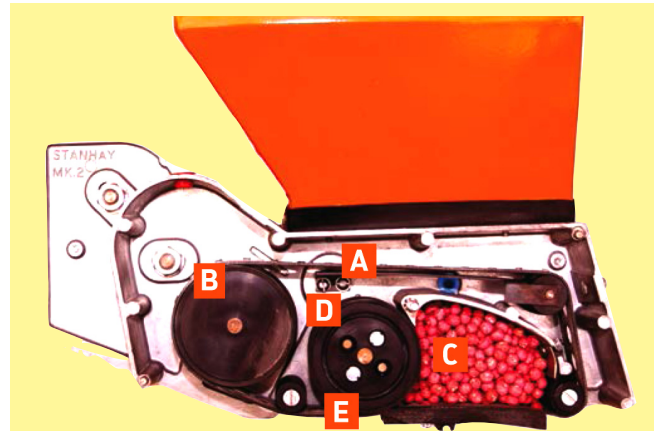

HOW IT WORKS

The principle of operation is clever yet very simple.

- The seedbelt (A) is rotated clockwise by the drivewheel (B)
- The choke (C) controls the seed entering the chamber
- The repeller wheel (D) agitates the seed and minimises doubles
- The base (E) is plain or grooved to suit the size of seed
- Seed is released as each hole reaches the end of the base

By fitting the right combination of choke, base and seedbelt (ribbed, plain or plastic) punched with the correct size and number of holes – in single, double or triple lines – you can plant almost any size of seed at any spacing or drilling pattern.

820 Hand Push Planter

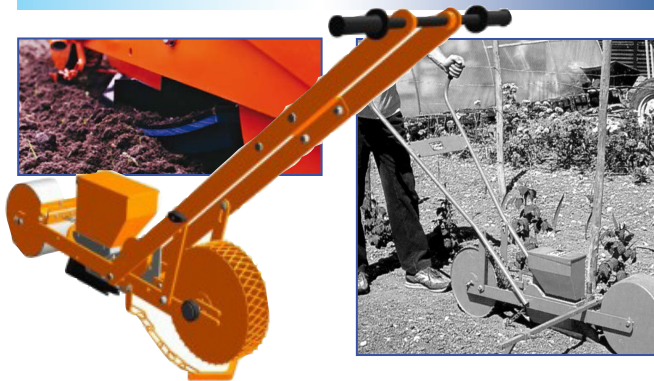

The versatile Robin 820 is designed for planting very small areas. With its large diameter wheels and ergonomic design, it requires very little effort to push. It is also very easy to maintain and operate.

- 4 spacing unit wheel drive
- High traction, cage rear wheel
- Easy-to-push chassis complete with row marker
- Drag-chain soil coverer
- Single line coulters standard
- Double or triple line coulters optional

840 Wheel Unit Planter



The Robin 840 is a low cost design for use behind small tractors or ATVs. High traction cage rear wheels drive each unit. A simple four pulley drive gives a choice of four different seed spacings per seed belt.

- 4 seed spacing unit wheel drive
- High traction, cage rear wheels
- Lightweight design for use with small tractors or ATVs
- Drag-chain soil coverer
- Single line coulters standard
- Double and triple line coulters are optional.

Model No	Description	Wt
8328000	Row of 820 Robin wheel unit planter, hand push chassis	86 lbs.
8541001	Row of 840 Robin wheel unit planter, tractor/atv pull	80 lbs.

Each row unit comes with: Plain Belt (1022002), A2 Base (2810017), and A Choke (6900040)

STANHAY PLANTERS

870 Precision Belt Planters



Stanhay planters are renowned for their low seed drop and remarkable versatility. They plant every seed type, and when used with pelleted seed their accuracy is near perfect. Adjustable height land wheels give a positive drive to all row units, whether planting on flat or raised beds.

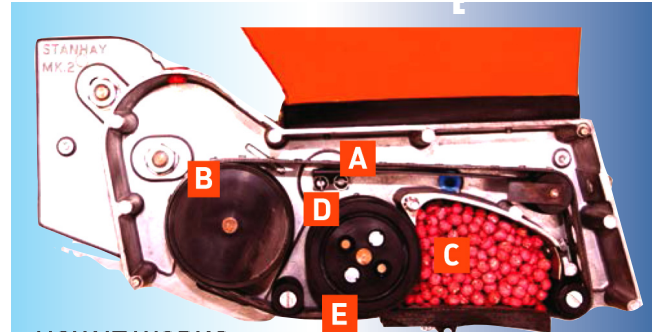

HOW IT WORKS

The principle of operation is clever yet very simple.

- The seedbelt (A) is rotated clockwise by the drivewheel (B)
- The choke (C) controls the seed entering the chamber
- The repeller wheel (D) agitates the seed and minimises doubles
- The base (E) is plain or grooved to suit the size of seed
- Seed is released as each hole reaches the end of the base

By fitting the right combination of choke, base and seedbelt (ribbed, plain or plastic) punched with the correct size and number of holes – in single, double or triple lines – you can plant almost any size of seed at any spacing or drilling pattern.

- Free floating chassis.
- Landwheel drive with belt and pulley transmission
- Electronic rotation monitor option
- Accurate seed spacing & total control of plant density
- Choice of coulters for all seed patterns and soil types.
- Kind on seeds
- Low maintenance costs

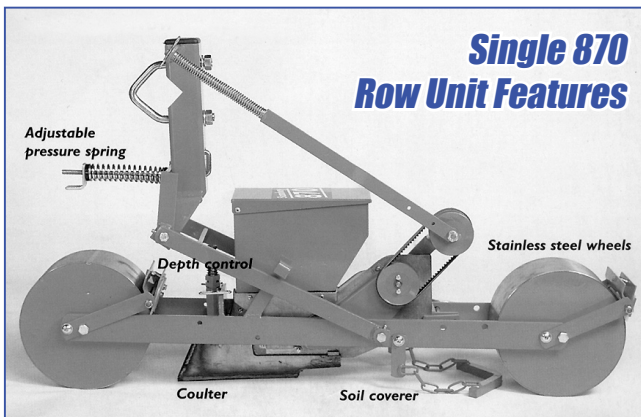

Planting “Tailor Made” For Your Needs

Single Line	Double Line	Triple Line

Choice of choke, base, and seedbelt allow almost any size of seed at any spacing or drilling pattern:

- **Double or triple line spacing** - two line 1-1/2", 2", or 3" apart or three lines 1" or 1-1/2" apart
- **Wide spacings and group drilling** - For example, place a group of three seeds 1" apart with a 12" gap between group centers.

Model No	Description	Wt (lbs)
S870-2B	2 row planter	520
S870-4	4 row planter	700
S870-6	6 row 870 planter	900
S870-8	8 row 870 planter	1100
Individual 870 Components		
6902322	Hex shaft	
7702982	98 Inch toolbar	
7701116	168 Inch toolbar	
8002751	3 Point hitch for 98" toolbar	
7403031	3-pt hitch for 168" toolbar	
8002677	Hitch brackets	

Model No	Description	Wt (lbs)
Individual 870 Components (cont'd)		
7700996	Bearing and bracket	
8542031	S870 Planter with SS wheels	
8003152	Support wheel	
8003145	4 Spacing V-belt drive	
8003146	4 Spacing V-belt drive	
7700089	Coupler	
6417133W	S870 Operation Manual	
7400034	Coulter	
7702095	Parking Stand	
STY10	Seed belt kit	

STANHAY PLANTERS

Star High-Precision Multi-line Vacuum Planter

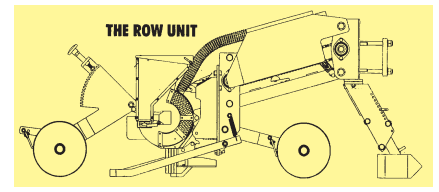

The most versatile and precise drill for growers of vegetable or salad crops.

Parallel linkage allows the row unit to follow the ground for accurate, consistent seed depth. Down pressure is adjustable via spring preload between the top and bottom links. Depth control adjustable via rear wheel arm.

The drive chain is encased between the parallel link, lessening the chance of 'chain jump' and seed misses.

Standard Features:

- Adjustable pressure parallel linkage
- Rubber zero-pressure front wheels
- 120mm rear wheels with cleaners.
- Adjustable pressure to chassis arm
- Easy rear wheel depth adjustment
- 2 liter seed hopper
- Arm or drag-type seed covers



Single Line



Double Line

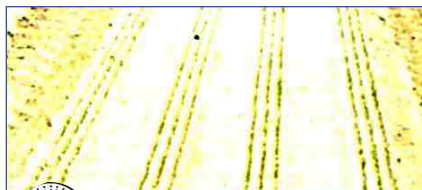

Triple Line



Four Line

Transport Options

Hydraulic End-Tow



Hydraulic Stacker bar



Model	Description
Star-2B	2 Unit Star, 98" toolbar
Star-4	4 Unit Star
Star-6	6 Unit Star
Star-8	8 Unit Star
10520081	Hyd. drive assembly
8002617	single line cast
8002550	single line ceramic
7703504	single line non-stick
7703308	2 line 2.5" hyline non-stick
7703309	3 line 1.25" hyline non-stick
7703310	3 line 3" hyline non-stick
7703311	3 line 1.5" hyline non-stick
7703312	2 line 4" hyline non-stick
7703313	3 line 2" hyline non-stick
7703377	2 line 5" hyline non-stick
7703379	3 line 2.5" hyline non-stick
7703314	2 line 6" hyline non-stick
7703315	3 line 3" hyline non-stick
7703263	2 line 3" hyline deep fin
7703264	3 line 1.5" hyline deep fin

STANHAY PLANTERS

S780 Handcrank Adjustable Planter for High Density Crops



The Stanhay 780 drill is designed for the grower of high density crops.

The slim line chassis combined with Stanhay's high density 'slimline' seed hopper makes 150 mm row unit centres achievable. Coupled with Stanhay's unique ability to plant up to 4 lines from one row unit, the Stanhay 780 drill gives the maximum planting density available and with Stanhay's minimum seed drop height, precision placement is assured through the elimination of seeds 'bouncing' when dropped from greater height.

As with all Stanhay drills seed discs can accommodate up to 4 lines of either pelleted, coated or raw seed. The 780 drill is air operated and landwheel driven.

Standard features include a Cat II Hitch, 12 spacing transmission, 540 PTO shaft with over run clutch, zero pressure wheels, drag covers and single sided chassis.

Features:

- Adjust planting depth quickly and easily.
- Capable of high density planting (2" line to line).
- Short seed drop for accurate spacing.
- Drive chain installed in fixed position to insure smooth operation.

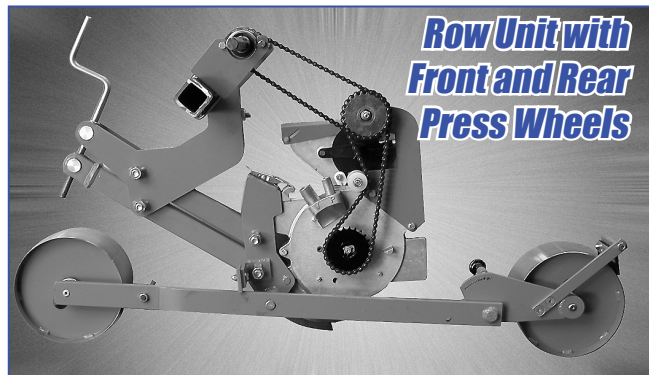



RINIERI VINEYARD IMPLEMENTS

EL Series Under-Row Cultivator





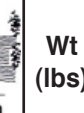



The hydraulic offset cultivators with 4 vertical rotary tine sets are ideal for tilling vineyards and orchards in rows with close plantings (at least 50 cm. apart). EL performs a good weeding at a minimum working depth, ensures an optimum soil leveling without creating any ditch during its side displacement.

Code	Model	 cm min	 cm max	 cm	 cm	Wt (lbs)
60793m	EL70	100	70	65	40	506
60720M	EL90	140	90	65	40	572
60730M	EL115	170	115	65	50	660
60740M	EL140	200	140	65	50	704
60750M	EL170	250	170	65	55	748
60751M	EL170/100	270	205	100	60	946
60760M	EL200	300	200	65	60	902
60761M	EL200/100	320	235	100	60	1056
60770M	EL225	350	225	65	60	946
607780M	EL225/100	450	260	100	60	1100
18020	Hyd. safety control. Lever override					
18030	Electro-hydraulic push button safety control.					
18050	Kit sensor rod control and electrohydraulic emergency push button (like ELX)					
10392	Wheels (EL200-225 wheels std)					
10820	Articulated attachment for stone soil					
60331	Hyd. depth adjustment (only EL 200-260)					

ELX Under-row Cultivator

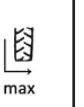
ELX combines sturdiness with reduced width for big reliability in stony soils. The machine has a three-arm sideshift, anti-shock gas cylinder for dampening and a special PTO shaft with a ratchet-style torque limiter. It is ideal for demanding customers who have to work in difficult stony and hard soil.

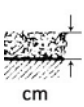

Code	Model	 cm min	 cm max	 cm	 cm	 Km/h		 cm
60789M	ELX 115	170	115	65	50	4	814 lbs	5 - 10
60790M	ELX 140	200	140	65	50	4	858 lbs	5 - 10

RINIERI VINEYARD IMPLEMENTS

CRV Eco Pruning Machine with vertical blades



Illustration	Code	Model	No of Blades	Cut size
				Fig A
A	6ECOV140	CRV B1 ECO I	4	140 cm
	6ECOV150	CRV B1 ECO I	5	175 cm
A	6ECOV240	CRV B2 I/I	4 + 4	140 cm
	6ECOV250	CRV B2 1/1	5 + 5	175 cm
Options				
	35591	Hyd. side displacement cylinder		
	33080	Shoot conveyor		
	32792	Coupling frame (specify tractor)		
	10890	3 pt coupling for front mount		
	33081	1 blade top bar w/ manual tilt		
	33082	2 blade top bar w/ manual tilt		
	33086	1 blade bottom bar w/ manual tilt		

CRV Blade Pruning Machine "U Reverse"

Linked to a reinforced standard frame comple with: 3 hydraulic movement (lift, side shift, and tilt), hydraulic distributor, support, spring-shockproof



Illustration	Code	Model	No of Blades	Cut (cm)
			A • B	A • B
B	6CRV3D0	CRV B1 U ROV	3 • 2	105 • 75
	6CRV3C0	CRV B1 U ROV	4 • 2	140 • 75
	6CRV3B0	CRV B1 U ROV	5 • 2	175 • 75
Options				
	"E"	add electro hyd controls 4+1 for cab		
	"P"	add electro hyd. controls with proportional joystick 4+1		
	32792	Coupling frame (specify tractor)		
	10890	3 pt coupling for front mount		
	"T"	Less hydraulic distributor		
	33065	90° rotation for transport		
A	6CRV3D0P	"PA" frame with hydraulic side shift of the vertical support for transport.		
	6CRV3C0P			
	6CRV3B0P			

RINIERI VINEYARD IMPLEMENTS

Model CRV Pruning Machine with Vertical Bar



Model B1



Model B1SB

Std. frame with: Hydraulic lift, side shift, tilt • hydraulic distributor • support • spring-shockproof

Illustration	Code	Model	No of Blades	Cut size
				Fig A
A	6CRV130	CRV B1 I	3	105 cm
	6CRV140	CRV B1 I	4	140 cm
	6CRV150	CRV B1 I	5	175 cm
A	6CRV830	CRV B1 SB I	3	105 cm
	6CRV840	CRV B1 SB I	4	140 cm
	6CRV850	CRVB1 SB I	5	175 cm
Options				
	"E"	Controls with joystick 4+1 for tractor cab		
	"P"	Controls with proportional joystick 4+1		
	33080	Shoot conveyor		
	32792	Coupling frame (specify tractor)		
	10890	3 pt coupling for front mount		
	33086	1 blade bottom bar w/ manual tilt		
	33081	1 blade top bar w/ manual tilt		
	33082	2 blade top bar w/ manual tilt		
	"T"	less hydraulic distributor		

Model CRV Pruning Machine with Vertical Bar and Top Bars

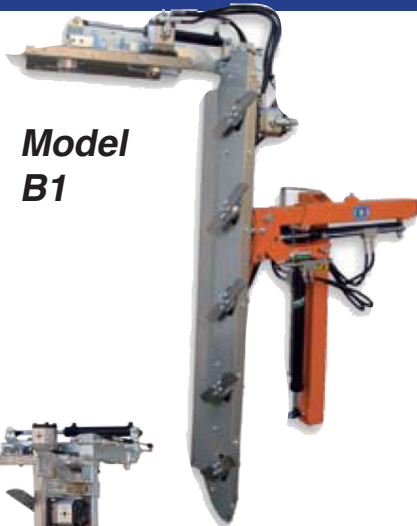

Model B1



Model B1SB

Std. frame with: Hydraulic lift, side shift, tilt • hydraulic distributor • support • spring-shockproof

Illustration	Code	Model	Blades	Cut size (cm)
			Fig A • B	Fig A • B
B A	6CRV131	CRV B1 LR	3 • 1	105 • 45
	6CRV132	CRV B1 LR	3 • 2	105 • 80
	6CRV141	CRV B1 LR	4 • 1	140 • 45
	6CRV142	CRV B1 LR	4 • 2	140 • 80
	6CRV151	CRV B1 LR	5 • 1	175 • 45
	6CRV152	CRV B1 LR	5 • 2	175 • 80
B A	6CRV831	CRV B1 SB LR	3 • 1	105 • 45
	6CRV832	CRV B1 SB LR	3 • 2	105 • 80
	6CRV841	CRV B1 SB LR	4 • 1	140 • 45
	6CRV842	CRV B1 SB LR	4 • 2	140 • 80
	6CRV851	CRV B1 SB LR	5 • 1	175 • 45
	6CRV852	CRV B1 SB LR	5 • 2	175 • 80
Options				
	"E"	Controls with joystick 4+1 for tractor cab		
	"P"	Controls with proportional joystick 4+1		
	33080	Shoot conveyor		
	32792	Coupling frame (specify tractor)		
	10890	3 pt coupling for front mount		
	33086	1 blade bottom bar w/ manual tilt		
	"T"	less hydraulic distributor		

RINIERI VINEYARD IMPLEMENTS

Double Blade Pruning Machine "CRV" with Vertical Bars



Std. frame with: Five hydraulic movements (lift, side shift, tilt) • hydraulic distributor Support • spring-shockproof

Illustration	Code	Model	No of Blades	Cut size
				Fig A
	6CRV230	CRV B2 I/I	3	105 cm
	6CRV240	CRV B2 I/I!	4	140 cm
	6CRV250	CRV B2 I/I	5	175 cm
Options				
	" +E"	Electro-hydraulic controls with joystick 7+1 for tractor cab		
	33080	Shoot conveyor		
	32785	Coupling frame for double side machines (specify tractor model)		
	10890	3 pt coupling for front mount		
	33086	1 blade bottom bar w/ manual tilt		
	33081	1 blade top bar w/ manual tilt		
	33082	2 blade top bar w/ manual tilt		
	" +T"	less hydraulic distributor		

Double Blade Pruning Machine "CRV" with Vertical Bar and Top Bars



Double frame complete with: Seven hydraulic movements (lift, side shift, tilt, upper head angle), hydraulic distributor • support • spring-shockproof

Illustration	Code	Model	Blades	Cut size (cm)
			Fig A • B	Fig A • B
	6CRV231	CRV B2 L/L R.	3 • 1	105 • 45
	6CRV232	CRV B2 L/L R.	3 • 2	105 • 80
	6CRV241	CRV B2 L/L R.	4 • 1	140 • 45
	6CRV242	CRV B2 L/L R.	4 • 2	140 • 80
	6CRV251	CRV B2 L/L R.	5 • 1	175 • 45
	6CRV252	CRV B2 L/L R.	5 • 2	175 • 80
Options				
	" +E"	Electro-hydraulic controls with joystick 4+1 for tractor cab		
	33080	Shoot conveyor		
	32785	Coupling frame for double sided machine (specify tractor)		
	10890	3 pt coupling for front mount		
	33086	1 blade bottom bar w/ manual tilt		

RINIERI VINEYARD IMPLEMENTS

Double Blade Pruner On A Low Shifting Frame with Vertical Bars



- Double frame for high visibility complete with:
- Five hydraulic movements (lift, side shift, tilt),
- Hydraulic distributor
- Support and spring shockproof

Code	Model	No of Blades	Cut size
			Fig A
6CDV230	CDV I/I	3	105 cm
6CDV240	CDV I/I	4	140 cm
6CDV250	CDVI/I	5	175 cm
"E"	Electro-hydraulic controls with joystick 7+1 for tractor cab		
33080	Shoot conveyor		
32785	Coupling frame for double side machines (specify tractor model)		
10890	3 pt coupling for front mount		
33086	1 blade bottom bar w/ manual tilt		
33081	1 blade top bar w/ manual tilt		
33082	2 blade top bar w/ manual tilt		
"T"	less hydraulic distributor		

Double Blade Pruner on a Low Shifting Frame, Vertical & Top Bars

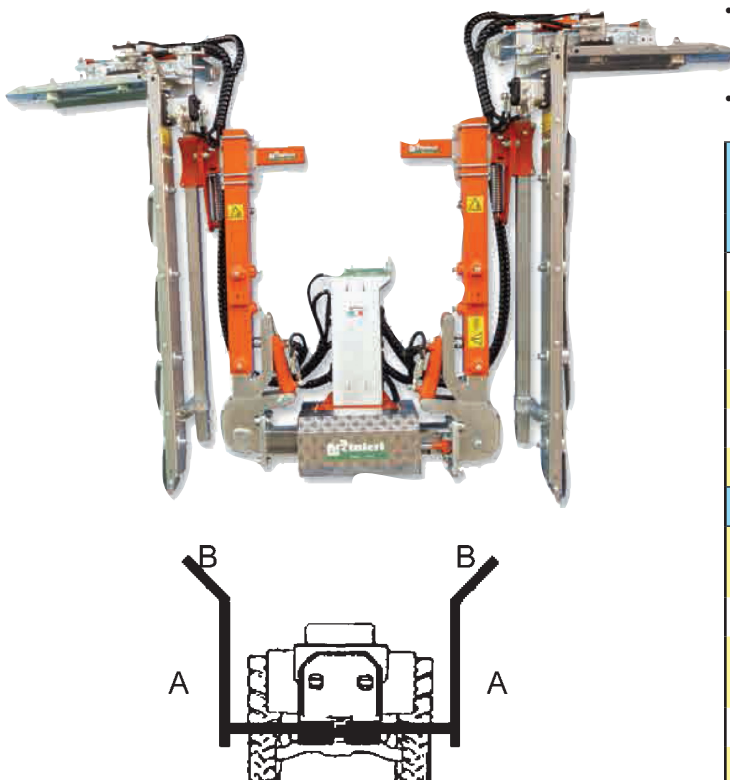

- Double frame for high visibility complete with:
- Seven hydraulic movements (lift, side shift, tilt, head angle).
- Hydraulic distributor, support and spring-shockproof

Code	Model	Blades	Cut size (cm)
		Fig A • B	Fig A • B
6CDV231	CRV L/L R	3 • 1	105 • 45
6CDV232	CRV L/L R	3 • 2	105 • 80
6CDV241	CRV L/L R	4 • 1	140 • 45
6CDV242	CRV L/L R	4 • 2	140 • 80
6CDV251	CRV L/L R	5 • 1	175 • 45
6CDV252	CRV L/L R	5 • 2	175 • 80
"E"	Electro-hydraulic controls with joystick 4+1 for tractor cab		
33080	Shoot conveyor		
32785	Coupling frame for double sided machine(specify tractor model)		
10890	3 pt coupling for front mount		
33086	1 blade bottom bar w/ manual tilt		

RINIERI VINEYARD IMPLEMENTS

DRV Leaf Remover

- Head with 55cm diameter fan:
- 4 hyd movements (lift, side shift, angle, 180° rotation)
- Independent distributor & Support

Code	Model
6DRV656	DRV B1 G56
Options	
" +E"	Electro-hydraulic controls with joystick 4+1 for tractor cab
" +P"	Price Increase for electro-hydraulic controls with proportional joystick 4+1
32792	Couplig frame (specify tractor model)
10890	3 pt coupling for front mount
" +T"	Less hydraulic distributor
6DRV056	Leaf Remover head with 55cm diameter fan for pruning machine frame.



6DRV056
Option head only
For Pruner frame

CPL Disc Pre Pruner

**CPL
Pre
Pruner**



**B1
Frame**

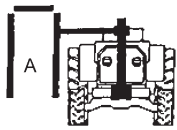

**BS1B
Frame**

Code	Model	Discs	Cut Size (Fig A)	Illustration
39994	CPL 4	4 + 4	300 cm	
39996	CPL 6	6 + 6	500 cm	
39998	CPL 8	8 + 8	700 cm	
39990	CPL 10	10 + 10	900 cm	
Options				
32781	B1 frame for CPL complete with 3 hydraulic movements, independent distributor and support			
34590	B1SB frame for CPL complete with 3 hydraulic movements, independent distributor, and support			
" +E"	Electro-hydraulic controls with joystick 4+1 for tractor cab			
" +P"	Electro-hydraulic controls, with proportional joystick 4+1			
32792	Coupling frame (specify tractor)			
10890	3 pt coupling for front mount			
60309	Independent hyd. kit with 30 lt pump, 50l oil tank, and pto			
60350	Oil cooler for hydraulic kit			