



PROJET

AGRICULTURE



Un mondo di soluzioni

A lot of solutions - Un monde de solutions - Viele Lösungen - Un mónton de soluciónes

www.progroup.it

pro
GROUP



PRO

AG



Un mondo c

A lot of solutions - Un monde de solutions -

PROFESS

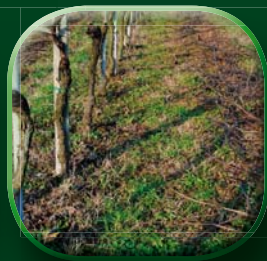



ET

AGRICULTURE



di soluzioni

Viele Lösungen - Un montón de soluciones

IONAL LINE



TECNICA • Sistema Di Trinciatura

TECHNICAL • Mulching System

TECHNIQUE • Systeme De Broyage

TECHNISCHE • Hackerung systeme

TÉCNICA • Sistemas de picar

5

- KIT SPUNTONI
- COLLECTION PINS
- SAILLE DE COLLECTAGE
- SAMMELZACKEN
- PUNTAS PARA COSECHA

1

- MOLTIPLICATORE CON PROLUNGA
- GEAR BOX WITH EXTENSION
- BOITIER AVEC ROLLANGE
- GETRIEBE MIT VERLÄNGERUNG
- MULTIPLICADOR CON EXTENSIÓN

2

- SPOSTAMENTO IDRAULICO - MANUALE
- SIDESHIFT HYDRAULIC - MECHANICAL
- DEPLACEMENT HYDRAULIQUE - MECANIQUE
- SEITENVERSCHIEBUNG HIDRAULISCHE
- DESPLAZAMIENTO HYDRÁULICO

3

- KIT RUOTA ANTERIORE
- FRONT WHEEL KIT
- KIT ROUE ANTERIEURE
- VORNERAD KIT
- KIT RUEDA DELANTERA

4

- FLANGIA PROTEZIONE PIANTA
- HYDRAULIC SIDE SHIFT
- DEPLACEMENT HYDRAULIQUE
- HYDRAULISCHE ZEITENVERSCHIEBUNG
- DESPLAZAMIENTO HYDRÁULICO

1







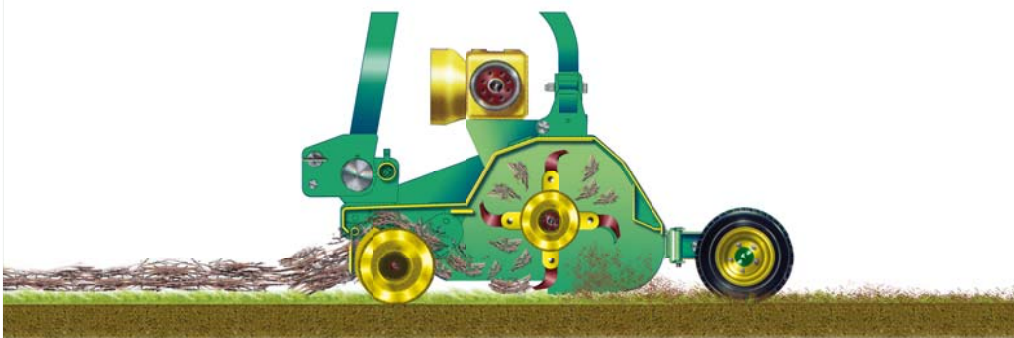
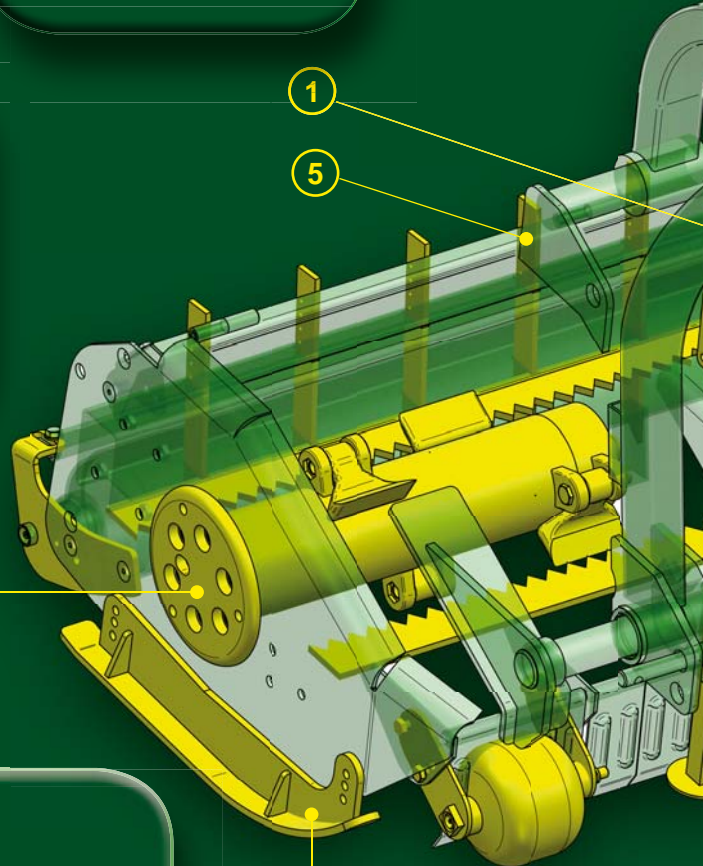

4

1

5

6



-  CONFIGURAZIONE DELLA STRUTTURA PORTANTE
-  CONFIGURATION OF THE SUPPORTING STRUCTURE
-  CONFIGURATION DE LA STRUCTURE DE SUPPORT
-  KONFIGURATION DER TRÄGERSTRUKTUR
-  CONFIGURACIÓN DE LA ESTRUCTURA DE SOPORTE

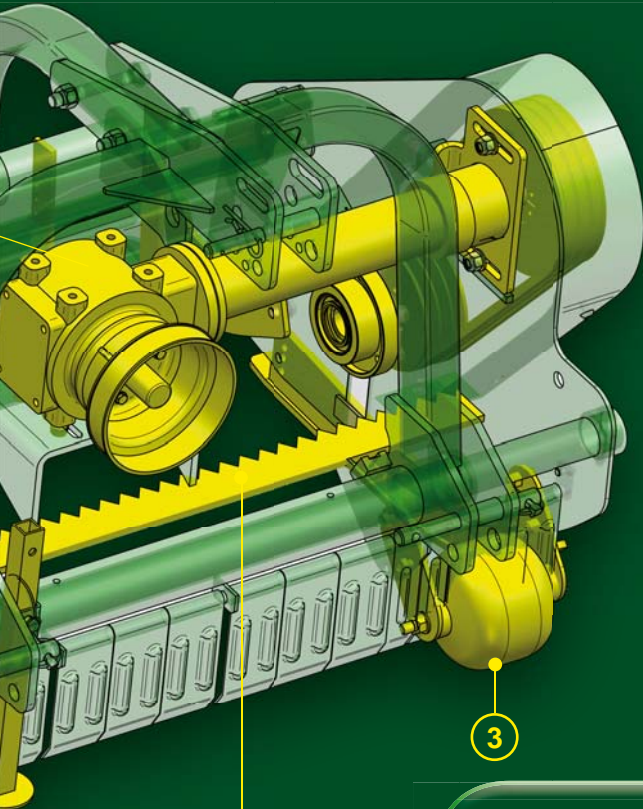

3

9

2



PROIE
AGI

Un mondo

A lot of solutions - Un monde de solutions -

PROFESS

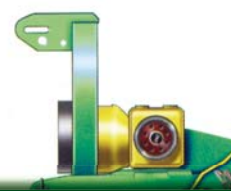



- 🇮🇹 CONFIGURAZIONE DEL SISTEMA DI TRASMISSIONE
- 🇬🇧 DRIVE SYSTEM CONFIGURATION
- 🇫🇷 CONFIGURATION DU SYSTÈME DE TRANSMISSION
- 🇩🇪 KONFIGURATION DES ÜBERTRAGUNGSSYSTEME
- 🇪🇸 CONFIGURACIÓN DEL SISTEMA DE TRANSMISIÓN

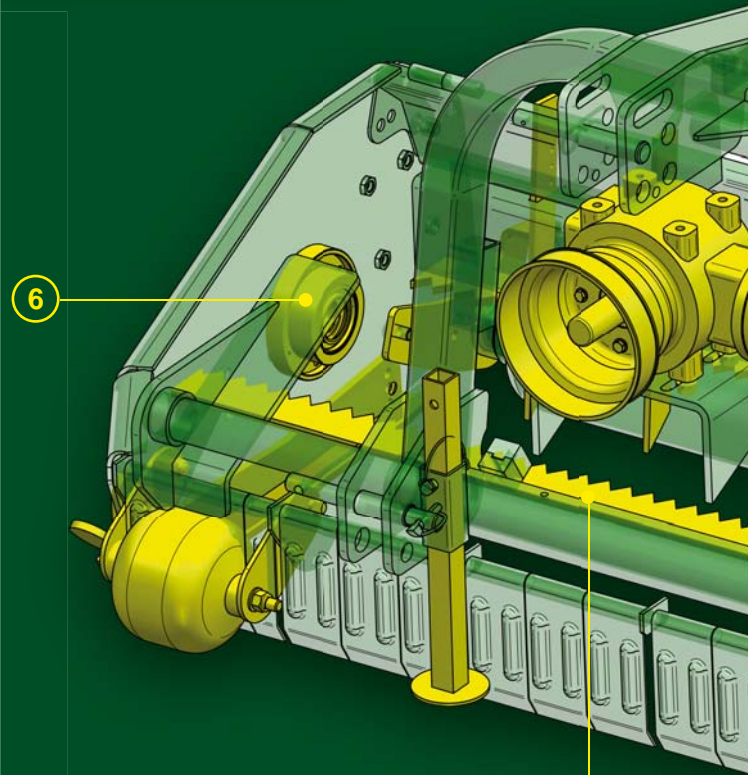

di soluzioni

Viele Lösungen - Un montón de soluciones

IONAL LINE

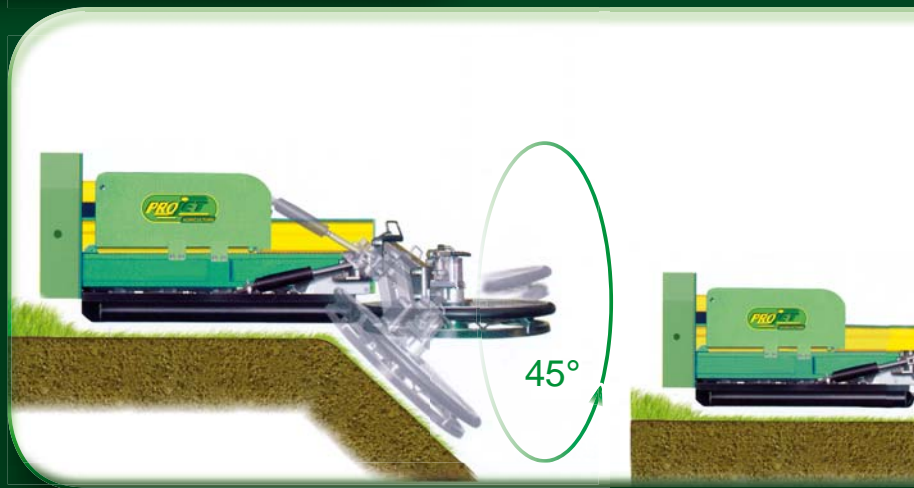
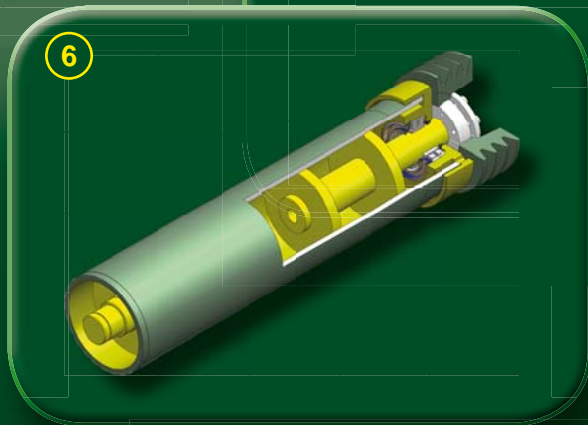

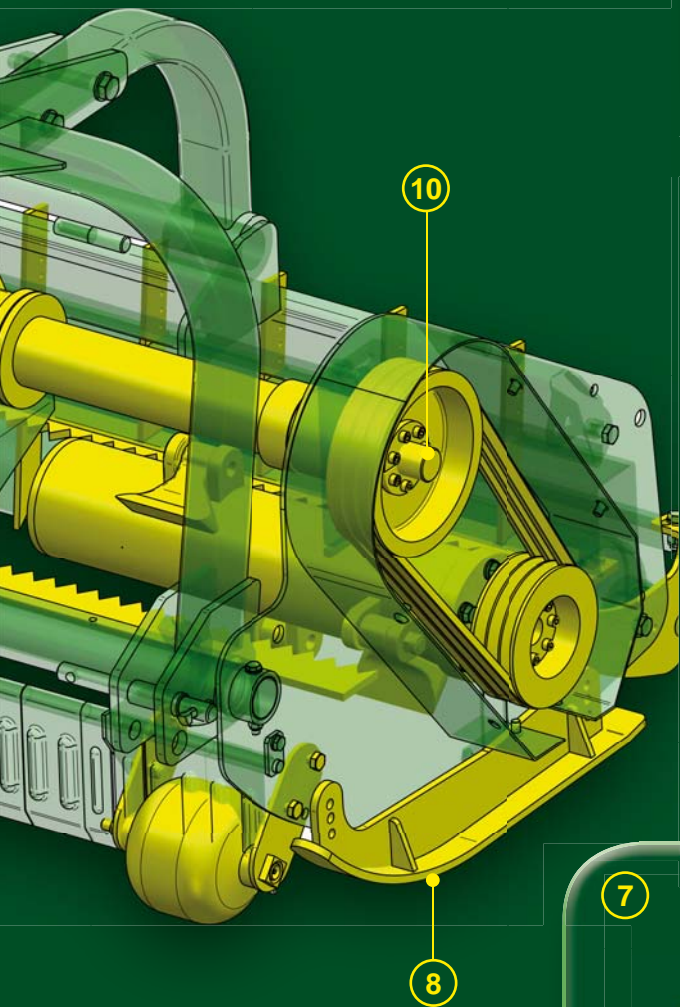

6

-  SPECIALE SUPPORTO ROTORE
-  SPECIAL ROTOR SUPPORT
-  SPÉCIAL SOUTIEN DE ROTOR
-  SPEZIELLE UNTERSTÜTZUNG DES ROTOR
-  ESPECIAL APOYO DE ROTOR

7

-  GRUPPO SUPPORTO RULLO
-  GROUP OF ROLLER SUPPORT
-  GROUPE DE SUPPORT ROULEAU
-  GRUPPE UNTERSTÜTZUNG LAUFROLLE
-  GRUPO APOYO DE RODILLO





8

-  KIT SLITTE
-  WEARING SKIDS KIT
-  KIT PATINS LATÉRAUX
-  KIT SEITLICHE GLEITKUFEN
-  KIT DERRAPES LATERALES

9





-  KIT CONTRO COLTELLI
-  COUNTER KNIVES KIT
-  KIT CONTRE-COUTEAUX
-  KIT GEGENMESSER
-  KIT CONTRACOUCHILLAS

10

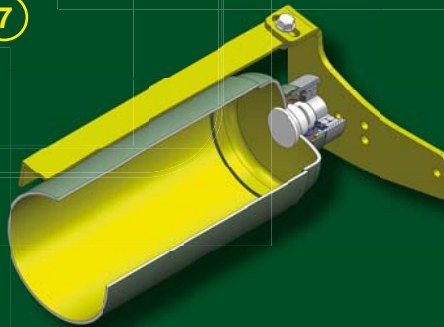
-  KIT PULEGGIE CON CALETTATORE
-  KIT OF PULLEYS WITH COUPLING
-  KIT DE POULIES AVEC FRETTE DE SERRAGE
-  KIT RIEMENSCHIBEN MIT VERRIEGELUNG
-  KIT POLEAS CON ANILLO DE CONTRACCIÓN

7



-  I dati e le descrizioni del presente opuscolo hanno soltanto valore indicativo.
-  The specifications and descriptions in the brochure are purely indicative.
-  Les données et les caractéristiques de cette brochure ne sont fournies qu'à titre indicatif.
-  Broschüre Aufgeführten Daten und Merkmale gel ten als Richtlinie.
-  Los datos y las descripciones del presente folleto tienen solamente valor indicativo y podran ser cambiados sin previo aviso.

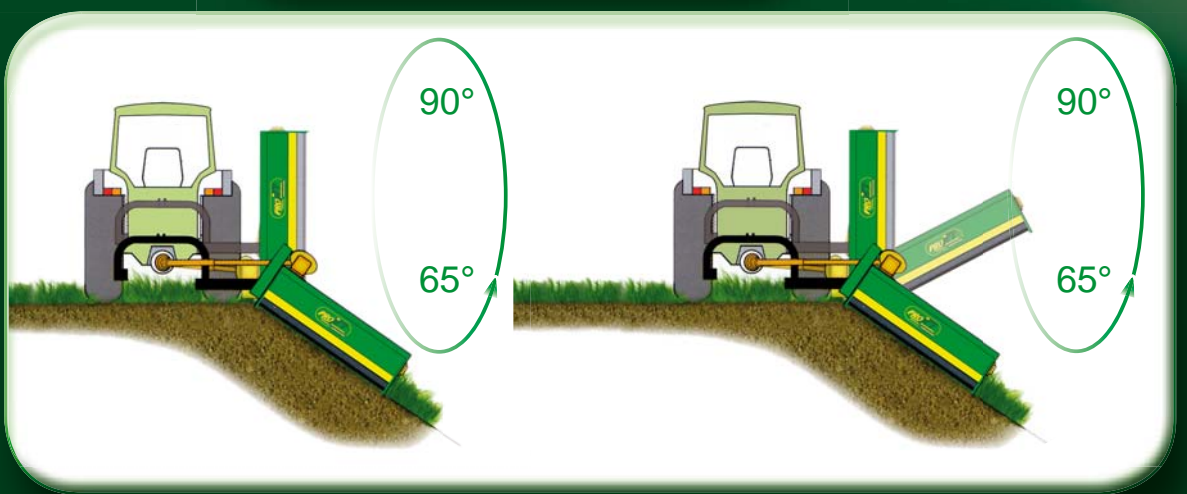
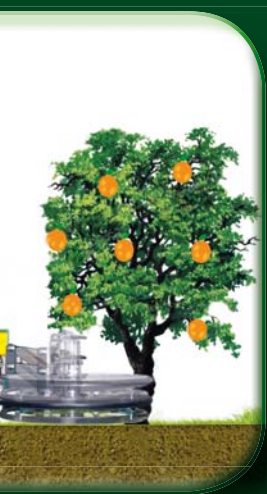

Un mondo di soluzioni

A lot of solutions - Un monde de solutions - Viele Lösungen - Un mónnton de soluciónes

PTK

PROJET

AGRICULTURE



CARATTERISTICHE TECNICHE DI SERIE:
TRINCIAERBA PER MOTOCOLTIVATORI • SCATOLA INGRANAGGI IN GHISA CON RUOTA LIBERA INTERNA A BAGNO D'OLIO • FLANGIA ATTACCO PER MOTOCOLTIVATORE • RULLO REGOLABILE • REVERSIBILE TIPO FRESA O FALCIATRICE • COLTELLI UNIVERSALI • PROTEZIONI ANTINFORTUNISTICHE A NORME CE

CURRENT TECHNICAL FEATURES: GRASS SHREDDER ENGINE-DRIVEN CULTIVATORS • CAST IRON GEAR BOX WITH INSIDE OILBATH FREE WHEEL • COUPLING FLANGE FOR ENGINE-DRIVEN CULTIVATOR • ADJUSTABLE ROLLER • MILLER OR MOWER-LIKE REVERSIBLE • UNIVERSAL KNIVES • CE STANDARD ACCIDENT PREVENTION GUARDS

CARACTERISTIQUES TECHNIQUES DE SERIE: HACHE-HERBE POUR MOTOCULTEUR • BOITE D'ENGRENAGES EN FONTE AVEC RAPPORT EN BAIN D'HUILE • BRIDE D'ATTACHEMENT POUR MOTOCULTEUR • GALET REGLABLE, REVERSIBLE TYPE FRAISE OU FAUCHEUSE • COUTEAUX UNIVERSELS • PROTECTIONS CONTRE LES ACCIDENTS DU TRAVAIL CONFORMES AUX NORMES CE

TECHNISCHE SERIENDATEN: GRASMÄHER FÜR ACKERBAUMASCHINEN • GETRIEBEGEHÄUSE AUS GUSSEISEN MIT INNEREM FREILAUF IN ÖLBAD • FLANSCHKUPPLUNG FÜR ACKERBAUMASCHINEN • REGULIERBARE WALZE • UMKEHRBAR: FRÄSE ODER MÄHER • UNIVERSALE MESSERKLINGEN • SCHUTZVORRICHTUNGEN, DIE DEN CE NORMEN ENTSPRECHEN

CARACTERÍSTICAS TÉCNICAS DE SERIE: TRINCHADORA DE HIERBA PARA MOTOCULTIVADORES • CAJA DE ENGRANAJES DE HIERRO FUNDIDO CON RUEDA LIBRE. INTERNA EN BAÑO DE ACEITE • BRIDA DE ENGANCHE PARA MOTOCULTIVADORES • RODILLO REGULABLE • REVERSIBLE TIPO FRESA O SEGADORA • CUCHILLAS UNIVERSALES • PROTECCIONES CONTRA ACCIDENTES SEGUN NORMAS CE

COLTELLI Y 406
KNIVES Y 406
COUTEAUX Y 406
MESSER Y 406
COUCHILLAS Y 406

MAZZE MS 60
HAMMER MS 60
FLEAUX MS 60
HAMMER MS 60
MAZAS MS 60

PTK									
	mm	Hp	Y406	MS 60	n°	A	B	C	Kg
50	480	5 - 6	14	-	2	700	380	560	61
60	580	7 - 10	16	-	2	700	380	660	68
70	680	9 - 12	18	9	2	700	380	760	79
80	780	10 - 14	22	11	2	700	380	860	91
90	880	12 - 16	24	12	2	700	380	960	100
100	980	14 - 18	24	12	3	700	380	1090	112
120	1180	18 - 20	32	16	3	700	380	1290	131

PROFESSIONAL LINE

HBK



CARATTERISTICHE TECNICHE DI SERIE: TRINCIAERBA PER MOTOCOLTIVATORI • SCATOLA INGRANAGGI IN GHISA CON RUOTA LIBERA INTERNA A BAGNO D'OLIO • FLANGIA ATTACCO PER MOTOCOLTIVATORE • RULLO REGOLABILE • REVERSIBILE TIPO FRESA O FALCIATRICE • COLTELLI UNIVERSALI • PROTEZIONI ANTINFORTUNISTICHE A NORME CE

CURRENT TECHNICAL FEATURES: TRINCIAERBA PER MOTOCOLTIVATORI • SCATOLA INGRANAGGI IN GHISA CON RUOTA LIBERA INTERNA A BAGNO D'OLIO • FLANGIA ATTACCO PER MOTOCOLTIVATORE • RULLO REGOLABILE • REVERSIBILE TIPO FRESA O FALCIATRICE • COLTELLI UNIVERSALI • PROTEZIONI ANTINFORTUNISTICHE A NORME CE

CARACTERISTIQUES TECHNIQUES DE SERIE: TRINCIAERBA PER MOTOCOLTIVATORI • SCATOLA INGRANAGGI IN GHISA CON RUOTA LIBERA INTERNA A BAGNO D'OLIO • FLANGIA ATTACCO PER MOTOCOLTIVATORE • RULLO REGOLABILE • REVERSIBILE TIPO FRESA O FALCIATRICE • COLTELLI UNIVERSALI • PROTEZIONI ANTINFORTUNISTICHE A NORME CE

TECHNISCHE SERIENDATEN: TRINCIAERBA PER MOTOCOLTIVATORI • SCATOLA INGRANAGGI IN GHISA CON RUOTA LIBERA INTERNA A BAGNO D'OLIO • FLANGIA ATTACCO PER MOTOCOLTIVATORE • RULLO REGOLABILE • REVERSIBILE TIPO FRESA O FALCIATRICE • COLTELLI UNIVERSALI • PROTEZIONI ANTINFORTUNISTICHE A NORME CE

CARACTERÍSTICAS TÉCNICAS DE SERIE: TRINCIAERBA PER MOTOCOLTIVATORI • SCATOLA INGRANAGGI IN GHISA CON RUOTA LIBERA INTERNA A BAGNO D'OLIO • FLANGIA ATTACCO PER MOTOCOLTIVATORE • RULLO REGOLABILE • REVERSIBILE TIPO FRESA O FALCIATRICE • COLTELLI UNIVERSALI • PROTEZIONI ANTINFORTUNISTICHE A NORME CE



COLTELLI Y 405
KNIVES Y 405
COUTEAUX Y 405
MESSER Y 405
COUCHILLAS Y 405



MAZZE MF 1
HAMMER MF 1
FLEAUX MF 1
HAMMER MF 1
MAZAS MF 1

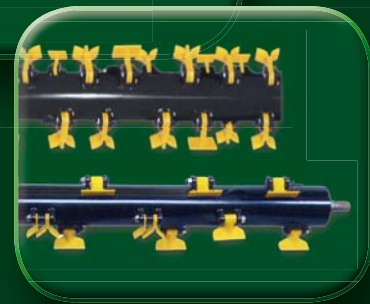

HBK										
	mm	Kw - HP	mm mm	n°	n°	n°	A	B	C	Kg
100	1000	10 - 12	500 330 500 670	56	28	2	295	1076	650	143
115	1150	12 - 14	575 330 575 820	64	32	2	295	1226	650	159
130	1300	12 - 14	650 330 650 970	72	36	2	295	1376	650	182

Un mondo di soluzioni

A lot of solutions - Un monde de solutions - Viele Lösungen - Un mónnton de solucíones

GRK

PROJET
AGRICULTURE



CARATTERISTICHE TECNICHE DI SERIE:

TRINCIATRICE ADATTA PER ERBA E PICCOLI SARMENTI MAX Ø CM 2 • MULTIPLICATORE CON RUOTA LIBERA INTERNA • SPOSTAMENTO MANUALE A 3 POSIZIONI • RULLO REGOLABILE Ø 140 • GIUNTO CARDANICO • BANDELLE PARASASSI • COPPIA SLITTE • PROTEZIONI ANTINFORTUNISTICHE A NORME CE

CURRENT TECHNICAL FEATURES:

SHREDDER SUITABLE FOR GRASS AND SMALL BRUSHWOOD MAX DIA. 2 CM • OVERGEAR WITH INSIDE FREE WHEEL • THREE-POSITION MANUAL MOVEMENT • ADJUSTABLE Ø 140 ROLLER • CARDAN SHAFT • STONEGUARD STRAPS • SLIDE PAIR • CE STANDARD ACCIDENT PREVENTION GUARD

CARACTERISTIQUES TECHNIQUES DE SERIE:

BROYEUR POUR HERBE ET PETITS SARMENTS DE 2 CM DE DIAMETRE MAXI • MULTIPLICATEUR A ROUTE LIBRE INTERNE • DISPOSITIF DE DÉPLACEMENT MANUEL À 3 POSITIONS • GALET REGLABLE Ø 140 • CARDAN • BANDE ANTI-PIERRES • COUPLE GLISSIERES • PROTECTIONS CONTRE LES ACCIDENTS DU TRAVAIL CONFORMES AUX NORMES CE

TECHNISCHE SERIENDATEN:

MULCHGERÄT FÜR GRAS UND KLEINE SCHÖSSLINGEN MAX. Ø CM 2 • ÜBERSETZUNGSGETRIEBE MIT INNEREM FREILAUF • MANUELLE 3-STELLEN-VERSCHIEBUNG • REGULIERBARE WALZE Ø 140 • KARDAN GELLENK • STEINSCHUTZBÄNDER • SCHLITTENPAAR • SCHUTZVORRICHTUNGEN, DIE DEN CE NORMEN ENTSPRECHEN

CARACTERÍSTICAS TÉCNICAS DE SERIE:

TRINCHADORA APTA PARA HIERBA Y PEQUEÑOS SARMIENTOS DE Ø 2 CM COMO MAX • MULTIPLICADOR CON RUEDA LIBRE INTERNA • DESPLAZAMIENTO MANUAL DE 3 POSICIONES • RODILLO REGULABLE Ø 140 • JUNTA CARDANICA • BANDAS PARAPIEDRAS • PAR DE PALAS DE ARRASTRE • PROTECCIONES CONTRA ACCIDENTES SEGUN NORMAS CE



COLTELLI Y 405

KNIVES Y 405

COUTEAUX Y 405

MESSER Y 405

COUCHILLAS Y 405



MAZZE MF 9

HAMMER MF 9

FLEAUX MF 9

HAMMER MF 9

MAZAS MF 9

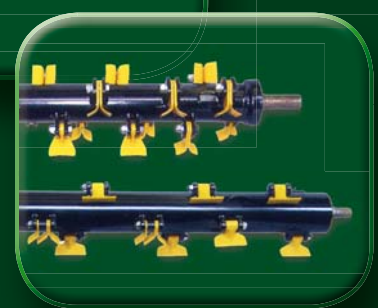

GRK	Tractor		Tractor		Y405I	MF9	Roller	Rpm	Dimensions			KG
	mm	Kw - HP	mm	mm					A	B	C	
115	1130	14 - 20	575 330	575 820	32+16	16	2	540	395	1203	700	193
130	1280	17 - 24	650 330	650 970	36+18	18	3	540	395	1380	700	200
140	1380	20 - 28	680 330	720 1070	40+20	20	3	540	395	1480	700	206
150	1480	22 - 30	680 330	820 1170	40+20	20	3	540	395	1580	700	213
160	1580	24 - 32	800 300	800 1300	44+22	22	3	540	395	1680	700	226

PROFESSIONAL LINE

SGK/S



-  COLTELLI Y 410
-  KNIVES Y 410
-  COUTEAUX Y 410
-  MESSER Y 410
-  COUCHILLAS Y 410



-  MAZZE MF 9
-  HAMMER MF 9
-  FLEAUX MF 9
-  HAMMER MF 9
-  MAZAS MF 9

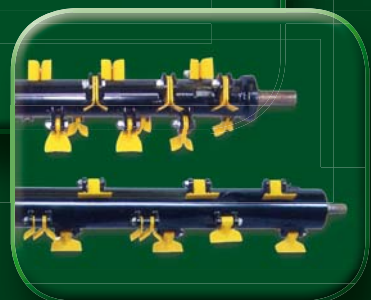













CARATTERISTICHE TECNICHE DI SERIE: TRINCIATRICE ADATTA PER ERBA, PICCOLI SARMENTI DI VIGNETO E FRUTTETO, MAX Ø 2/3 CM. • MOLTIPLICATORE CON RUOTA LIBERA INTERNA • SCOCCA CON DOPPIA STRUTTURA INTERNA • SPOSTAMENTO LATERALE A VITE SU BARRA CROMATA • RULLO REGOLABILE Ø 140 • GIUNTO CARDANICO • COFANO POSTERIORE APRIBILE CON CERNIERE PER ISPEZIONE E MANUTENZIONE • BANDELLE PARASASSI • CONTROCOLTELLO DENTATO • PROTEZIONI ANTINFORTUNISTICHE A NORME CE

CURRENT TECHNICAL FEATURES: SHREDDER SUITABLE FOR GRASS, SMALL BRUSHWOOD IN VINEYARDS AND ORCHARDS, MAX. Ø 2/3 CM. • OVERGEAR WITH INSIDE FREE WHEEL • BODY WITH DOUBLE INSIDE STRUCTURE • SCREW SIDE SHIFTING ON CHROMIUM • PLATED-TUBE • ADJUSTABLE Ø 140 ROLLER • CARDAN SHAFT • REAR HINGED HOOD FOR INSPECTION AND MAINTENANCE • STONEGUARD STRAPS • TOOTHED COUNTER • ACTING KNIFE • CE STANDARD ACCIDENT PREVENTION GUARD

CARACTERISTIQUES TECHNIQUES DE SERIE: HACHEUSE INDIQUEE POUR L'HERBE, LES PETITS SARMENTS DE VIGNE ET DE VERGER, Ø 2/3 CM MAX. • MOLTIPLICATEUR A ROUTE LIBRE INTERNE • COQUE AVEC DOUBLE STRUCTURE INTERNE • DEPLACEMENT LATERAL A VIS SUR TUBE CHROME • GALET REGLABLE Ø 140 • CARDAN • CARTER ARRIERE OUVRANT AVEC CHARNIERE POUR VISITE ET MAINTENANCE • BANDE ANTI-PIERRES • CONTRE-COUTEAU CRANTE • PROTECTIONS CONTRE LES ACCIDENTS DU TRAVAIL CONFORMES AUX NORMES CE

TECHNISCHE SERIENDATEN: SCHNEIDEMASCHINE FÜR GRAS, KLEINE REBLINGE UND OBSTBÄUME, MAX. Ø 2/3 CM. • ÜBERSETZUNGSGETRIEBE MIT INNEREM FREILAUF • KARROSSIERKÖRPER MIT INNERER DOPPELTEN STRUKTUR • SEITLICHES VERSCHIEBEN DURCH SCHRAUBEN AUF VERSCHROMTE BALKEN • KARDAN GELENK • AUFKLAHPBARE HINTERE HAUBE MIT SCHARNIEREN FÜR DIE INSPEKTION UND DIE WARTUNG • REGULIERBARE WALZE Ø 140 • STEINSCHUTZBÄNDER • GEZACKTE GEGENSCHNEIDE • SCHUTZVORRICHTUNGEN, DIE DEN CE NORMEN ENTSPRECHEN

CARACTERÍSTICAS TÉCNICAS DE SERIE: TRITURADORA IDONEA PARA HIERBA, PEQUEÑOS SARMIENTOS DE VIÑEDO Y PLANTACION DE FRUTAS, MAX. Ø 2/3 CM. • MULTIPLICADOR CON RUEDA LIBRE INTERNA • CARROCERIA CON DOBLE ESTRUCTURA INTERNA • DESPLAZAMIENTO LATERAL MEDIANTE TORNILLO SOBRE TUBO CROMADO • RODILO REGULABLE Ø 140 • JUNTA CARDANICA • COFRE TRASERO ABRIBLE CON BISAGRAS PARA INSPECCION Y MANTENIMIENTO • BANDAS PARAPIEDRAS • CONTRACUCHILLA DENTADA • PROTECCIONES CONTRA ACCIDENTES SEGUN NORMAS CEE

SGK/S												
	mm	Kw - HP	mm	mm	n°	n°	n°	Rpm	A	B	C	Kg
115	1130	15 - 20	575 350	575 775	16	32+16	3	540	950	1260	850	310
130	1280	21 - 30	650 350	650 950	18	36+18	3	540	950	1410	850	330
140	1380	21 - 30	750 350	700 1050	20	40+20	3	540	950	1510	850	338
150	1480	25 - 35	750 350	750 1150	20	40+20	3	540	950	1610	850	345
160	1580	25 - 35	800 350	800 1350	22	44+22	3	540	950	1710	850	358
175	1730	29 - 40	850 350	900 1400	24	48+24	3	540	950	1860	850	369

Un mondo di soluzioni

A lot of solutions - Un monde de solutions - Viele Lösungen - Un mónnton de soluciónes

SPK

PROJET
AGRICULTURE



COLTELLI Y 410
KNIVES Y 410
COUPEAUX Y 410
MESSER Y 410
COUCHILLAS Y 410



MAZZE MF 9
HAMMER MF 9
FLEAUX MF 9
HAMMER MF 9
MAZAS MF 9

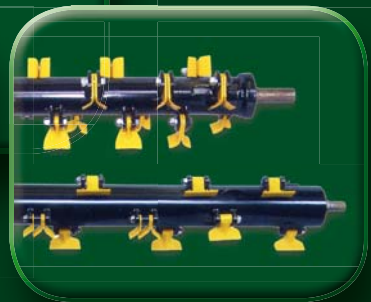

CARATTERISTICHE TECNICHE DI SERIE: TRINCIATRICE POLIVALENTE, ROBUSTA, CON COFANO APRIBILE, ADATTA PER LA LAVORAZIONE SU ERBA, SARMENTI, FRUTTETI, VIGNETI DA DIAMETRO 4 A 5 CM. • MULTIPLICATORE CON RUOTA LIBERA INTERNA • SCOCCA CON DOPPIA STRUTTURA INTERNA • GIUNTO CARDANICO • SPOSTAMENTO LATERALE A VITE SU TUBO CROMATO DAL MOD. 115 AL 200 • RULLO REGOLABILE DIAM. 170 • COFANO POSTERIORE APRIBILE CON CERNIERE PER ISPEZIONE E MANUTENZIONE • BANDELLE PARASASSI • CONTROCOLTELLO DENTATO

CURRENT TECHNICAL FEATURES: MULTIPURPOSE SHREDDER: STRONG, OPENABLE HOOD, SUITABLE FOR WORKING WITH GRASS, BRUSHWOOD, ORCHADS AND VINEYARDS (DIAMETER FROM 4 TO 5 CM). • OVERGEAR WITH INSIDE FREE WHEEL • BODY WITH DOUBLE INSIDE STRUCTURE • UNIVERSAL JOINT • SCREW SIDE SHIFT ON CHROMIUM-PLATED TUBE FROM MOD. 115 TO 200 • ADJUSTABLE 170 DIAM. ROLLER • REAR HINGED HOOD FOR INSPECTION AND MAINTENANCE • STONEGUARD STRAPS • TOOTHED COUNTER-ACTING KNIFE

CARACTERISTIQUES TECHNIQUES DE SERIE: HACHEUSE POLYVALENTE, ROBUSTE, AVEC CARTER OUVRANT, POUR LE HACHAGE DE L'HERBE, DES SARMENTES, DES VERGERS, DES VIGNOBLES DE 4 A 5 CM DE DIAMETRE. • MULTIPLICATEUR A ROUE LIBRE INTERNE • COQUE AVEC DOUBLE STRUCTURE INTERNE • CARDAN • DEPLACEMENT LATERAL A VIS SUR TUBE CHROME DU MOD. 115 AU MOD. 200 • GALET REGLABLE DIAMETRE 170 • CARTER ARRIERE OUVRANT AVEC CHARNIERE POUR VISITE ET MAINTENANCE • BANDE ANTI-PIERRES CONTRE-COUTEAU CRANTE

TECHNISCHE SERIENDATEN: DIE ROBUSTE MEHRZWECK-SCHNEIDMASCHINE MIT ABNEHMBARER Klappe IST FÜR DIE BEARBEITUNG VON GRAS, ZWEIFEN, OBSTGÄRTEN, WEINBERGE VON 4 BIS 5 CM DURCHMESSER. • ÜBERSETZUNGSGETRIEBE MIT INNEREM FREILAUF • KAROSSERIEKÖRPER MIT INNERER DOPPELTEN STRUKTUR • KARDANGELLENK • SEITLICHES VERSCHIEBEN DURCH SCHRAUBEN AUF VERCHROMTE ROHRE VON MODELL 115 BIS 200 • REGULIERBARE WALZE 170 Ø • AUFKLABBARE HINTERE HAUBE MIT SCHARNIEREN FÜR DIE INSPEKTION UND DIE WARTUNG • STEINSCHUTZBÄNDER • GEZACKTE GEGENSCHNEIDE

CARACTERÍSTICAS TÉCNICAS DE SERIE: TRINCHADORA POLIVALENTE, ROBUSTA, CON CAPÓ ABRIBILE, APTA PARA TRABAJAR CON HIERBA, SARMIENTOS, FRUTALES Y VIÑEDOS DE 4 A 5 CM DE DIÁMETRO. • MULTIPLICADOR CON RUEDA LIBRE INTERNA • CARROCERIA CON DOBLE ESTRUCTURA INTERNA • JUNTA CARDANICA • DESPLAZAMIENTO LATERAL MEDIANTE TORNILLO SOBRE TUBO CROMADO DEL MODELO 115 AL 200 • RODILLO REGULABLE DE 170 DE DIÁMETRO • COFRE TRASERO ABRIBILE CON BISAGRAS PARA INSPECCION Y MANTENIMIENTO • BANDAS PARAPIEDRAS • CONTRACUCHILLA DENTADA

SPK	mm		mm		MF 3	MF 4	Y410+M00	n°	Rpm	mm			KG
	mm	Kw - HP	mm	mm	n°	n°	n°			A	B	C	
115	1130	21 - 28	570	580	12	-	24+12	3	540	1015	1296	940	326
130	1290	21 - 30 25 - 35	650 400	650 900	12	-	24+12	4	540	1015	1430	1040	380
140	1390	21 - 30 25 - 35	700 400	700 1000	14	-	28+14	4	540	1015	1512	1040	400
150	1490	25 - 35 37 - 50	750 400	750 1100	16	-	32+16	4	540	1015	1630	1040	422
160	1590	29 - 40 44 - 60	800 400	800 1200	16	-	32+16	4	540	1015	1782	1040	440
175	1740	29 - 40 51 - 70	875 400	875 1350	16	-	32+16	4	540	1015	1880	1040	445
200	1990	33 - 45 59 - 80	1000 530	1000 1470	20	-	40+20	4	540	1015	2130	1040	510
230	2290	37 - 50 51 - 70	950 420	1350 1880	22	-	44+22	4	540	1015	2420	1040	630
260	2580	44 - 60 51 - 70	1300 800	1300 1800	-	24	48+24	5	540	1015	2720	1040	710
280	2780	44 - 60 51 - 70	1400 940	1400 1860	-	26	52+26	5	540	1015	2920	1040	775

PROFESSIONAL LINE

FRK



COLTELLI Y 410
KNIVES Y 410
COUTEAUX Y 410
MESSER Y 410
COUCHILLAS Y 410

MAZZE MF 9
HAMMER MF 9
FLEAUX MF 9
HAMMER MF 9
MAZAS MF 9

CARATTERISTICHE TECNICHE DI SERIE: TRINCIATRICE PER TRATTORI REVERSIBILI ADATTA PER LA LAVORAZIONE DI SARMENTI Ø CM 3+5 ED ERBA IN FRUTTETI, VIGNETI, ACTINIDIA (KIWI) • MOLTIPLICATORE CON RUOTA LIBERA INTERNA • SCOCCA CON DOPPIA STRUTTURA INTERNA • GIUNTO CARDANICO • RULLO REGOLABILE Ø 170 • BANDELLA PARASASSI • SPOSTAMENTO LATERALE A VITE SU TUBO CROMATO

CURRENT TECHNICAL FEATURES: SHREDDER FOR REVERSIBLE TRACTORS SUITABLE FOR WORKING WITH Ø CM 3+5 BRUSHWOOD AND GRASS IN ORCHARDS, VINEYARDS AND KIWI • OVERGEAR WITH INSIDE FREE WHEEL • BODY WITH DOUBLE INSIDE STRUCTURE • UNIVERSAL JOINT • ADJUSTABLE 170 Ø ROLLER • STONE-GUARD STRAPS • SCREW SIDE SHIFT ON CHROMIUM-PLATED TUBE

CARACTERISTIQUES TECHNIQUES DE SERIE: BROYEUR POUR TRACTEURS RÉVERSIBLES POUR LE HACHAGE DES SARMENTS Ø CM 3+5 ET HERBE DANS VERGERS, VIGNOBLES, SUR ARBRE DU KIWI • MULTIPLICATEUR A ROUE LIBRE INTERNE • COQUE AVEC DOUBLE STRUCTURE INTERNE • CARDAN • GALET REGLABLE Ø 170 • BANDE ANTI-PIERRES • DEPLACEMENT LATERAL A VIS SUR TUBE CHROME

TECHNISCHE SERIENDATEN: SCHNEIDEMASCHINE FÜR UMSCHALTBARE TRAKTOREN FÜR DIE BEARBEITUNG VON ZWEIGEN Ø CM 3+5 UND GRAS, OBST- UND WEINGÄRTEN, KIWIPFLANZGÄRTEN • ÜBERSETZUNGSGETRIEBE MIT INNEREM FREILAUF • KAROSSERIEKÖRPER MIT INNERER DOPPELTEN STRUKTUR • KARDANGELENK • REGULIERBARE WALZE 170 Ø • STEINSCHUTZBÄNDER • SEITLICHES VERSCHIEBEN DURCH SCHRAUBEN AUF VERCHROMTE ROHRE

CARACTERÍSTICAS TÉCNICAS DE SERIE: SACHADORA PARA TRACTORES REVERSÍVEIS ADEQUADA PARA TRABAJO DE SARMENTOS Ø CM 3 + 5 E RELVADO EM POMARES, VINHAS, ACTINÍDIOS (KIWI) • MULTIPLICADOR DE RODA LIVRE INTERNA • INVÓLUCRO COM DUPLA ESTRUTURA INTERIOR • UNIÃO DE CARDAN • ROLO REGULÁVEL Ø 170 • FAIXAS DE PROTECÇÃO CONTRA PEDRAS • DESLOCAMENTO LATERAL MEDIANTE PARAFUSO EM TUBO CROMADO

FRK										
	mm	HP (min-max)	mm mm	n°	n°	n°	Rpm	A B C	Kg	
130	1280	35-65	650 650 420 880	12	24 + 12	4	540	1000 1450 1100	415	
150	1480	35-65	750 750 420 1080	16	32 + 16	4	540	1000 1650 1100	450	
175	1730	40-75	840 910 420 1330	18	36 + 18	4	540	1000 1900 1100	485	
200	1980	40-75	980 1020 480 1520	20	40 + 20	4	540	1000 2150 1100	520	
230	2280	60-90	980 1320 480 1820	22	44 + 22	4	540	1000 2450 1100	630	

Un mondo di soluzioni

A lot of solutions - Un monde de solutions - Viele Lösungen - Un mónnton de soluciónes

FRKR

PROJET

AGRICULTURE



- COLTELLI Y 410
- KNIVES Y 410
- COUTEAUX Y 410
- MESSER Y 410
- COUCHILLAS Y 410



- MAZZE MF 3
- HAMMER MF 3
- FLEAUX MF 3
- HAMMER MF 3
- MAZAS MF 3

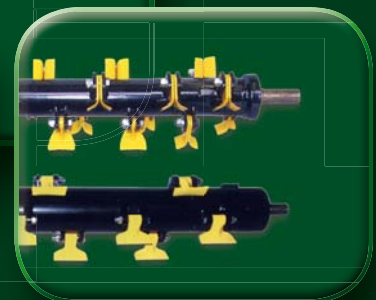

CARATTERISTICHE TECNICHE DI SERIE: TRINCIATRICE REVERSIBILE ANTERIORE O FRONTALE ADATTA PER LA LAVORAZIONE DI SARMENTI Ø CM 3+5 ED ERBA IN FRUTTETI, VIGNETI, ACTINIDIA (KIWI) • GRUPPO MOLTIPLICATORE CON CAMBIO REVERSIBILE A DOPPIA RUOTA LIBERA INTERNA • TERZO PUNTO CON DOPPIO ATTACCO • SCOCCA CON DOPPIA STRUTTURA INTERNA • GIUNTO CARDANICO • SPOSTAMENTO LATERALE A VITE SU TUBO CROMATO • RULLO REGOLABILE Ø 170 • BANDELLE PARASASSI

TECHNISCHE SERIENDATEN: UMSCHALTBARE VORDER- ODER FRONTSCHNEIDEMASCHINE FÜR DIE BEARBEITUNG VON ZWEIGEN Ø CM 3+5 UND GRAS, IN OBST- UND WEINGÄRTEN, KIWIPFLANTAGEN • ÜBERSETZERGRUPPE MIT UMKEHRSCHALTUNG UND MIT INNEREM DOPPELTEM FREILAUF • DRITTER HALTEPUNKT MIT DOPPELTER KUPPLUNG • KAROSSERIEKÖRPER MIT INNERER DOPPELT VERGRÖßERTEN STRUKTUR • KARDANGELN • SEITLICHES VERSCHIEBEN DURCH SCHRAUBEN AUF VERCHROMTE ROHRE • REGULIERBARE WALZE 170 Ø • SEITLICHES VERSCHIEBEN DURCH SCHRAUBEN

CARACTERÍSTICAS TÉCNICAS DE SERIE: TRINCHADORA REVERSIBLE TRASERA O FRONTAL PARA TRABAJAR CON SARMIENTOS Ø CM 3 + 5 Y HIERBA EN FRUTALES, VIÑEDOS Y PLANTACIONES DE ACTINIDIA (KIWI) • GRUPO MULTIPLICADOR CON CAMBIO REVERSIBLE CON DOBLE RUEDA LIBRE INTERNA • TERCER PUNTO CON DOBLE ENGANCHE • CARROCERIA CON DOBLE ESTRUCTURA INTERNA • JUNTA CARDANICA • DESPLAZAMIENTO LATERAL MEDIANTE TORNILLO SOBRE TUBO CROMADO • RODILLO REGULABLE Ø 170 • BANDAS PARAPIEDAS

CURRENT TECHNICAL FEATURES: FRONT REVERSIBLE SHREDDER SUITABLE FOR WORKING WITH Ø CM 3+5 BRUSHWOOD AND GRASS IN ORCHARDS, VINEYARDS AND KIWI • OVERGEAR UNIT WITH REVERSE GEAR WITH DOUBLE INSIDE FREE WHEEL • THIRD POINT WITH DOUBLE COUPLING • BODY WITH REINFORCED INSIDE DOUBLE STRUCTURE • UNIVERSAL JOINT • SCREW SIDE SHIFT ON CHROMIUM-PLATED TUBE • ADJUSTABLE 170 Ø ROLLER • STONEGUARD STRAPS

CARACTERISTIQUES TECHNIQUES DE SERIE: BROYEUR RÉVERSIBLE AVANT OU FRONTAL POUR LE HACHAGE DES SARMENTS DE 3+5 CM Ø ET HERBE DANS LES VERGERS, LES VIGNOBLES, LES ACTINIDIAS (KIWIS) • GROUPE MULTIPLICATEUR AVEC CHANGEMENT REVERSIBLE A DOUBLE ROUE LIBRE INTERNE • TROISIEME POINT AVEC DOUBLE RACCORD • COQUE AVEC DOUBLE STRUCTURE INTERNE • CARDAN • DEPLACEMENT LATERAL A VIS SUR TUBE CHROME • GALET REGLABLE Ø 170 • BANDE INTI-PIERRES

FRKR												
								A	B	C		
	mm	HP (min-max)	mm mm	MF3 n°	Y410 + I408 n°	n°	Rpm	A	B	C	Kg	
130	1280	40-75	650 650 420 880	12	24 + 12	4	540	1000	1450	1100	475	
150	1480	40-75	750 750 420 1080	16	32 + 16	4	540	1000	1650	1100	508	
175	1730	50-80	840 910 420 1330	18	36 + 18	4	540	1000	1900	1100	545	
200	1980	50-80	980 1020 480 1520	20	40 + 20	4	540	1000	2150	1100	575	
230	2280	60-90	980 1320 480 1820	22	44 + 22	4	540	1000	2450	1100	620	

PROFESSIONAL LINE

MTK

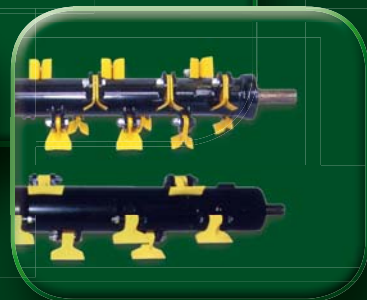

- COLTELLI Y 410**
- KNIVES Y 410**
- COUTEAUX Y 410**
- MESSER Y 410**
- COUCHILLAS Y 410**

- MAZZE MF 3**
- HAMMER MF 3**
- FLEAUX MF 3**
- HAMMER MF 3**
- MAZAS MF 3**

- MAZZE MF 4**
- HAMMER MF 4**
- FLEAUX MF 4**
- HAMMER MF 4**
- MAZAS MF 4**

CARATTERISTICHE TECNICHE DI SERIE: TRINCIATRICE POLIVALENTE ROBUSTA CON COFANO APRIBILE PER LA LAVORAZIONE DI SARMENTI Ø CM 6-8, MAIS, PAGLIA, SORGO, ERBA, FRUTTETI E VIGNETI: MOLTIPLICATORE CON RUOTA LIBERA INTERNA • SCOCCA CON DOPPIA STRUTTURA INTERNA • GIUNTO CARDANICO • RULLO REGOLABILE Ø 170 • BANDELLE PARASASSI • SPOSTAMENTO A VITE • COFANO POSTERIORE APRIBILE PER ISPEZIONE E MANUTENZIONE • CONTROCOLTELLO DENTATO

TECHNISCHE SERIENDATEN: DIE ROBUSTE MEHRZWECK-SCHNEIDEMASCHINE MIT ABNEHMBARE HINTERE KLASPE EIGNET SICH FÜR DIE BEARBEITUNG VON ZWEIGEN Ø CM 6-8, MAIS, STROH, HIRSE, GRAS, OBST- UND WEINGÄRTEN: ÜBERSETZUNGSGETRIEBE MIT INNEREM FREILAUF • KAROSSERIEKÖRPER MIT INNERER DOPPELTEN STRUKTUR • KARDANGELENK • REGULIERBARE WALZE 170 Δ • STEINSCHUTZBÄNDER • SCHRAUBENVERSCHIEBUNG • AUFKLAPPBARE HINTERE FÜR DIE INSPEKTION UND DIE WARTUNG • GEZACKTE GEGENSCHNEIDE

CARACTERÍSTICAS TÉCNICAS DE SERIE: TRINCHADORA POLIVALENTE, ROBUSTA, CON CAPO ABRILE, APTA PARA TRABAJAR CON SARMIENTOS Ø CM 6-8, MAIZ, PAJA, SORGO, HIERBA, EN FRUTALES Y VIÑEDOS • MULTIPLICADOR CON RUEDA LIBRE INTERNA • CARROCERIA CON DOBLE ESTRUCTURA INTERNA • JUNTA CARDANICA • RODILLO REGULABLE DE 170 DE DIAMETRO • BANDAS TORNIJAS • DESPLAZAMIENTO MEDIANTE TORNILLO • COFRE TRASERO ABRIBLE PARA INSPECCION Y MANTENIMIENTO • CONTRACUCHILLA DENTADA

CURRENT TECHNICAL FEATURES: STRONG MULTIPURPOSE SHREDDER. OPENABLE HOOD. SUITABLE FOR WORKING WITH Ø CM 6-8 BRUSHWOOD, MAIZE, STRAW, SORGHUM, GRASS, IN ORCHARDS AND VINEYARDS: OVERGEAR WITH INSIDE FREE WHEEL • BODY WITH DOUBLE INSIDE STRUCTURE • UNIVERSAL JOINT • ADJUSTABLE 170 DIAM. ROLLER • STONEGUARD STRAPS • SCREW SIDE SHIFT • REAR HINGED HOOD FOR INSPECTION AND MAINTENANCE • TOOTHED COUNTER-ACTING KNIFE

CARACTERISTIQUES TECHNIQUES DE SERIE: HACHEUSE POLYVALENTE, ROBUSTE, AVEC CARTER OUVRANT, POUR LE HACHAGE DU SARMENTS Ø CM 6-8, DU MAÏS, DE LA PAILLE, DU SORGHO, DE L'HERBE, SUR TERRAINS EN JACHERE ET DANS VERGERS, VIGNOBLES: MULTIPLICATEUR A ROUE LIBRE INTERNE • COQUE AVEC DOUBLE STRUCTURE INTERNE • CARDAN • GALET REGLABLE DIAMETRE 170 • BANDE ANTIPIERRES • DEPLACEMENT A VIS • CARTER ARRIERE OUVRANT POUR VISITE ET MAINTENANCE • CONTRE-COUTEAU CRANTE

MTK	mm		mm		n°			n°		Rpm	A B C			Kg	
	mm	Kw - HP	mm	mm	MF2	MF3	MF4	Y505	Y410+408		A	B	C		
150	1480	25-35 37-50	750 400	750 1050	16	-	-	32	-	4	540	430	1650	1050	500
160	1580	39-40 51-70	800 450	800 1150	16	-	-	32	-	4	540	430	1750	1050	520
175	1730	33-45 51-70	870 450	880 1300	18	-	-	36	-	4	540	430	1900	1050	550
200	1980	44-60 51-70	950 450	1050 1550	20	-	-	40	-	4	540	430	2150	1050	600
230	2280	51-70 59-80	1150 675	1150 1625	-	22	-	-	44+22	4	540	430	2450	1050	680
260	2580	59-70 64-90	1175 675	1475 1925	-	-	24	-	48+24	5	540	430	2750	1050	825
280	2780	51-70 71-100	1400 1055	1400 1745	-	-	26	-	52+26	5	540	430	2930	1050	895

Un mondo di soluzioni

A lot of solutions - Un monde de solutions - Viele Lösungen - Un món ton de solució nes

BTK

PROJET
AGRICULTURE

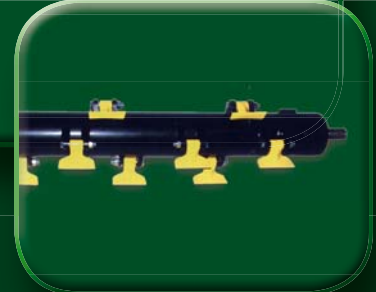
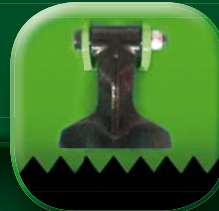

CARATTERISTICHE TECNICHE DI SERIE:
TRINCIATRICE SEMIFORESTALE MOLTO ROBUSTA E AFFIDABILE, ADATTA PER LAVORI GRAVOSI SU SARMENTI DI GROSSO DIAMETRO DA CM 10÷15 IN ULIVETI, AGRUMETI, FRUTTETI • MULTIPLICATORE CON RUOTA LIBERA INTERNA • SCOCCA CON DOPPIA STRUTTURA INTERNA MAGGIORATA • GIUNTO CARDANICO • SPOSTAMENTO LATERALE A VITE SU TUBO CROMATO • RULLO REGOLABILE Ø 170 • CATENE PARASASSI • BANDELLE PARASASSI • TRE FILE DI CONTROCOLTELLI

TECHNISCHE SERIENDATEN: DIE SEHR ROBUSTE UND ZUVERLÄSSIGE WALDSCHNEIDEMASCHINE EIGNET SICH FÜR SCHWERE ARBEITEN IN OLIVENHAINEN, ZITRUSGÄRTEN, OBSTGÄRTEN FÜR SCHNEIDEN VON CM 10÷15 Ø • ÜBERSETZUNGSGETRIEBE MIT INNEREM FREILAUF • KAROSSERIEKÖRPER MIT INNERER DOPPELT VERGRÖßERTEN STRUKTUR • KARDANGELN • SEITLICHES VERSCHIEBEN DURCH SCHRAUBEN (AUF VERCHROMTE ROHRE) • REGULIERBARE WALZE 170 Ø • STEINSCHUTZKETTE • SEITLICHES VERSCHIEBEN DURCH SCHRAUBEN • DREI REIHEN VON GEGENSCHNEIDERN

CARACTERÍSTICAS TÉCNICAS DE SERIE:
TRINCHADORA SEMIFORESTAL MUY ROBUSTA Y FIABLE, IDONEA PARA TRABAJOS DIFÍCILES SOBRE SARMIENTOS DE OLIVARES, PLANTACIONES DE CITRICOS, PLANTACIONES DE FRUTALES PARA SARMIENTOS DE GRANDE DIAMETRO DE CM 10÷15 • MULTIPLICADOR CON RUEDA LIBRE INTERNA • CARROCERIA CON DOBLE ESTRUCTURA INTERNA AUMENTADA • JUNTA CARDANICA • DESPLAZAMIENTO LATERAL MEDIANTE TORNILLO (SOBRE TUBO CROMADO) • RODILLO REGULABLE Ø 170 • CADENA PARAPIEDRAS • BANDAS PARAPIEDRAS • TRES FILAS DE CONTRACUCHILLAS

MAZZE MF 5
HAMMER MF 5
FLEAUX MF 5
HAMMER MF 5
MAZAS MF 5

CURRENT TECHNICAL FEATURES: SEMI-FOREST SHREDDER. VERY STRONG AND RELIABLE, SUITABLE FOR HEAVY DUTY ON OLIVE BRANCHES, CITRUS, ORCHARDS FOR LARGE BRANCHES UP TO CM 10÷15 • OVERGEAR WITH INSIDE FREE WHEEL • BODY WITH REINFORCED INSIDE DOUBLE STRUCTURE • UNIVERSAL JOINT • SCREW SIDE SHIFT (ON CHROMIUM-PLATED TUBE) • ADJUSTABLE Ø 170 ROLLER • STONEGUARD CHAIN • STONEGUARD STRAPS • THREE RANGES OF COUNTER-ACTING KNIVES

CARACTERISTIQUES TECHNIQUES DE SERIE:
HACHEUSE POUR APPLICATION DEMI-FORESTIERE, TRES ROBUSTE ET TRES FIABLE, POUR DES HACHAGES DIFFICILES SUR SARMENTS D'OLIVIERS, AGRUMES, ARBRES FRUITIERS, POUR DES BRANCHES DE GROS DIAMETRE, DE CM 10÷15 • MULTIPLICATEUR A ROUE LIBRE INTERNE • COQUE AVEC DOUBLE STRUCTURE INTERNE MAJOREE • CARDAN • DEPLACEMENT LATERAL A VIS (SUR TUBE CHROME) • GALET REGLABLE Ø 170 • CHAINE ANTI-PIERRES • BANDE ANTI-PIERRES • TROIS RANGEES DE CONTRE-COUTEAUX

BTK											
	mm	Kw - HP	mm mm	MF 5 n°	n°	Rpm	A	B	C	Kg	
150	1480	44 - 60	750 750 500 1000	12	4	540	610	1650	1200	680	
175	1730	59 - 80	870 880 500 1250	12	5	540	610	1900	1200	745	
200	1980	64 - 90	1000 1000 500 1500	16	5	540	610	2150	1200	835	

PROFESSIONAL LINE

BTKR

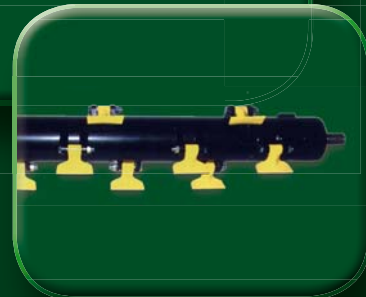
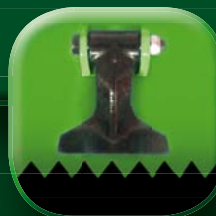

- MAZZE MF 5
- HAMMER MF 5
- FLEAUX MF 5
- HAMMER MF 5
- MAZAS MF 5

CARATTERISTICHE TECNICHE DI SERIE:

TRINCIATRICE REVERSIBILE SEMIFORESTALE MOLTO ROBUSTA E AFFIDABILE, ADATTA PER LAVORI GRAVOSI SU SARMENTI DI ULIVETI, AGRUMETI, FRUTTETI PER SARMENTI DI GROSSO DIAMETRO DA CM 10÷15 • GRUPPO MOLTIPLICATORE CON CAMBIO REVERSIBILE A DOPPIA RUOTA LIBERA INTERNA • TERZO PUNTO CON DOPPIO ATTACCO • SCOCCA CON DOPPIA STRUTTURA INTERNA MAGGIORATA • GIUNTO CARDANICO • SPOSTAMENTO LATERALE A VITE SU TUBO CROMATO • RULLO REGOLABILE Ø 170 • CATENE PARASASSI • BANDELLE PARASASSI • TRE FILE DI CONTROCOLTELLI

TECHNISCHE SERIENDATEN:

DIE UMSCHALTBAR SEHR ROBUSTE UND ZUVERLÄSSIGE WALDSCHNEIDEMASCHINE EIGNET SICH FÜR SCHWERE ARBEITEN IN OLIVENHAINEN, ZITRUSGÄRTEN, OBSTGÄRTEN FÜR SCHNEIDEN VON CM 10÷15 Ø • ÜBERSETZERGRUPPE MIT UMKEHRSCALTUNG UND MIT INNEREM DOPPELTEM FREILAUF • DRITTER HALTEPUNKT MIT DOPPELTER KUPPLUNG • KAROSSEKÖRPER MIT INNERER DOPPELT VERGRÖßERTEN STRUKTUR • KARDANGELNCK • SEITLICHES VERSCHIEBEN DURCH SCHRAUBEN (AUF VERCHROMTE ROHRE) • REGULIERBARE WALZE 170 Ø • STEINSCHUTZKETTE • STEINSCHUTZBÄNDER • DREI REIHEN VON ÜBERSCHNEIDUNGSMESSER

CARACTERÍSTICAS TÉCNICAS DE SERIE:

TRINCHADORA REVERSIBLE SEMIFORESTAL MUY ROBUSTA Y FIABLE, IDONEA PARA TRABAJOS DIFÍCILES SOBRE SARMIENTOS DE OLIVARES, PLANTACIONES DE CITRICOS, PLANTACIONES DE FRUTALES PARA SARMIENTOS DE GRANDE DIAMETRO DE CM 10÷15 • GRUPO MULTIPLICADOR CON CAMBIO REVERSIBLE CON DOBLE RUEDA LIBRE INTERNA • TERCER PUNTO CON DOBLE ENGANCHE • CARROCERIA CON DOBLE ESTRUCTURA INTERNA • JUNTA CARDANICA • DESPLAZAMIENTO LATERAL MEDIANTE TORNILLO (SOBRE TUBO CROMADO) • RODILLO REGULABLE Ø 170 • CADENA PARAPIEDRAS • BANDAS PARAPIEDRAS • TRES FILAS DE CONTRACUCHILLAS

CURRENT TECHNICAL FEATURES:

REVERSIBLE SEMI-Forest SHREDDER. VERY STRONG AND RELIABLE. SUITABLE FOR HEAVY DUTY ON OLIVE BRANCHES, CITRUS, ORCHARDS FOR LARGE BRANCHES UP TO CM 10÷15 • OVERGEAR UNIT WITH REVERSE GEAR WITH DOUBLE INSIDE FREE WHEEL • THIRD POINT WITH DOUBLE COUPLING • BODY WITH REINFORCED INSIDE DOUBLE STRUCTURE • UNIVERSAL JOINT • SCREW SIDE SHIFT (ON CHROMIUM-PLATED TUBE) • ADJUSTABLE Ø 170 ROLLER • STONEGUARD CHAIN • STONEGUARD STRAPS • THREE RANGES OF COUNTER-ACTING KNIVES

CARACTERISTIQUES TECHNIQUES DE SERIE:

HACHEUSE POUR APPLICATION DEMIFORESTIERE, TRES ROBUSTE ET TRES FIABLE, POUR DES HACHAGES DIFFICILES SUR SARMENTS D'OLIVIERS, AGRUMES, ARBRES FRUITIERS, POUR DES BRANCHES DE GROS DIAMETRE, DE CM 10÷15 • GROUPE MULTIPLICATEUR AVEC CHANGEMENT REVERSIBLE A DOUBLE ROUE LIBRE INTERNE • TROISIEME POINT AVEC DOUBLE RACCORD • COQUE AVEC DOUBLE STRUCTURE INTERNE • CARDAN • DEPLACEMENT LATERAL A VIS (SUR TUBE CHROME) • GALET REGLABLE Ø 170 • CHAÎNE ANTI-PIERRES • BANDE ANTIPIERRES • TROIS RANGÉES DE CONTRE-COUTEAUX

BTKR											
	mm	Kw - HP	mm	mm	n°	n°	Rpm	A	B	C	Kg
150	1480	44 - 60	750 500	750 1000	12	4	540	610	1650	1200	770
175	1730	59 - 80	870 500	880 1250	12	5	540	610	1900	1200	865
200	1980	64 - 90	1000 500	1000 1500	16	5	540	610	2150	1200	950

Un mondo di soluzioni

A lot of solutions - Un monde de solutions - Viele Lösungen - Un món ton de solució nes

VGK

PROJET
AGRICULTURE



-  MAZZE MF 3
-  HAMMER MF 3
-  FLEAUX MF 3
-  HAMMER MF 3
-  MAZAS MF 3









CURRENT TECHNICAL FEATURES: VERY ROBUST AND COMPACT SHREDDER. IT CAN SHRED SARMENTS IN VINEYARDS AND ORCHARDS ON STONY, WET OR SANDY SOIL. • OVERDRIVE WITH INTERNAL FREEWHEEL • MECHANICAL PICK-UP TRANSMISSION • AUTOMATIC LIMITER • THREE RANKS OF COUNTER-ACTING KNIVES • HINGED HOOD FOR INSPECTION AND MAINTENANCE • REAR STEERING WHEELS • CONVEYOR • UNIVERSAL JOINT

CARACTERISTIQUES TECHNIQUES DE SERIE: BROYEUSE TRES ROBUSTE ET COMPACTE. ELLE PERMET LE BROYAGE DE SARMENTS D'UN DIAMETRE DE SUR DES VIGNES, DES VERGERS, DES TERRAINS PIERREUX, MOUILLES OU SABLEUX. • MULTIPLICATEUR AVEC ROUE LIBRE INTERNE • TRANSMISSION RAMASSEUR MECANIQUE • LIMITEUR AUTOMATIQUE • TROIS RANGES DE CONTRE-COUTEAUX • CARTER OUVRANT POUR VISITE ET MAINTENANCE • ROUES ARRIERE DIRECTRICES • CONVOYEUR • CARDAN

CARATTERISTICHE TECNICHE DI SERIE: TRINCIATRICE MOLTO RUBUSTA E COMPATTA. PERMETTE DI TRINCIARE SARMENTI SU VIGNETI E FRUTTETI, IN TERRENI SASSOSI BAGNATI, O SABBIOSI. • MOLTIPLICATORE CON RUOTA LIBERA INTERNA • TRASMISSIONE PICKUP MECCANICO • LIMITATORE AUTOMATICO • 3 FILE DI CONTROCOLTELLI • COFANO APRIBILE PER ISPEZIONE E MANUTENZIONE • RUOTE POSTERIORI STERZANTI • CONVOGLIATORI • CARDANO

TECHNISCHE SERIENDATEN: MULCHGERÄT SEHR ROBUSTE UND KOMPACTE MASCHINE, MIT DER SCHÖSLINGE DURCHMESSER IN WEIN- UND OBSTGÄRTEN BEI STEINIGEM, NASSEM ODER SANDIGEM BODEN GEMULCHT WERDEN KÖNNEN. • ÜBERSETZUNGSGETRIEBE MIT FREILAUF • MECHANISCHER PICK-UP-ANTRIEB • AUTOMATISCHER BEGRENZER • DREI REIHEN VON ÜBERSCHNEIDUNGSMESSER • AUFKLAPPBARE HINTERE HAUBE FÜR DIE INSPEKTION UND DIE WARTUNG • HINTERE LENKRÄDER • FÖRDERWERK • KARDANGELLENK

CARACTERÍSTICAS TÉCNICAS DE SERIE: TRINCHADORA ROBUSTA Y COMPACTA. PERMITE TRINCHAR SARMIENTOS EN VIÑEDOS Y FRUTALES, EN TERRENOS PEDREGOSOS HUMEDOS O ARENOSOS. • MULTIPLICADOR CON RUEDA LIBRE INTERNA • TRANSMISION PICK-UP MECANICO • LIMITADOR AUTOMATICO • TRES FILAS DE CONTRACUCHILLAS • COFRE ABRIBLE PARA INSPECCION Y MANTENIMIENTO • RUEDAS TRASERAS DIRECTRICES • ENDEREZADOR • CARDAN

VGK									
	mm	Kw - HP	n°	n°	Rpm	A	B	C	Kg
95	930	29 - 40	8	3	540	770	1102	1150	520
115	1110	29 - 40	12	3	540	770	1306	1150	600
130	1260	37 - 50	12	3	540	770	1500	1150	670
150	1460	44 - 60	16	3	540	770	1700	1150	750
175	1720	51 - 70	18	3	540	770	1946	1150	865

PROFESSIONAL LINE

BLK

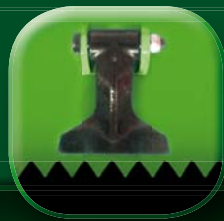

MAZZE MF 5

HAMMER MF 5

FLEAUX MF 5

HAMMER MF 5

MAZAS MF 5

CURRENT TECHNICAL FEATURES: SHREDDER SUITABLE FOR CUTTING GRASS, TRITURATION REEDS, SHRUBS UP TO Ø 6-8 CM ON ROAD SIDES, BANKS AND DITCHES • EXTERNAL GEAR BOX GROUP WITH FREE WHEELFRAME WITH DOUBLE INTERNAL STRUCTURE • HYDRAULIC SWING ARM WITH LATERAL MOVEMENT SELF HEAD HYDRAULIC ANGLE • ADJUSTABLE ROLL Ø 170 • BACK COVER INSPECTION • STONEGUARD RUBBERS • LEVELING BRACKET SIDE TRACTOR • CARDAN

CARACTERISTIQUES TECHNIQUES DE SERIE: BROYEUR TRÈS SOLIDE POUR DES HACHAGES DIFFICILES SUR RÉSIDUS DE TAILLE DE 10-15 CM DE Ø DANS LES OLIVERAIES, LES PLANTATIONS D'AGRUMES, LES VERGERS • MULTIPLICATEUR AVEC GALET FOU INTERNE • DOUBLE RAMASSEUR À ROTATION INVERSE AVEC TRANSMISSION HYDRAULIQUE • COQUE AVEC DOUBLE STRUCTURE INTERNE MAJORÉE • 2 RANGÉES DE CONTRE-COUTEAUX • CARTER DE VISITE ARRIÈRE • ROUES FIXES • AILERONS • CARDAN

CARATTERISTICHE TECNICHE DI SERIE: TRINCIATRICE MOLTO ROBUSTA ADATTA PER LAVORI GRAVOSI SU RESIDUI DI POTATURA Ø 10-15 CM IN ULIVETI, AGRUMETI, FRUTTETI • MULTIPLICATORE CON RUOTA LIBERA INTERNA • DOPPIO PICK-UP CONTROROTANTE CON TRASMISSIONE IDRAULICA • SCOCCA CON DOPPIA STRUTTURA INTERNA MAGGIORATA • 2 FILE CONTROCOLTELLI • COFANO D'ISPEZIONE POSTERIORE • RUOTE FISSE • CONVOGLIATORI • CARDANO

TECHNISCHE SERIENDATEN: SEHR ROBUSTE SCHNEIDEMASCHINE EIGNET SICH FÜR SCHWERE ARBEITEN WIE AUSSCHNEIDEN VON ZWEIGEN Ø CM 10-15, IN OLIVENHAINEN, AGRUMENPFLANZUNGEN, OBSTGÄRTEN • ÜBERSETZUNGSGETRIEBE MIT INNEREM FREILAUF • GEGENLAUFENDER DOPPELPICK-UP-AUFZUG MIT DRUCKÖLGETRIEBE • KAROSSERIEKÖRPER MIT INNERER VERSTÄRKTER DOPPELSTRUKTUR • 2 REIHEN VON GEGENSCHNEIDEN • AUFKLABBARE HINTERE HAUBE FÜR DIE INSPEKTION • FESTE RÄDER • FÖRDERER • KARDANGELENK

CARACTERÍSTICAS TÉCNICAS DE SERIE: TRINCHADORA MUY ROBUSTA IDONEA PARA TRABAJOS PESADOS EN RESIDUOS DE PODA Ø 10-15 CM EN PLANTACIONES DE OLIVOS, DE AGRIOS, FRUTALES • MULTIPLICADOR CON RUEDA LIBRE INTERNA • RECOGEDOR DOBLE CONTRAROTATORIO CON TRANSMISION HIDRAULICA • BASTIDOR CON ESTRUCTURA DOBLE INTERNA SOBREDIMENSIONADA • 2 HILERAS CONTRACUCHILLAS • COFRE DE INSPECCION TRASERO • RUEDAS FIJAS • TRANSPORTADORES • CARDAN

BLK										
	mm	HP (min-max)	n° MF 5	n°	Rpm	A	B	C	Kg	
175	1730	90 - 120	12	5	540	1600	2050	1300	1100	
200	1980	90 - 140	16	5	540	1600	2300	1300	1270	

Un mondo di soluzioni

A lot of solutions - Un monde de solutions - Viele Lösungen - Un mónton de solucióes

TCB

PROJET
AGRICULTURE

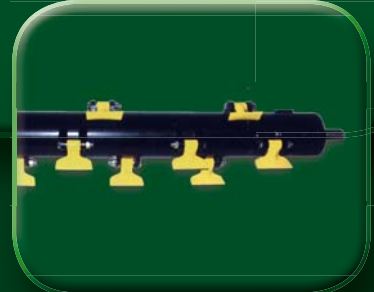

-  MAZZE MF 3
-  HAMMER MF 3
-  FLEAUX MF 3
-  HAMMER MF 3
-  MAZAS MF 3

IT CARATTERISTICHE TECNICHE DI SERIE: TRINCIATRICE POLIVALENTE CON RACCOGLITORE BASSO, ADATTA PER LA LAVORAZIONE SU ERBA SARMENTI, FRUTTETI, VIGNETI DI MEDIE DIMENSIONI DIAM. 7-8 CM • RULLO POSTERIORE REGOLABILE DIAM. 220 • TENDICINGHIA AUTOMATICO E SISTEMA DI INGRASSAGGIO CENTRALIZZATO • CAPACITA' CESTELLO DA 1,20 A 1,60 (M3) • APERTURA IDRAULICA CESTELLO • BANDELLE PARASASSI • CARDANO

UK CURRENT TECHNICAL FEATURES: VERSATILE SHREDDER WITH LOW COLLECTOR, SUITABLE FOR WORKING ON GRASS, WOODS, ORCHARDS, VINEYARDS, MEDIUM-SIZED DIA. 7-8 cm • ADJUSTABLE REAR ROLLER DIAM. 220 • AUTOMATIC BELT TENSIONER AND CENTRAL GREASING SYSTEM • BASKET CAPACITY FROM 1,20 TO 1,60 (M3) • HYDRAULIC OPENING BASKET • STONE-GUARD RUBBERS • CARDAN

FR CARACTERISTIQUES TECHNIQUES DE SERIE: BROYEUR POLYVALENT AVEC RAMASSEUR AVEC DISPOSITIF DE DÉCHARGEMENT PAR LE BAS, POUR LE HACHAGE DE L'HERBE, DES SARMENTS, DES VERGERS ET DES VIGNOBLES DE MOYENNES DIMENSIONS (DIAM. 7-8 CM) • GALET ARRIÈRE RÉGLABLE (DIAM. 220) • TENDEUR DE COURROIE AUTOMATIQUE ET SYSTÈME DE LUBRIFICATION CENTRALISÉ • CONTENANCE DU CASIER ENTRE 1,20 ET 1,60 (M3) • OUVERTURE HYDRAULIQUE DU CASIER • BANDES ANTI-PIERRES • CARDAN

DE TECHNISCHE SERIENDATEN: MEHRZWECK-SCHNEIDMASCHINE MIT UNTEREM AUFNEHMER EIGNET SICH FÜR DIE BEARBEITUNG VON GRAS, ZWEIGEN IN OBSTGÄRTEN, WEINBERGEN MITTLERER ABMESSUNGEN VON 7 BIS 8 CM DURCHMESSER • REGULIERBARE HINTERE WALZE DURCHMESSER 220 • AUTOMATISCHER RIEMENSPIANNER UND ZENTRALSCHMIERSYSTEM • KORBFASSUNGSVERMÖGEN VON 1,20 BIS 1,60 (M3) • HYDRAULISCHES KORBOFFNUNGSSYSTEM • STEINSCHUTZBÄNDER • KARDANGELENK

ES CARACTERÍSTICAS TÉCNICAS DE SERIE: TRINCHADORA POLIVALENTE CON RECOGEDOR INFERIOR, IDONEA PARA TRABAJOS EN HIERBA, SARMIENTOS, FRUTALES, VIÑEDOS DE MEDIAS DIMENSIONES DIAM. 7-8 CM • RODILLO TRASERO AJUSTABLE DIAM. 220 • TENSOR DE CORREA AUTOMÁTICO Y SISTEMA DE ENGRASE CENTRALIZADO • CAPACIDAD CESTA DE 1,20 A 1,60 (M3) • APERTURA HIDRAULICA CESTA • BANDAS PROTECTORAS • CARDAN

TCB	mm			HP			n°			Rpm			Kg		
	A	B	C	A	B	C	A	B	C	A	B	C	A	B	C
160	1850	2000	1470	70 - 80	26	540/1000	1850	2000	1470	1120					
190	2150	2000	1470	90 - 100	32	540/1000	2150	2000	1470	1250					
225	2500	2000	1470	100 - 110	38	540/1000	2500	2000	1470	1350					

TCA

PROFESSIONAL LINE

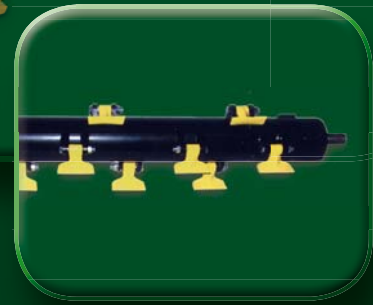

- MAZZE MF 3
- HAMMER MF 3
- FLEAUX MF 3
- HAMMER MF 3
- MAZAS MF 3

CARATTERISTICHE TECNICHE DI SERIE: TRINCIATRICE POLIVALENTE CON RACCOGLITORE SCARICO ALTO, ADATTA PER LA LAVORAZIONE SU ERBA, SARMENTI, FRUTTETI, VIGNETI DI MEDIE DIMENSIONI DIAM. DIAM. 7-8 CM • RULLO POSTERIORE DIAM. 220 • TENDICINGHIA AUTOMATICO E SISTEMA DI INGRASSAGGIO CENTRALIZZATO • CAPACITA' CESTELLO DA 1,20 A 1,60 (M3) • APERTURA IDRAULICA CESTELLO • ALTEZZA DI SCARICO MAX 2,20 mt • BANDELLE PARASASSI • CARDANO

TECHNISCHE SERIENDATEN: MEHRZWECK-SCHNEIDMASCHINE MIT OBEREN AUFNEHMER FÜR DIE ENTLADUNG EIGNET SICH FÜR DIE BEARBEITUNG VON GRAS, ZWEIGEN, IN OBSTGÄRTEN UND WEINBERGEN MITTLERER ABMESSUNGEN VON 7 BIS 8 CM DURCHMESSER • HINTERE WALZE DURCHMESSER 220 • AUTOMATISCHER RIEMENSCHNUR UND ZENTRALSCHMIERSYSTEM • KORBFASSUNGSVERMÖGEN VON 1,20 BIS 1,60 (M3) • HYDRAULISCHES KORBÖFFNUNGSSYSTEM • MAX. ENTLADEHÖHE 2,20 M • STEINSCHUTZBÄNDER • KARDANGELLENK

CARACTERÍSTICAS TÉCNICAS DE SERIE: TRINCHADORA POLIVALENTE CON RECOGEDOR DESCARGA SUPERIOR, IDONEA PARA TRABAJOS EN HIERBA, SARMIENTOS, FRUTALES, VIÑEDOS DE MEDIAS DIMENSIONES DIAM. 7-8 CM • RODILLO TRASERO AJUSTABLE DIAM. 220 • TENSOR DE CORREA AUTOMATICO Y SISTEMA DE ENGRASE CENTRALIZADO • CAPACIDAD CESTA DE 1,20 A 1,60 (M3) • APERTURA HIDRAULICA CESTA • ALTURA DE DESCARGA MAX 2,20 m • BANDAS PROTECTORAS • CARDAN

CURRENT TECHNICAL FEATURES: VERSATILE SHREDDER WITH WASTE HIGH COLLECTOR, SUITABLE FOR WORKING GRASS, WOOD, ORCHERDS, VINEYARDS OF MEDIUM DIMENSIONS DIAM. 7-8 CM • REAR ROLLER DIAM. 220 • AUTOMATIC BELT TENSIONER AND CENTRAL GREASING SYSTEM • BASKET CAPACITY FROM 1,20 TO 1,60 (M3) • HYDRAULIC OPENING BASKET • MAX DUMPING HEIGHT 2,20 mt • STONEGUARD RUBBERS • CARDAN

CARACTERISTIQUES TECHNIQUES DE SERIE: BROYEUR POLYVALENT AVEC RAMASSEUR ET DISPOSITIF DE DÉCHARGEMENT PAR LE HAUT, POUR LE HACHAGE DE L'HERBE, DES SARMENTS, DES VERGERS ET DES VIGNOBLES DE MOYENNES DIMENSIONS (DIAM. 7-8 CM) • GALET ARRIÈRE RÉGLABLE (DIAM. 220) • TENDEUR DE COURROIE AUTOMATIQUE ET SYSTÈME DE LUBRIFICATION CENTRALISÉ • CONTENANCE DU CASIER ENTRE 1,20 ET 1,60 (M3) • OUVERTURE HYDRAULIQUE DU CASIER • HAUTEUR DE DÉCHARGEMENT MAX 2,20 M • BANDES ANTI-PIERRES • CARDAN

TCA								
	mm	HP	n°	Rpm				A
160	1550	85 - 95	16	540 1000 opt.	1800	1940	1760	1390
190	1850	100 - 120	20	540 1000 opt.	2150	1940	1760	1500
225	2200	100 - 120	24	540 1000 opt.	2500	1940	1760	1580

Un mondo di soluzioni

A lot of solutions - Un monde de solutions - Viele Lösungen - Un mónnton de soluciónes

TSK

PROJET
AGRICULTURE



COLTELLI Y 205
KNIVES Y 205
COUPEAUX Y 205
MESSER Y 205
COUCHILLAS Y 205



MAZZE MF 6
HAMMER MF 6
FLEAUX MF 6
HAMMER MF 6
MAZAS MF 6

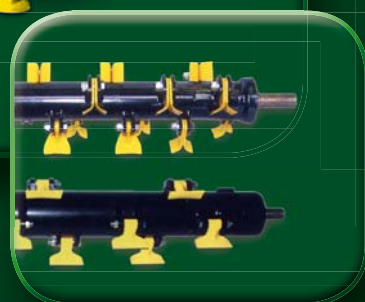









CARATTERISTICHE TECNICHE DI SERIE: TRINCIATRICE UNIVERSALE, ADATTA PER LA LAVO-RAZIONE DI STOCCHI DI PAGLIA, MAIS, GIRASOLE, CARCIOFI, PATATE, SARMENTI, ERBA • MULTIPLI-CATORE CON RUOTA LIBERA INTERNA • GIUNTO CARDANICO • SPOSTAMENTO DOPPIO ATTACCO PER MOD. 200-230 • SPOSTAMENTO ATTACCO FISSO CENTRALE PER MOD. 160-260-280 • COFANO POSTERIORE APRIBILE CON CERNIERE PER ISPE-ZIONE E MANUTENZIONE • CONTROCOLTELLO DENTATO • BANDELLE PARASASSI

TECHNISCHE SERIENDATEN: DIE UNIVERSALE SCHNEIDEMASCHINE EIGNET SICH ZUR BEARBEITUNG VON STROHANPFLANZUNGEN, MAIS, SONNENBLUMEN, MANGOLD, ARTISCHOCKEN, KARTOFFELN, ZUM LICHTEN, GRAS • ÜBERSETZUNGSGETRIEBE MIT INNEREM FREI-LAUF • KARDANGELENK • VERSCHIEBUNG DURCH DOP-PELTE KUPPLUNG MODELL 200-230 • VERSCHIEBUNG DURCH FESTSITZENDE ZENTRALE KUPPLUNG FÜR MO-DELL 160-260-280 • AUFKLAPPBARE HINTERE HAUBE MIT SCHARNIEREN FÜR DIE INSPEKTION UND DIE WARTUNG • GEZACKTE GEGENSCHNEIDE • STEINSCHUTZBÄNDER

CARACTERÍSTICAS TÉCNICAS DE SERIE: TRINCHADORA UNIVERSAL, IDONEA PARA TRABAJAR CON ALMACENAMIENTO DE PAJA, MAIZ, GIRASOL, ALCACHOFAS, PAPA, SARMIENTOS, HIERBA • MULTIPLICADOR CON RUEDA LIBRE INTERNA • JUNTA CAR-DANICA • DESPLAZAMIENTO DOBLE ENGANCHE PARA MODELOS 200-230 • DESPLAZAMIENTO ENGANCHE FIJO CENTRAL PARA MODELOS 160-260-280 • COFRE TRASERO ABRIBLE CON BISAGRAS PARA INSPECCION Y MANTENIMIENTO • CONTRACUCHILLA DENTADA • BANDAS PARAPIEDRAS

CURRENT TECHNICAL FEATURES: UNIVERSAL SHREDDER, SUITABLE FOR WORKING WITH STRAW STOCKS, MAIZE, SUNFLOWER, ARTICHOKE, POTATOES, VINE-BRANCHES, GRASS • OVERGEAR WITH INSI-DE FREE WHEEL • UNIVERSAL JOINT FOR • DOUBLE COUPLING SHIFT FOR MOD. 200-230 • FIXED CENTRAL COUPLING SHIFT FOR MOD. 160-260-280 • REAR HINGED HOOD FOR INSPECTION AND MAINTENANCE • TOOTHED COUNTER-ACTING KNIFE • STONEGUARD STRAPS

CARACTERISTIQUES TECHNIQUES DE SE-RIE: HACHEUSE UNIVERSELLE POUR LE HACHAGE DE STOCKS DE PAILLE, MAÏS, TOURNESOL, ARTICHAUTS, POMMES DE TERRE, SARMENTS, HERBE • MULTIPLI-CATEUR A ROUE LIBRE INTERNE • CARDAN • DEPLA-CEMENT DOUBLE RACCORD POUR MOD. 200 - 230 • DEPLACEMENT RACCORD FIXE CENTRAL POUR MOD. 160-260-280 • CARTER ARRIERE OUVRANT AVEC CHAR-NIERE POUR VISITE ET MAINTENANCE • CONTRE-COU-TEAU CRANTE • BANDE ANTI-PIERRES

TSK											
	mm	HP (min-max)	MF6 n°	Y205 n°	n°	Rpm	A	B	C	Kg	
160	1570	50 - 80	16	32	4	540	1450	1750	1050	550	
200	1970	50 - 80	20	40	4	540	1450	2150	1050	685	
230	2270	50 - 90	24	48	4	540	1450	2450	1050	760	
260	2570	70 - 110	28	56	5	540	1450	2750	1050	835	
280	2770	70 - 110	32	64	5	540	1450	2950	1050	885	
300	2970	70 - 130	34	68	5	540	1450	3150	1050	970	

TR

PROFESSIONAL LINE



TPR

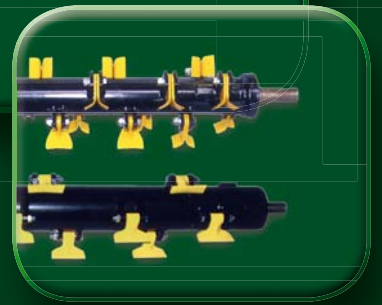

CARATTERISTICHE TECNICHE DI SERIE:
 TRINCIATRICE SPECIALE CON RIMORCHIO CONTENITORE ADATTA PER LA LAVORAZIONE SU ERBA E PICCOLI ARBUSTI FRUTTETI, VIGNETI, ULIVETO FINO A DIAM. 5 CM • IL RESIDUO DELLA TRITURAZIONE VIENE CARICATO NEL CONTENITORE A RIMORCHIO • ALTEZZA MAX DI SCARICO DEL RIMORCHIO 2,8 MT • COLTELLI A PALETTA • RULLO POSTERIORE REGOLABILE • TENDICINGHIA AUTOMATICO E SISTEMA DI INGRASSAGGIO CENTRALIZZATO • SLITTE • REGOLAZIONE DEL TAGLIO ELETTRO-IDRAULICA • SPOSTAMENTO IDRAULICO BILATERALE • COMANDI ELETTRO IDRAULICI CON JOYSTIC • CARDANO

- COLTELLI Y 410
- KNIVES Y 410
- COUTEAUX Y 410
- MESSER Y 410
- COUCHILLAS Y 410

- MAZZE MF 3
- HAMMER MF 3
- FLEAUX MF 3
- HAMMER MF 3
- MAZAS MF 3

CURRENT TECHNICAL FEATURES: SPECIAL SHREDDER WITH TRAILED CONTAINER SUITABLE FOR WORKING ON GRASS AND SMALL SHRUBS, ORCHARDS, VINEYARDS, OLIVE GRIVES UP TO A DIAM OF 5 CM • THE RESTS OF GREEDING ARE LOADED IN A TRAILED CONTAINER • MAX TRAILER DISCHARGE 2.8 MT • PALETTE KNIVES • ADJUSTABLE REAR ROLL • AUTOMATIC BELT TENSIONER AND CENTRAL GREASING SYSTEM • SLIDES • ELECTRO-HYDRAULIC CUT ADJUSTMENT • BILATERAL HYDRAULIC DISPLACEMENT • ELECTRO-HYDRAULIC CONTROL WITH JOYSTICK • CARDAN

CARACTERISTIQUES TECHNIQUES DE SERIE: BROUEUR SPECIAL AVEC REMORQUE AVEC BIDON POUR LE HACHAGE DE L'HERBE ET DE PETITS ARBUSTES DES VERGERS, DES VIGNOBLES ET DES OLIVERAIRES JUSQU'A 5 CM DE DIAM. • LES RESIDUS DU HACHAGE EST CHARGÉ DANS LE BIDON À REMORQUE • HAUTEUR MAX DE DÉCHARGEMENT DE LA REMORQUE 2,8 M • COUTEAUX-PALETTES • GALET ARRIÈRE RÉGLABLE • TENDEUR DE COURROIE AUTOMATIQUE ET SYSTÈME DE LUBRIFICATION CENTRALISÉ • GLISSIÈRES • RÉGLAGE ÉLECTRO-HYDRAULIQUE DE LA TAILLE • DÉPLACEMENT HYDRAULIQUE BILATÉRAL • COMMANDES ÉLECTRO-HYDRAULIQUES AVEC JOYSTICK • CARDAN

TECHNISCHE SERIENDATEN: SPEZIALSCHNEIDMASCHINE MIT ANHÄNGER FÜR GRAS UND KLEINE BÜSCHEZWEIGEN IN OBSTGÄRTEN, WEINBERGEN, OLIVENHAINEN MIT DURCHMESSER BIS 5 CM • DIE ZERKLÄINERUNGSRESTE WERDEN IN DEN BUNKER DES AUFHÄNGERS GELADEN • MAX. ENTLADEHÖHE DES AUFHÄNGERS 2,8 M • SCHAUFELFÖRMIGE MESSER • VERSTELLBARE HINTERE WALZE • AUTOMATISCHER RIEMENSCHNÄPPEL UND ZENTRALSCHMIERSYSTEM • SCHLITTEN • ELEKTRO-HYDRAULISCHE SCHNITTEINSTELLUNG • ZWEISEITIGE HYDRAULISCHE VERSCHIEBUNG • ELEKTRO-HYDRAULISCHE STEUERUNGEN MIT STEUERKNÜPPEL • KARDANGELLENK

CARACTERÍSTICAS TÉCNICAS DE SERIE: TRINCHADORA ESPECIAL CON RECIPIENTE ARRASTRADO IDONEA PARA TRABAJOS EN HIERBA Y PEQUEÑOS ARBUSTOS, FRUTALES, VIÑEDOS, PLANTACIONES DE OLIVOS HASTA DIAM. 5 CM • LOS RESIDUOS DE TRITURACION SE CARGAN EN EL RECIPIENTE ARRASTRADO • ALTURA MAX DE DESCARGA DEL REMOLQUE 2,8 M • CUCHILLAS DE PALETA • RODILLO TRASERO AJUSTABLE • TENSOR DE CORREA AUTOMÁTICO Y SISTEMA DE ENGRASE CENTRALIZADO • CORREDERAS • AJUSTE ELECTRO-HIDRAULICO DEL CORTE • MOVIMIENTO HIDRAULICO BILATERAL • MANDO ELECTROHIDRAULICO MEDIANTE PALANCA DE MANDO • CARDAN

TR	mm		HP (min-max)	n°	Rpm	mm			Kg
	A	B				C			
140	1350	50 - 80	14	540	1800	4650	2500	2200	
190	1850	80 - 90	20	540	2400	6280	2750	3950	

Un mondo di soluzioni

A lot of solutions - Un monde de solutions - Viele Lösungen - Un món ton de solució nes

TSP

PROJET

AGRICULTURE

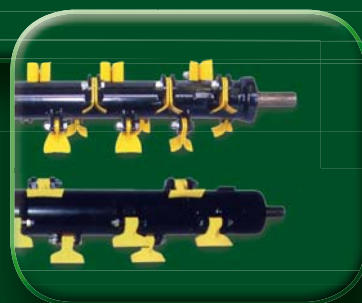

- COLTELLI Y 205
- KNIVES Y 205
- COUPEAUX Y 205
- MESSER Y 205
- COUCHILLAS Y 205

- MAZZE MF 6
- HAMMER MF 6
- FLEAUX MF 6
- HAMMER MF 6
- MAZAS MF 6

CURRENT TECHNICAL FEATURES: MULTIPURPOSE FOLDING SHREDDER FOR GREAT DIMENSIONS, SUITABLE FOR WORKING ON GRASS, WOODS, STRAW, MAIZE, SUNFLOWERS, ARTICHOKE, POTATOES • DOUBLE ROTOR • DOUBLE COUNTER • KNIFE • ADJUSTABLE SELF CLEANING REAR ROLLER WITH ADJUSTABLE SPHERICAL BEARINGS • ADJUSTABLE SLIDES • QUICK BAR • DOUBLE FRAME • AUTOMATIC BELT TENSIONER • CENTRAL GREASING SYSTEM • MECHANICAL SAFETY FOR TRANSPORT ON ROAD • STONEGUARD RUBBERS • CARDAN

CARACTERISTIQUES TECHNIQUES DE SERIE: BROYEUR POLYVALENT REPLIABLE POUR GRANDES EXPLOITATIONS, POUR LE HACHAGE DE L'HERBE, DES SARMENTS, DE LA PAILLE, DU MAÏS, DU TOURNESOL, DES ARTICHAUTS, DES POMMES DE TERRE • DOUBLE ROTOR • DOUBLE CONTRE-COUCHEAU • ROULEAU ARRIERE AUTONETTOYANT REGLABLE AVEC ROUELEMENTS A BILLES ORIENTABLES • GLISSIERES REGLABLES • RAMPE ATTELAGE RAPIDE • DOUBLE CHASSIS • TENDEUR DE COURROIE AUTOMATIQUE • SYSTEME DE LUBRIFICATION CENTRALISE • SECURITE MECANIQUE POUR TRANSPORT SUR ROUTE • BANDES ANTI-PIERRES • CARDAN

CARATTERISTICHE TECNICHE DI SERIE: TRINCIATRICE POLIVALENTE PIEGHEVOLE PER GRANDI ESTENSIONI, ADATTA PER LA LAVORAZIONE SU ERBA, SARMENTI, PAGLIA, MAIS, GIRASOLE, CARGIOFI, PATATE • DOPPIO ROTORE • DOPPIO CONTROCOLTELLO • RULLO POSTERIORE AUTOPULENTE REGOLABILE CON CUSCINETTI ORIENTABILI A RULLI • SLITTE REGOLABILI • BARRA ATTACCO RAPIDO • DOPPIO TELAIO • TENDICINGHIA AUTOMATICO • SISTEMA DI INGRASSAGGIO CENTRALIZZATO • SICUREZZA MECCANICA PER TRASPORTO SU STRADA • BANDELLE PARASASSI • CARDANO

TECHNISCHE SERIENDATEN: BIEGBARE MEHRZWECK-SCHNEIDMASCHINE FÜR WEITREICHENDE FELDER EIGNET SICH FÜR DIE BEARBEITUNG VON GRAS, ZWEIGEN, STROH, MAIS, SONNENBLUMEN, ARTISCHOCKEN UND KARTOFFELN • DOPPELROTOR • DOPPELGEGENSCHNEIDE • HINTERE SELBSTREINIGENDE WALZE, EINSTELLBAR MIT ROLLENLAGERN • EINSTELLBARE SCHLITTEN • LEISTE SCHNELLVERBINDUNG • DOPPELRAHMEN • AUTOMATISCHER RIEMENSPELLNER • ZENTRALSCHMIERSYSTEM • MECHANISCHES SICHERHEITSSYSTEM FÜR TRANSPORT AUF STRASSE • STEINSCHUTZBÄNDER • KARDANGELENK

CARACTERÍSTICAS TÉCNICAS DE SERIE: TRINCHADORA POLIVALENTE PLEGABLE PARA AMPLIAS EXTENSIONES, IDONEA PARA TRABAJOS EN HIERBA, SARMIENTOS, PAJA, MAIZ, GIRASOL, ALCAHOFA, PATATAS • ROTOR DOBLE • CONTRACUCHILLA DOBLE • RODILLO TRASERO AUTOLIMPIANTE AJUSTABLE CON COJINETES ORIENTABLES DE RODILLOS • CORREAS AJUSTABLES • BARRA DE ENGANCHE RAPIDO • BASTIDOR DOBLE • TENSOR DE CORREA AUTOMATICO Y SISTEMA DE ENGRASE CENTRALIZADO • SEGURIDAD MECANICA PARA TRANSPORTE POR CARRETERA • BANDAS PROTECTORAS • CARDAN

TSP									
	mm	HP	n°	n°	Rpm	A	B	C	Kg
480	4800	130 - 140	48	96	540/1000	5200	1250	1600	2220
520	5200	150 - 160	52	104	540/1000	5600	1250	1600	2420
560	5600	150 - 160	56	112	540/1000	6000	1250	1600	2500
600	6000	160 - 180	60	120	540/1000	6400	1250	1600	2600
640	6400	160 - 180	64	124	540/1000	6800	1250	1600	2780

PROFESSIONAL LINE

TST

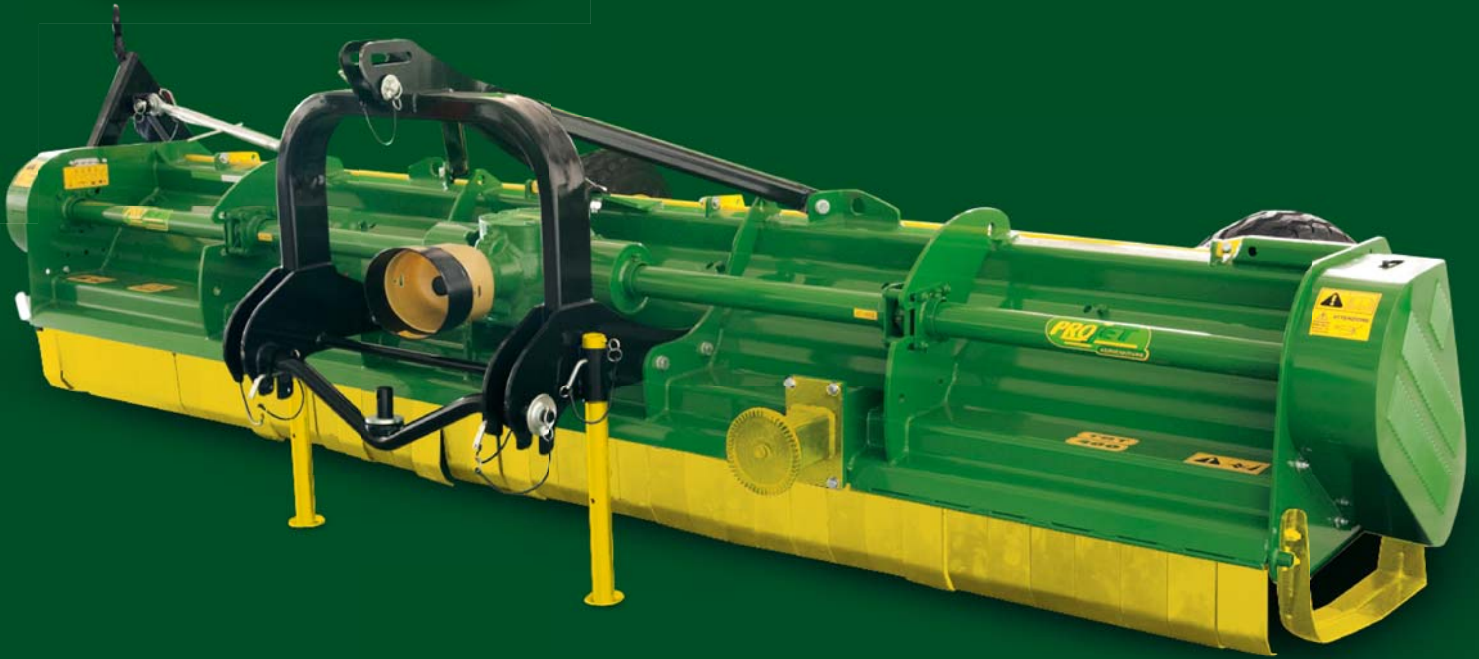

-  COLTELLI Y 205
-  KNIVES Y 205
-  COUTEAUX Y 205
-  MESSER Y 205
-  COUCHILLAS Y 205



-  MAZZE MF 6
-  HAMMER MF 6
-  FLEAUX MF 6
-  HAMMER MF 6
-  MAZAS MF 6

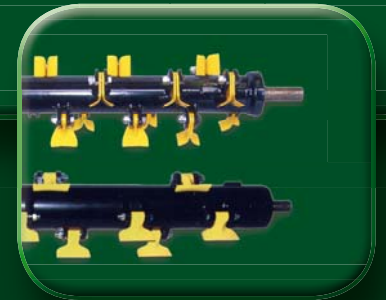







CARATTERISTICHE TECNICHE DI SERIE: TRINCIATRICE POLIVALENTE PER GRANDI ESTENSIONI, ADATTA PER LA LAVORAZIONE SU ERBA, SARMENTI, PAGLIA, MAIS, GIRASOLE, CARCIOFI, PATATE • RUOTE POSTERIORI REGOLABILI IN ALTEZZA • SLITTE REGOLABILI • DOPPIA CENTINA • BARRA AT TACCO RAPIDO • MONOROTORE • TENDICINGHIA AUTOMATICO E SISTEMA DI INGRASSAGGIO CENTRALIZZATO • 2 COFANI APRIBILI PER MANUTENZIONE • SISTEMA DI TRASPORTO SU STRADA • BANDELLE PARASASSI • CARDANO

TECHNISCHE SERIENDATEN: MEHRZWECKSCHNEIDEMASCHINE FÜR WEITREICHENDE FELDER EIGNET SICH FÜR DIE BEARBEITUNG VON GRAS, ZWEIGEN, STROH, MAIS, SONNENBLUMEN, ARTISCHOCKEN UND KARTOFFELN • HÖHENEINSTELLBARE HINTERE RÄDER • EINSTELLBARE SCHLITTEN • DOPPELSPRIEGEL • LEISTE SCHNELVERBINDUNG • MONOROTOR • AUTOMATISCHER RIEMENSPIANNER UND ZENTRALSCHMIERSYSTEM • ZWEI AUFKIPPBARE HAUBEN FÜR DIE WARTUNG • TRANSPORTSYSTEM AUF STRASSE • STEINSCHUTZBÄNDER • KARDANGELNENK

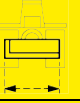
CARACTERÍSTICAS TÉCNICAS DE SERIE: TRINCHADORA POLIVALENTE PARA AMPLIAS EXTENSIONES, IDONEA PARA TRABAJOS EN HIERBA, SARMIENTOS, PAJA, MAIZ, GIRASOL, ALCACHOFAS, PATATAS • RUEDAS TRASERAS AJUSTABLES EN ALTURA • CORREDERAS AJUSTABLES • CERCHA DOBLE • BARRA DE ENGANCHE RAPIDO • ROTOR SIMPLE • TENSOR DE CORREA AUTOMATICO Y SISTEMA DE ENGRASE CENTRALIZADO • 2 COFRES ABRIBLES PARA MANTENIMIENTO • SISTEMA DE TRANSPORTE POR CARRETERA • BANDAS PROTECTORAS • CARDAN

CURRENT TECHNICAL FEATURES: VERSATILE SHREDDER FOR WASTE EXTENSIONS, SUITABLE FOR WORKING ON GRASS, WOODS, STRAW, MAIZE, SUNFLOWERS, ARTICHOKE, POTATOES • REAR WHEELS ADJUSTABLE IN HEIGHT • ADJUSTABLE SLIDES • DOUBLE RIBS • QUICK BAR • SINGLE ROTOR • AUTOMATIC BELT TENSIONER AND CENTRAL GREASING SYSTEM • 2 OPENING BONNETS FOR MAINTENANCE • ROAD TRANSPORT SYSTEM • STONEGUARD RUBBERS • CARDAN

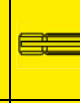
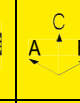
CARACTERISTIQUES TECHNIQUES DE SERIE: BROYEUR POLYVALENT POUR GRANDES EXPLOITATIONS, POUR LE HACHAGE DE L'HERBE, DES SARMENTS, DE LA PAILLE, DU MAÏS, DU TOURNESOL, DES ARTICHAUX, DES POMMES DE TERRE • ROUES ARRIÈRE RÉGLABLES EN HAUTEUR • GLISSIÈRES RÉGLABLES • DOUBLE ARCEAU • RAMPE À ATTELAGE RAPIDE • MONOROTOR • Tendeur de courroie automatique et système de lubrification centralisée • 2 CARTER OUVRANTS POUR MAINTENANCE • SYSTÈME DE TRANSPORT SUR ROUTE • BANDES ANTI-PIERRES • CARDAN

TST									
	mm	HP	n°	n°	Rpm	A	B	C	Kg
320	3200	90 - 110	40	80	1000	3600	1600	1500	1600
400	4000	90 - 110	50	100	1000	4400	1600	1500	2000
450	4500	110 - 130	56	112	1000	4900	1600	1500	2380

Un mondo di soluzioni

A lot of solutions - Un monde de solutions - Viele Lösungen - Un mónnton de soluciónes

BRKB

PROJET
AGRICULTURE

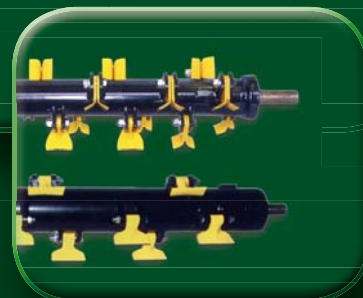

- COLTELLI Y 405
- KNIVES Y 405
- COUTEAUX Y 405
- MESSER Y 405
- COUCHILLAS Y 405

- MAZZE MF 9
- HAMMER MF 9
- FLEAUX MF 9
- HAMMER MF 9
- MAZAS MF 9

CURRENT TECHNICAL FEATURES: DESIGNED FOR APPLICATION ON SMALL AND MEDIUM POWER TRACTORS, IDEAL FOR CLEANING DITCHES, BANKS AND THE MAINTENANCE OF PUBLIC GREEN AREAS, SUITABLE FOR SHREDDING SHRUBBERY UP TO 2-3 CM IN DIAMETER. • OVERGEAR WITH INSIDE FREE WHEEL • HYDRAULIC SIDE SHIFT WITH SWAYING JUNCTION • SELF-LEVELLING HYDRAULIC HEAD SLANT • ADJUSTABLE DIAM. 140 ROLLER • STONEGUARD STRAPS • SELF-LEVELLING JUNCTION TRACTOR SIDE • UNIVERSAL JOINT

CARACTERISTIQUES TECHNIQUES DE SERIE: CREEE POUR ETRE EMPLOYEE SUR DES TRACTEURS DE PETITE ET MOYENNE PUISSANCE, ELLE EST IDEALE POUR L'ENTRETIEN DE RIVES ET FOSSES, DES BORDS AINSI QUE PUOR LA MAINTENANCE DES ESPACES VERTS. ELLE EST INDIQUEE POUR LE BROYAGE D'ARBUSTES ATTEIGNANT UN DIAMETRE DE 2 A 3 CM MAXI • GROUPE MULTIPLICATEUR A ROUE LIBRE INTERNE • DEPLACEMENT LATERAL HYDRAULIQUE AVEC ARTICULATION OSCILLANTE • INCLINAISON TETE HYDRAULIQUE A REGLAGE AUTOMATIQUE DE MISE A NIVEAU • GALET REGLABLE DIAMETRE 140 • BANDE ANTI-PIERRES. ARTICULATION A REGLAGE AUTOMATIQUE DE MISE A NIVEAU COTE TRACTEUR • CARDAN

CARATTERISTICHE TECNICHE DI SERIE: CREATA PER L'APPLICAZIONE SU TRATTORI DI PICCOLA E MEDIA POTENZA, IDEALE PER LA PULIZIA DI FOSSATI, RIVE E PER LA MANUTENZIONE DEL VERDE PUBBLICO. ADATTA PER LA TRITURAZIONE DI ARBUSTI FINO A Ø 2+3 CM. • GRUPPO MOLTIPLICATORE CON RUOTA LIBERA INTERNA • SPOSTAMENTO LATERALE IDRAULICO CON SNODO OSCILLANTE • INCLINAZIONE TESTATA IDRAULICA AUTOLIVELLANTE • RULLO REGOLABILE Ø 140 • BANDELLE PARASASSI • SNODO AUTOLIVELLANTE LATO TRATTRICE • GIUNTO CARDANICO

TECHNISCHE SERIENDATEN: ZUR VERWENDUNG AUF SCHLEPPERN MIT NIEDRIGER BIS MITTLERER LEISTUNG, IDEAL ZUM REINIGEN VON GRÄBEN, UFERN UND ZURPFLEGE VON ÖFFENTLICHEN GRÜNANLAGEN, ZUM MULCHEN VON BÜSCHERN MIT EINEM DURCHMESSER BIS 2-3 CM. • ÜBERSETZERGRUPPE MIT UMKEHRSCHALTUNG UND MIT INNEREM FREILAUF • HYDRAULISCHE SEITLICHE VERSCHIEBUNG MIT OSZILLIERENDEM GELENK • NEIGUNG DES HYDRAULISCHEN SELBSTNIVELLIERENDEN KOPFSTÜCKS • REGULIERBARE WALZE 140 Ø • STEINSCHUTZBÄNDER • SELBSTNIVELLIERENDES GELENK AUF DER SEITE DES SCHLEPPERS • KARDANGELENK

CARACTERÍSTICAS TÉCNICAS DE SERIE: CREADA PARA SER APLICADA EN TRACTORES DE PEQUEÑA Y MEDIANA POTENCIA, ES IDEAL PARA LIMPIAR FOSOS Y CUNETAS Y PARA EL MANTENIMIENTO DE ZONAS VERDES PUBLICAS. APTA PARA DESMENUZAR ARBUSTOS DE DIAMETRO HASTA 2-3 CM. • GRUPO MULTIPLICADOR CON RUEDA LIBRE INTERNA • DESPLAZAMIENTO LATERAL HIDRAULICO CON ARTICULACION OSCILANTE • INCLINACION DEL CABEZAL HIDRAULICO AUTONIVELADOR • RODILLO REGULABLE DE 140 DE DIAMETRO • BANDAS PARAPIEDRAS • ARTICULACION AUTONIVELADORA LADO TRACTOR • JUNTA CARDANICA

BRKB													
	mm	Kw - HP	n°	n°	Rpm	n°		A	B	C	D	E	
130	1270	26 - 35	18	36+18	540	3	500	900	1400	1290	1850	1450	307
150	1470	29 - 40	20	40+20	540	3	500	1100	1600	1290	2050	1450	340
175	1720	37 - 50	24	48+24	540	3	500	1350	1850	1290	2400	1450	375

PROFESSIONAL LINE

BRKM

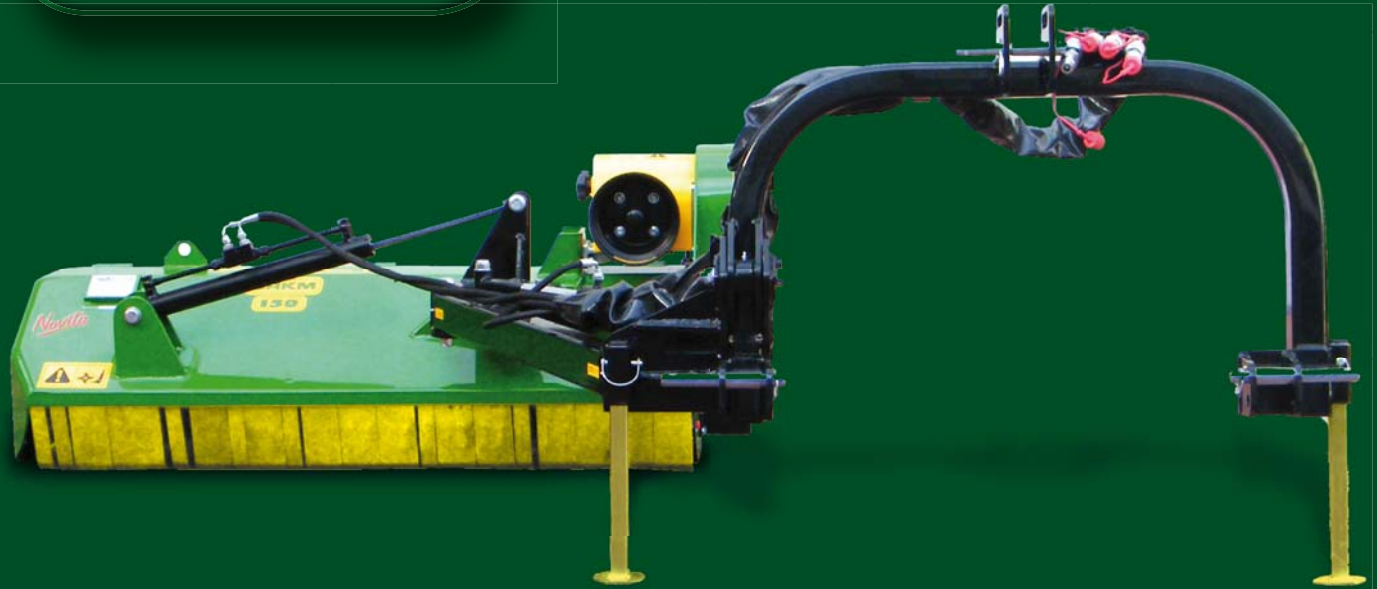

-  COLTELLI Y 410
-  KNIVES Y 410
-  COUTEAUX Y 410
-  MESSER Y 410
-  COUCHILLAS Y 410



-  MAZZE MF 9
-  HAMMER MF 9
-  FLEAUX MF 9
-  HAMMER MF 9
-  MAZAS MF 9











CARATTERISTICHE TECNICHE DI SERIE: LA TRINCIATRICE È ADATTA PER IL TAGLIO DI ERBA, TRITURAZIONE DI CANNETI, ARBUSTI FINO A Ø 3+4 CM SU BORDI STRADALI, RIVE E FOSSATI • GRUPPO MOLTIPLICATORE CON RUOTA LIBERA INTERNA • SCOCCA CON DOPPIA STRUTTURA INTERNA • SPOSTAMENTO LATERALE IDRAULICO CON SNODO OSCILLANTE • INCLINAZIONE TESTATA IDRAULICA AUTOLIVELLANTE • RULLO REGOLABILE DIAM. 170 • COFANO POSTERIORE APRIBILE CON CERNIERE PER ISPEZIONE E MANUTENZIONE • BANDELLE PARASASSI • SNODO AUTOLIVELLANTE LATO TRATTRICE • GIUNTO CARDANICO

TECHNISCHE SERIENDATEN: DIE SCHNEIDEMASCHINE IST FÜR DEN GRASSCHNITT, ZERKLEINERUNG DES RÖHRICHTS, FÜR HECKEN BIS ZU Ø 3+4 CM DURCHMESSER AN STRASSENRÄNDERN, FLUßHÄNGEN UND WASSERGRÄBEN GEEIGNET • ÜBERSETZERGRUPPE MIT UMKEHRSCHALTUNG UND MIT INNEREM FREILAUF, HYDRAULISCHE SEITLICHE VERSCHIEBUNG MIT OSZILLIERENDEM GELENK • KAROSSE-RIEKÖRPER MIT INNERER DOPPELTEN STRUKTUR • NEIGUNG DES HYDRAULISCHEN SELBSTNIVELLIERENDEN KOPFSTÜCKS • REGULIERBARE WALZE 170 Ø • AUFKLABBARE HINTERE HAUBE MIT SCHARNIEREN FÜR DIE INSPEKTION UND DIE WARTUNG • STEINSCHUTZBÄNDER • SELBSTNIVELLIERENDES GELENK AUF DER SEITE DES SCHLEPPERS • KARDANGELLENK

CARACTERÍSTICAS TÉCNICAS DE SERIE: LA TRINCHADORA ES IDONEA PARA EL CORTE DE HIERBA, TRITURACION DE CAÑALES, ARBUSTOS HASTA Ø 3+4 CM SOBRE BORDOS DE LA VIA PÚBLICA, ORILLAS Y ZANJAS • GRUPO MULTIPLICADOR CON RUEDA LIBRE INTERNA • CARROCERIA CON DOBLE ESTRUCTURA INTERNA • DESPLAZAMIENTO LATERAL HIDRAULICO CON ARTICULACION OSCILANTE • INCLINACION DEL CABEZAL HIDRAULICO AUTONIVELADOR • RODILLO REGULABLE DE 170 DE DIAMETRO • COFRE TRASERO ABRIBLE CON BISAGRAS PARA INSPECCION Y MANTENIMIENTO • PROTECCIONES CONTRA ACCIDENTES SEGUN NORMAS CE • BANDAS PARAPIEDRAS • ARTICULACION AUTONIVELADORA LADO TRACTOR • PROTECCIONES CONTRA ACCIDENTES SEGUN NORMAS CE • JUNTA CARDANICA

CURRENT TECHNICAL FEATURES: THE SHREDDER IS SUITABLE FOR CUTTING GRASS, SHREDDING REEDS AND BUSHES UP TO Ø 3+4 CM AT THE EDGES OF ROADS, EMBANKMENTS AND DITCHES • OVERGEAR WITH INSIDE FREE WHEEL • BODY WITH DOUBLE INSIDE STRUCTURE • HYDRAULIC SIDE SHIFT WITH SWAYING JUNCTION • SELF-LEVELLING HYDRAULIC HEAD SLANT • ADJUSTABLE DIAM. 170 ROLLER • REAR HINGED HOOD FOR INSPECTION AND MAINTENANCE • CE STANDARD ACCIDENT PREVENTION GUARDS • STONEGUARD STRAPS • SELF-LEVELLING JUNCTION TRACTOR SIDE • UNIVERSAL JOINT

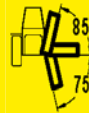
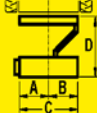
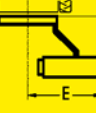
CARACTERISTIQUES TECHNIQUES DE SERIE: LA HACHEUSE EST INDIQUEE POUR LA COUPE DE L'HERBE, LA TRITURATION DE CANNAIES, D'ARBUSTES DE Ø 3+4 CM EN BORD DE ROUTE, SUR LES RIVES ET DANS LES FOSSES • GROUPE MULTIPLICATEUR A ROUE LIBRE INTERNE • COQUE AVEC DOUBLE STRUCTURE INTERNE • DEPLACEMENT LATERAL HYDRAULIQUE AVEC ARTICULATION OSCILLANTE • INCLINAISON TETE HYDRAULIQUE A REGLAGE AUTOMATIQUE DE MISE A NIVEAU • GALET REGLABLE DIAMETRE 170 • CARTER ARRIERE OUVRANT AVEC CHARNIERE POUR VISITE ET MAINTENANCE • PROTECTIONS CONTRE LES ACCIDENTS DU TRAVAIL CONFORMES AUX NORMES CE • BANDE ANTI-PIERRES, ARTICULATION A REGLAGE AUTOMATIQUE DE MISE A NIVEAU COTE TRACTEUR • PROTECTIONS CONTRE LES ACCIDENTS DU TRAVAIL CONFORMES AUX NORMES CE • CARDAN

BRKM													
	mm	Kw - HP	n°	n°	Rpm	n°	A	B	C	D	E	F	Kg
150	1470	29 - 37	16	32+16	540	4	800	800	1600	1800	2200	1950	505
175	1720	37 - 44	18	36+18	540	4	800	1050	1850	1800	2450	1950	545
200	1970	37 - 44	20	40+20	540	4	800	1300	2100	1800	2700	1950	590

Un mondo di soluzioni

A lot of solutions - Un monde de solutions - Viele Lösungen - Un mónnton de soluciónes

BRK

PROJET
AGRICULTURE



COLTELLI Y 410
KNIVES Y 410
COUTEAUX Y 410
MESSER Y 410
COUCHILLAS Y 410



MAZZE MF 3
HAMMER MF 3
FLEAUX MF 3
HAMMER MF 3
MAZAS MF 3

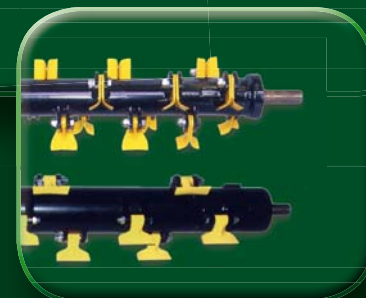

CARATTERISTICHE TECNICHE DI SERIE: LA TRINCIATRICE È ADATTA PER IL TAGLIO DI ERBA, TRITURAZIONE DI CANNETI, ARBUSTI FINO A Ø 6+8 CM SU BORDI STRADALI, RIVE E FOSSATI • GRUPPO MOLTIPLICATORE CON RUOTA LIBERA INTERNA • SCOCCA CON DOPPIA STRUTTURA INTERNA • SPOSTAMENTO LATERALE IDRAULICO CON SNODO OSCILLANTE • INCLINAZIONE TESTATA IDRAULICA AUTOLIVELLANTE • RULLO REGOLABILE Ø 170 • COFANO POSTERIORE APRIBILE CON CERNIERE PER ISPEZIONE E MANUTENZIONE • BANDELLE PARASASSI • SNODO AUTOLIVELLANTE LATO TRATTRICE • GIUNTO CARDANICO

TECHNISCHE SERIENDATEN: DIE SCHNEIDEMASCHINE IST FÜR DEN GRASSCHNITT, ZERKLEINERUNG DES RÖHRICHTS, FÜR HECKEN BIS ZU Ø 6+8 CM DURCHMESSER AN STRASSENÄNDERN, FLUßHÄNGEN UND WASSERGRÄBEN GEEIGNET • ÜBERSETZERGRUPPE MIT UMKEHRSCHALTUNG UND MIT INNEREM FREILAUF • KAROSSERIEKÖRPER MIT INNERER DOPPELTEN STRUKTUR • HYDRAULISCHE SEITLICHE VERSCHIEBUNG MIT OSZILLIERENDEM GELENK • NEIGUNG DES HYDRAULISCHEN SELBSTNIVELLIERENDEN KOPFSTÜCKS • REGULIERBARE WALZE 170 Ø • AUFLAPPBARE HINTERE HAUBE MIT SCHARNIEREN FÜR DIE INSPEKTION UND DIE WARTUNG • STEINSCHUTZBÄNDER • SELBSTNIVELLIERENDES GELENK AUF DER SEITE DES SCHLEPPERS • KARDANGELLENK

CURRENT TECHNICAL FEATURES: THE SHREDDER IS SUITABLE FOR CUTTING GRASS, SHREDDING REEDS AND BUSHES UP TO Ø 6+8 CM AT THE EDGES OF ROADS, EMBANKMENTS AND DITCHES • OVERGEAR WITH INSIDE FREE WHEEL • BODY WITH DOUBLE INSIDE STRUCTURE • HYDRAULIC SIDE SHIFT WITH SWAYING JUNCTION • SELFLEVELLING HYDRAULIC HEAD SLANT • ADJUSTABLE DIAM. 170 ROLLER • REAR HINGED HOOD FOR INSPECTION AND MAINTENANCE • STONEGUARD STRAPS • SELF-LEVELLING JUNCTION TRACTOR SIDE • UNIVERSAL JOINT

CARACTERISTIQUES TECHNIQUES DE SERIE: LA HACHEUSE EST INDIQUEE POUR LA COUPE DE L'HERBE, LA TRITURATION DE CANNAIRES, D'ARBUSTES DE Ø 6+8 CM MAX. EN BORD DE ROUTE, SUR LES BORDS ET DANS LES FOSSES • GROUPE MULTIPLICATEUR A ROUE LIBRE INTERNE • COQUE AVEC DOUBLE STRUCTURE INTERNE • DEPLACEMENT LATERAL HYDRAULIQUE AVEC ARTICULATION OSCILLANTE • INCLINAISON TETE HYDRAULIQUE A REGLAGE AUTOMATIQUE DE MISE A NIVEAU • GALET REGLABLE DIAMETRE 170 • CARTER ARRIERE OUVRANT AVEC CHARNIERE POUR VISITE ET MAINTENANCE • BANDE ANTI-PIERRES. ARTICULATION A REGLAGE AUTOMATIQUE DE MISE A NIVEAU COTE TRACTEUR • CARDAN

CARACTERÍSTICAS TÉCNICAS DE SERIE: LA TRINCHADORA ES IDONEA PARA EL CORTE DE HIERBA, TRITURACION DE CAÑALES, ARBUSTOS HASTA Ø 6+8 CM SOBRE BORDOS DE LA VÍA PÚBLICA, ORILLAS Y ZANJAS • GRUPO MULTIPLICADOR CON RUEDA LIBRE INTERNA • CARROCERIA CON DOBLE ESTRUCTURA INTERNA • DESPLAZAMIENTO LATERAL HIDRAULICO CON ARTICULACION OSCILANTE • INCLINACION DEL CABEZAL HIDRAULICO AUTONIVELADOR • RODILLO REGULABLE DE 170 DE DIAMETRO • COFRE TRASERO ABRIBLE CON BISAGRAS PARA INSPECCION Y MANTENIMIENTO • BANDAS PARAPIEDRAS • ARTICULACION AUTONIVELADORA LADO TRACTOR • JUNTA CARDANICA

BRK													
	mm	Kw - HP	MF 2	Y 505	n°	Rpm	A	B	C	D	E	F	Kg
150	1480	37 - 50 44 - 60	16	32	4	540	800	850	1650	1900	2200	2100	570
175	1730	44 - 60 50 - 70	18	36	4	540	800	1100	1900	1900	2450	2450	625
200	1980	50 - 70 59 - 80	20	40	4	540	800	1350	2550	1900	2700	2700	700

PROFESSIONAL LINE

BRKE



-  **COLTELLI Y 410**
-  **KNIVES Y 410**
-  **COUPEAUX Y 410**
-  **MESSER Y 410**
-  **COUCHILLAS Y 410**



-  **MAZZE MF 3**
-  **HAMMER MF 3**
-  **FLEAUX MF 3**
-  **HAMMER MF 3**
-  **MAZAS MF 3**

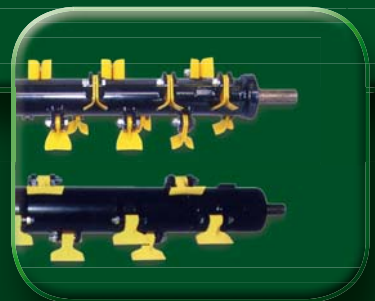













CARATTERISTICHE TECNICHE DI SERIE: TRINCIATRICE ADATTA PER IL TAGLIO DI ERBA, TRITURAZIONE DI CANNETI, ARBUSTI FINO A Ø 6-8 CM SU BORDI STRADALI, RIVE E FOSSATI • GRUPPO MOLTIPLICATORE ESTERNO CON RUOTA LIBERA • SCOCCA CON DOPPIA STRUTTURA INTERNA • SPOSTAMENTO LATERALE IDRAULICO CON SNODO OSCILLANTE • INCLINAZIONE TESTATA IDRAULICA AUTOLIVELLANTE • RULLO REGOLABILE Ø 170 • COFANO D'ISPEZIONE POSTERIORE • BANDELLE PARASASSI • SNODO LIVELLANTE LATO TRATTORE • CARDANO

TECHNISCHE SERIENDATEN: SCHNEIDEMASCHINE FÜR GRASSCHNITT, ZERKLINERUNG DES RÖHRICHTS, FÜR HECKEN BIS ZU Ø 6-8 CM DURCHMESSER AN STRASSENRÄNDERN, UFERN UND WASSERGRÄBEN GEEIGNET • EXTERNE ÜBERSETZERGRUPPE MIT FREILAUF • KAROSSERIEKÖRPER MIT INNERER VERSTÄRKTER DOPPELSTRUKTUR • HYDRAULISCHE SEITLICHE VERSCHIEBUNG MIT OSZILLIERENDEM GELENK • NEIGUNG DES HYDRAULISCHEN SELBSTNIVELLIERENDEN KOPFSTÜCKS • REGULIERBARE WALZE 170 Ø • HINTERE HAUBE FÜR DIE INSPEKTION • STEINSCHUTZBÄNDER • SELBSTNIVELLIERENDES GELENK AUF DER SEITE DES SCHLEPPERS • SCHUTZVORRICHTUNGEN, DIE DEN CE NORMEN ENTSPRECHEN • KARDANGELENK

CURRENT TECHNICAL FEATURES: SHREDDER SUITABLE FOR CUTTING GRASS, TRITURATION REEDS, SHRUBS UP TO Ø 6-8 CM ON ROAD SIDES, BANKS AND DITCHES • EXTERNAL GEAR BOX GROUP WITH FREE WHEEL FRAME WITH DOUBLE INTERNAL STRUCTURE • HYDRAULIC SWING ARM WITH LATERAL MOVEMENT SELF HEAD HYDRAULIC ANGLE • ADJUSTABLE ROLL Ø 170 • BACK COVER INSPECTION • STONEGUARD RUBBERS • LEVELING BRACKET SIDE TRACTOR • CARDAN

CARACTERISTIQUES TECHNIQUES DE SERIE: BROYEUR POUR COUPER L'HERBE, BROYER LES CANNETTES, LES ARBUSTES D'UN Ø MAX. DE 6-8 CM SUR LES BORDURES DE ROUTE, LES TALUS ET LES FOSSÉS • GROUPE MULTIPLICATEUR EXTÉRIEUR AVEC GALET FOU • COQUE AVEC DOUBLE STRUCTURE INTERNE • DÉPLACEMENT LATÉRAL HYDRAULIQUE AVEC ARTICULATION OSCILLANTE • INCLINAISON DE LA TÊTE HYDRAULIQUE À RÉGLAGE AUTOMATIQUE DE MISE À NIVEAU • ROULEAU RÉGLABLE DE 170 DE Ø • CARTER DE VISITE ARRIÈRE • BANDES ANTI-PIERRES • ARTICULATION DE MISE À NIVEAU CÔTÉ TRACTEUR • CARDAN

CARACTERÍSTICAS TÉCNICAS DE SERIE: TRINCHADORA APTA PARA EL CORTE DE HIERBAS, TRITURACION DE CAÑEVERALES, ARBUSTOS HASTA Ø 6-8 CM EN LOS BORDOS DE CARRETERA, ORILLAS Y ZANJAS • GRUPO MULTIPLICADOR EXTERNO CON RUEDA LIBRE • BASTIDOR CON ESTRUCTURA DOBLE INTERNA • DESPLAZAMIENTO LATERAL HIDRAULICO CON ARTICULACION OSCILANTE • INCLINACION CABEZAL HIDRAULICO AUTONIVELANTE • RODILLO AJUSTABLE Ø 170 • COFRE DE INSPECCION TRASERO • BANDAS PROTECTORAS • ARTICULACION DE NIVELACION LADO TRACTOR • CARDAN

BRKE													
	mm	HP (min-max)	n° MF 3	n° Y410+1408	n°	Rpm	A	B	C	D	E	F	Kg
150	1490	50-60	16	32+16	4	540	790	710	1500	1810	2500	2030	590
175	1740	60-70	18	36+18	4	540	790	960	1700	1810	2750	2030	625
200	1990	70-80	20	40+20	4	540	790	1210	2000	1810	3000	2030	700



Sede principale • Headquarters • Siège social • Hauptsitz • Sede



Imola



España



USA



Portugal



PROJET Italia

S.S. 7 TER Km 20 + 300 Zona Industriale
74024 Manduria (Taranto) - ITALY
tel. (+39) 099 9739543 - fax (+39) 099 9738555
www.progroup.it - projet@progroup.it



PROJET Imola

Via Molino Rosso 10/C Zona Industriale
40026 Imola (Bologna) - ITALY
tel. (+39) 0542 640577 - fax (+39) 0542 640677
www.progroup.it - projet@progroup.it



PROJET España

Poligono Industrial Domenys II Avda, Tarragona 144-146
08720 Vilafranca del Penedes - BARCELONA - ESPAÑA
tel. (+34) 0938 199247 - fax (+34) 0938 199248
www.progroup.it - espana@progroup.it



PROJET Portugal

I.C. 2 - Z.I. da Santeira, 2
2480112 PEDREIRAS - PORTUGAL
tel. (+351) 0244 479140 - fax (+351) 0244 471124
www.progroup.it - portugal@progroup.it