



# PROJET

AGRICULTURE



## Un mondo di soluzioni

A lot of solutions - Un monde de solutions - Viele Lösungen - Un mónton de soluciones

[www.progroup.it](http://www.progroup.it)

**pro**  
GROUP



# PRO

## AGRI

### Un mondo d

A lot of solutions - Un monde de solutions - V

# PROFESSION

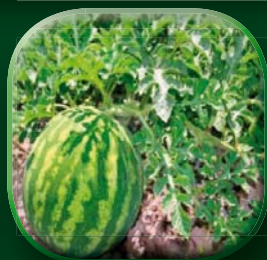

# ET

## AGRICULTURE

### Multi soluzioni

Miele Lösungen - Un mónon de solucíones

# AGRICULTURE

## PROFESSIONAL LINE

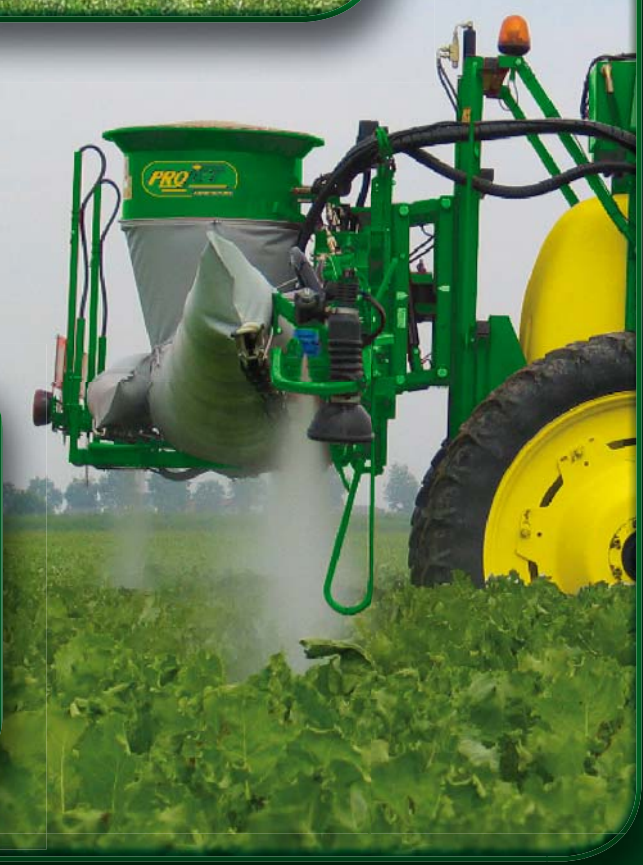



1

Gruppi portati da 100 a 1500 litri con barre da 6 a 30 metri

Mounted sprayer from 100 lt to 1500 lt with booms from 6 m to 30 m

Pulvérisateurs portés de 100 à 1500 L avec rampes de 6 à 30 m

Anbauspritzen von 100 lt bis 1500 lt mit Gestänge von 6 m bis 30 m

Pulverizadores suspendidos de 100 lt a 1500 lt con barras de 6 m a 30 m

- POMPA A MEMBRANA
- DIAPHRAGM PUMPS
- POMPE A MEMBRANES
- MEMBRANPUMPE
- BOMBAS MEMBRANA



2

- DISTRIBUTORI MANUALI
- MANUAL CONTROL UNITS
- GROUPE DE COMMANDES
- MECHANISCH ARMATUR
- GRUPOS MANUAL



2

- DISTRIBUTORI ELETTRICI
- ELECTRIC CONTROL UNITS
- GROUPE DE COMMANDES
- ELEKTRISCH ARMATUR
- GRUPOS ELÉCTRICOS



2

- COMPUTER STANDARD
- STANDARD COMPUTER
- ORDINATEUR STANDARD
- STANDARD COMPUTER
- ORDENADOR STANDARD



2

- COMPUTER PROJET
- PROJET COMPUTER
- ORDINATEUR PROJET
- PROJET COMPUTER
- ORDENADOR PROJET

*Mixer BDX*  
(660-880-1100-1300)  
(12-15m)

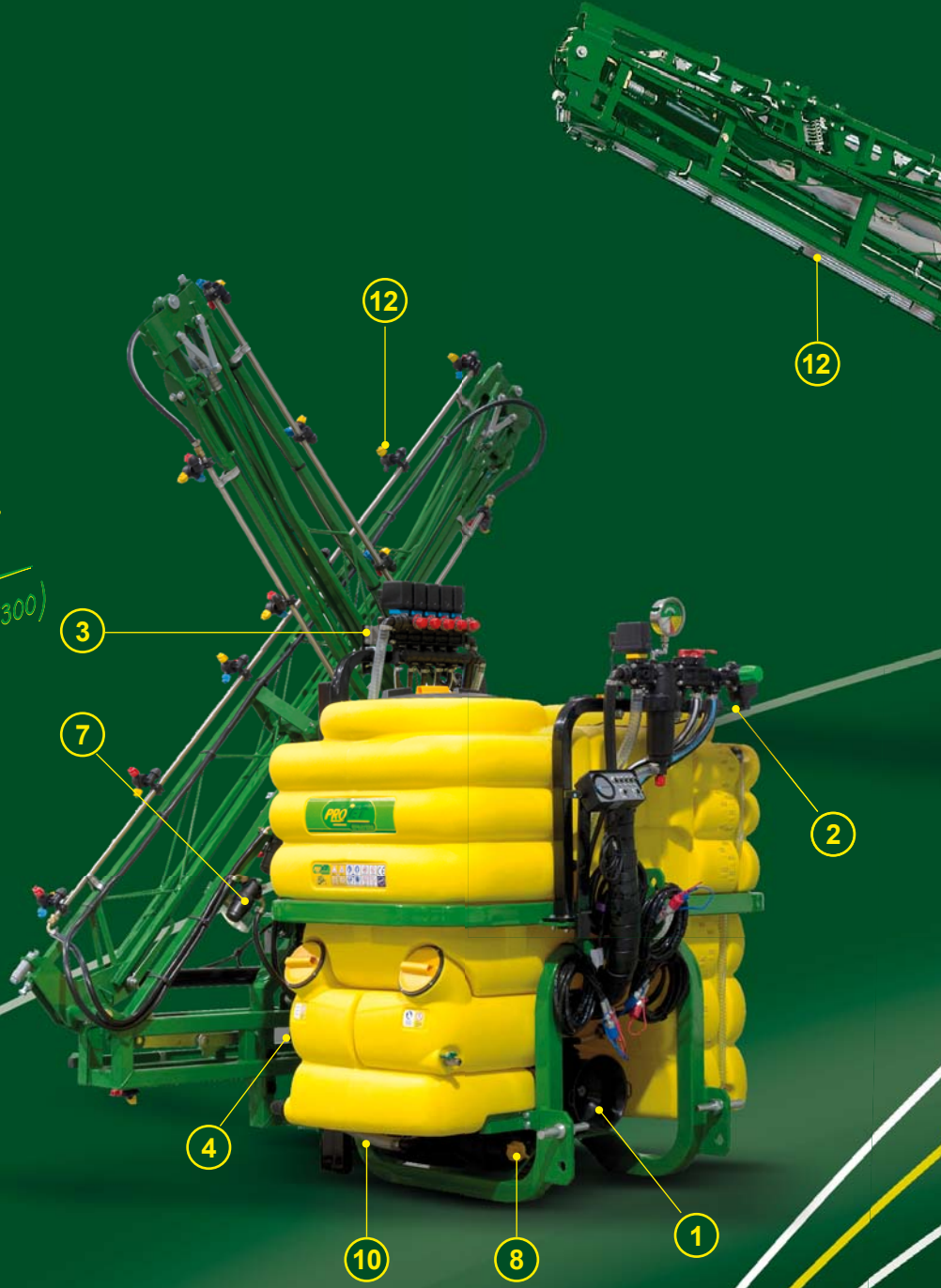

2

- COMPUTER ISOBUS
- ISOBUS COMPUTER
- ORDINATEUR ISOBUS
- ISOBUS COMPUTER
- ORDENADOR ISOBUS



2

- GUIDA SATELLITARE
- PARALLEL GUIDANCE SYSTEM
- SYSTEME SATELLITAIRE
- KOMPAKTE SPURFÜHRUNG
- CONDUCCIÓN DE SATELITE



3

- ELETTRIVALVOLE
- ELECTROVALVES
- ELECTROVANNES
- ELEKTROVENTILE
- ELECTROVÁLVULAS



4

- EQUILIBRATORI A BIELLE
- SELF LEVELLING DEVICES
- BALANCIERS
- TRAPEZ-PENDELAUSGLEICH
- EQUILIBRADOR PARA BIELAS



# PRO

AGRI

*Mixer  
BDL Air*  
(880-1100-1300)  
(12-15-16-18-18,5-20-21 m)

## Un mondo

A lot of solutions - Un monde de solutions

# PROFESS

Dotazioni e accessori

Equipment and accessories

Equipements



**SOSPENSIONI PARALLELOGRAMMA**  
 PARALLELOGRAM SUSPENSIONS  
 SUSPENSIONS A PARALLELOGRAMME  
 LUFTGEFEDERTE PARALLELOGRAMM  
 SUSPENSIONES DE PARALELOGRAMO



**SOLLEVAMENTI**  
 HEIGHT ADJUSTMENTS  
 RELEVAGES  
 HÖHENVERSTELLUNG  
 LEVANTAMIENTOS



**PISTONE INCL. BARRA**  
 TILT RAM  
 CORRECTEUR DES DEVERS  
 HANGANPASSUNGSZYLINDER  
 PISTÓN DE INCLINACIÓN



**TUBO PESCAGGIO CON FILTRO**  
 TANK FILLING UNIT  
 TUYAU D'ASPIRATION  
 BEHÄLTERFÜLLER  
 TUBO DE CARGADOR



**AVVOLGITUBO**  
 HOSE REEL KIT  
 ENROULEUR DE TUYAU  
 SCHLAUCHHASPEL  
 ARROLADOR DE TUBO



# di soluzioni

Viele Lösungen - Un montón de soluciones

# IONAL LINE

*Lord BDLA*  
(2200-2700)  
(15-16-18-18,5-20-21 m)

*Lord BDL Air*  
(2200-2700)  
(15-16-18-18,5-20-21 m)

et accessoires

Ausrüstung und Zubehör

Equipos y accesorios



RUBINETTI FILTRO LAVACIRCUITO  
 SYSTEM WASHING KIT  
 CUVE DE RINCAGE  
 SYSTEMSPÜLUNG  
 SISTEMA DE LAVADO



MIXER  
 MIXER  
 MELANGEUR  
 EINSPULSCHLEUSE  
 PREMEZCLADOR



GETTI-PORTAGETTI  
 NOZZLES / NOZZLE HOLDER  
 BUSES / PORTEBUSES  
 DÜSEN / DÜSENTRÄGER  
 BOQUILLAS / PORTABOQUILLAS



UGELLI TEEJET  
 TEEJET NOZZLES  
 BEC TEEJET  
 TEEJET DÜSEN  
 BOQUILLAS TEEJET



TRACCIAFILE  
 FOAM MARKER  
 TRACEUR A MOUSSE  
 SCHAUMMARKIERER  
 MARCADOR DE ESPUMA

**IT** Carribotte trainati da 1500 a 6000 litri con barre da 12 a 42 metri

**UK** Trailed sprayers from 1500 lt to 6000 lt with booms from 12 m to 42 m

**FR** Pulvérisateurs trainés de 1500 à 6000 L avec rampes de 12 m à 42 m

**DE** Anhänger spritzen von 1500 lt bis 6000 lt mit Gestänge von 12 m bis 42 m

**ES** Pulverizadores arrastrados de 1500 lt a 6000 lt con barras de 12 m a 42 m



**IT** KIT FRENO TIMONE SNODATO  
**UK** BRAKES FOR TRACKING DRAWBAR  
**FR** FREIN POUR FLECHE SUIVEUSE  
**DE** BREMSE FÜR LENKDEICHSEL  
**ES** FRENO PARA TIMÓN GIRATORIO



**IT** TIMONE SNODATO ATTACCO BRACCI  
**UK** TRACKING DRAWBAR, HITCHED TO ARMS  
**FR** FLECHE SUIVEUSE AVEC ATTELAGE SUR BRAS  
**DE** LENKDEICHSEL, ANSCHLUSS AN DIE HUBARME  
**ES** TIMÓN GIRATORIO, ENGANCHE A LOS BRAZOS



**IT** TIMONE STERZ. REG. ELETTR.  
**UK** ELECTR. STEERING DRAWBAR  
**FR** FLECHE SUIVEUSE ÉLECTR.  
**DE** ELEKR. LENKDEICHSEL  
**ES** TIMÓN GIRATORIO ELECTR.



**IT** TIMONE STERZ. CON INCLIN.  
**UK** STEERING DRAWBAR  
**FR** FLECHE SUIVEUSE  
**DE** LENKDEICHSEL  
**ES** TIMÓN GIRATORIO

14



**IT** LUCI CIRCOLAZIONE STRADALE  
**UK** LIGHT SET WITH PANELS  
**FR** INSTALLATION ÉCLAIRAGE  
**DE** BELEUCHTUNG MIT WARNTAFEL  
**ES** PANEL TRASERO DE LUCES



**IT** FRENI AD ARIA  
**UK** AIR BRAKE KIT  
**FR** FREIN A AIR  
**DE** LUFTBREMSEN  
**ES** FRENOS CON AIRE



**IT** FRENI IDRAULICI  
**UK** HYDRAULIC BRAKE KIT  
**FR** FREIN HYDRAULIQUE  
**DE** HYDR. BREMSEN  
**ES** FRENOS HIDRAULICOS

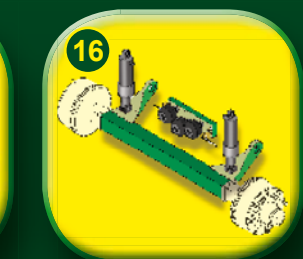

**IT** ASSALE AMM. IDRAULICO  
**UK** HYDR. SHOCK ABSORBING AXLE  
**FR** AMORTISSEURS HYDR. SUR ESSIEU  
**DE** HYDR. GELENKACHSE  
**ES** EJE AMORTIGUADO HIDRÁULICO



**IT** TIMONE FISSO ATTACCO ALTO  
**UK** FIXED DRAWBAR HIGH CONNECTION  
**FR** TIMON FIXE ATTACHE HAUTE  
**DE** STARRDEICHSEL HOHER ANSCHLUSS  
**ES** TIMÓN FIJO ENGANCHE ALTO

**IT** I dati e le descrizioni del presente opuscolo hanno soltanto valore indicativo.  
**UK** The specifications and descriptions in the brochure are purely indicative.  
**FR** Les données et les caractéristiques de cette brochure ne sont fournies qu'à titre indicatif.  
**DE** Broschüre Aufgeführten Daten und Merkmale gelten als Richtlinie.  
**ES** Los datos y las descripciones del presente folleto tienen solamente valor indicativo y podran ser cambiados sin previo aviso.

# PROJET

## AGRICULTURE

### Un mondo di soluzioni

A lot of solutions - Un monde de solutions - Viele Lösungen - Un mónon de solucíones



1 STANDARD  
1 STANDARD  
1 STANDARD  
1 STANDARD  
1 STANDARD



2 S-PLUS  
2 S-PLUS  
2 S-PLUS  
2 S-PLUS  
2 S-PLUS



3 PROJET  
3 PROJET  
3 PROJET  
3 PROJET  
3 PROJET



4 ECO TERMINAL  
4 ECO TERMINAL  
4 ECO TERMINAL  
4 ECO TERMINAL  
4 ECO TERMINAL



5 BASIC TERMINAL  
5 BASIC TERMINAL  
5 BASIC TERMINAL  
5 BASIC TERMINAL  
5 BASIC TERMINAL

1 SETTORI ACQUA  
1 WATER SECTIONS  
1 SECTION EAU  
1 TEILBREITEN  
1 SECTORES AGUA

1 SETTORI IDRAULICI  
1 HYDRAULIC SECT.  
1 SECT. HYDRAULIQUES  
1 HYDRAULISCHE SEKT.  
1 SECT. HIDRÁULICOS

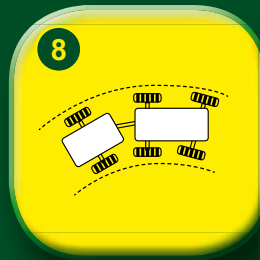

8 CONTROLLO STERZO  
8 STEERING CONTROL  
8 CONTRÔLE DE LA DIRECTION  
8 LENKUNGSKONTROLLE  
8 CONTROL DIRECCIÓN



9 GUIDA GPS CON MAPPA  
9 GPS DRIVING AND MAPPING  
9 CONDUITE GPS AVEC MAPPAGE  
9 GPS MIT KARTE  
9 CONDUCCIÓN GPS CON MAPAS



10 CONTROLLO AUT. OFF ACQUA  
10 AUTOMATIC WATER SWITCH-OFF  
10 CONTRÔLE COUPE EAU AUTOM.  
10 AUTOMATISCHE AUSSCHALTUNG  
10 APAGAMENTO AUTOMÁTICO AGUA

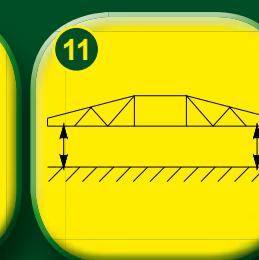

11 LIVELL. ELETTRONICO BARRA  
11 ELECTRONIC BOOM LEVELING  
11 NIVELLEMENT ÉLECTRONIQUE RAMPE  
11 ELEKTR. GESTÄNGENIVELLIERUNG  
11 NIVELACIÓN ELECTRONICA BARRA

1	n. 7	-				
2	n. 7	n. 4				
3	n. 9	n. 9				
4	n. 9	n. 11	8			11
5	n. 9	n. 11	8	9	10	11
6	n. 13	n. 11	8	9	10	11
7	n. 13	n. 11	8	9	10	11



6 TERMINALE ISOBUS  
6 ISOBUS TERMINALS  
6 TERMINALES ISOBUS  
6 ISOBUS BEDIENEINHEITEN  
6 TERMINALES ISOBUS



17 MAPPA STRADE INTERPODERALI  
17 FARM AREA MAP  
17 MAPPAGE DES CHEMINS RURAUX  
17 LANDSTRABENKARTE  
17 MAPAS CALLES INTERPODERALES



18 FARM PILOT SYSTEM  
18 FARM PILOT SYSTEM  
18 SYSTÈME FARM PILOT  
18 FARM PILOT SYSTEM  
18 FARM PILOT SYSTEM



19 TRASMISSIONE DATI ISO VIA USB  
19 ISO DATA TRANSMISSION VIA USB  
19 TRANSFER DONNÉES ISO PAR USB  
19 DATENÜBERTRAGUNG ISO DURCH USB  
19 TRANSMISIÓN DATOS ISO MEDIANTE USB



20 GESTIONE GETTI MULTIFUNZIONE  
20 CONTROL OF MULTIFUNCTIONAL JETS  
20 GESTION DES JETS MULTIFONCTION  
20 KONTROLLE VON MULTIFUNKTIONALEN DÜSEN  
20 GESTIÓN BOQUILLAS MULTIFUNCIÓN



# PROFESSIONAL LINE



- BASIC Terminal ISOBUS
- BASIC Terminal ISOBUS
- BASIC Terminal ISOBUS
- BASIC Terminal ISOBUS
- BASIC Terminal ISOBUS



- COMFORT Terminal ISOBUS
- COMFORT Terminal ISOBUS
- COMFORT Terminal ISOBUS
- COMFORT Terminal ISOBUS
- COMFORT Terminal ISOBUS

LO SPRAY COMPUTER CONSENTE ALL'OPERATORE DI VISUALIZZARE LE SEGUENTI INFORMAZIONI:

- litri per ettaro in distribuzione
- litri al minuto in erogazione
- litri parziali distribuiti
- litri totali distribuiti
- area parziale trattata
- area totale trattata
- velocità di avanzamento
- distanza totale percorsa

THE SPRAY COMPUTER SHOWS THE FOLLOWING DATA:

- spray liquid liter/hectare
- spray liquid liter/minute
- spray liquid liters
- total spray liquid liters
- treated area
- total treated area
- current speed
- total covered distance

LE SPRAY COMPUTER PERMET À L'UTILISATEUR LA VISUALISATION DES FONCTIONS SUIVANTES:

- litres/hectares en distribution
- litres/minute en distribution
- litres partiels pulvérisés
- litres totales pulvérisés
- surface partielle traitée
- surface totale traitée
- vitesse d'avancement
- distance totale parcourue

DURCH DEN COMPUTER WERDEN FOLGENDE INFORMATIONEN ANGEZEIGT:

- Ausbringung in l/Ha
- Ausbringung in l/Min
- Ausbringung in l
- Teilmenge in l
- Bearbeitete Teilbreite
- Bearbeitete Gesamtbreite
- Geschwindigkeit
- Zurückgelegte Strecke

EL ORDENADOR "SPRAY COMPUTER" VISUALIZA LAS SIGUIENTES INFORMACIONES PARA EL OPERADOR:

- litros por hectárea
- litros por minuto
- litros parciales distribuidos
- litros totales distribuidos
- área parcial tratada
- área total tratada
- velocidad de avance
- distancia total recorrida



- USB DATA
- USB DATA
- USB DATA
- USB DATA
- USB DATA



- TELEC. CONTROLLO LAVORO ANALOG CAMERA
- CAMÉRA CONTRÔLE DU TRAVAIL
- KAMERA ZUR ARBEITSKONTROLLE
- TELECAMARA CONTROL TRABAJO



- DISPLAY A COLORI COLOR DISPLAY
- ÉCRAN EN COULEURS
- FARBIGES DISPLAY
- PANTALLA DE COLORES



- JOYSTICK CONTROLLO FUNZ. JOYSTICK FUNCTIONS
- JOYSTICK POUR LE CONTRÔLE
- JOYSTICK ZUR KONTROLLE
- JOYSTICK CONTROL FUNCIONES



- PULSANTIERA SEP. CONTR. ACQUA SEPARATE KEYBOARD WATER CONTROL
- TABLEAU COMMANDE EAU SÉPARÉE
- SEPARATEKNÖPFE ZUR WASSERKONTROLLE
- MANDOS SEPARADOS CONTROL AGUA

			15	16
• 12	13	• 14	15	16
• 12	13	• 14	15	16
• 12	13	• 14	15	16

● STANDARD

**DISTANCE Control**

Work mode :

Work height : 44cm

Sprayer off height: 44cm

- TRAMITE SENSORE COLLEGATO AL COMPUTER RILEVA LA DISTANZA TRA LA BARRA E IL TERRENO
- BOOM DISTANCE FROM THE GROUND IS DETECTED BY A SENSOR CONNECTED TO THE COMPUTER
- LE CAPTEUR CONNECTÉ À L'ORDINATEUR DÉTECTE LA DISTANCE ENTRE LA RAMPE ET LE TERRAIN
- ÜBER EINEN AN DEN COMPUTER ANGESCHLOSSENEN SENSOR ERFASST SIE DEN ABSTAND ZWISCHEN GESTÄNGE UND BODEN
- MEDIANTE EL SENSOR CONECTADO AL ORDENADOR, DETECTA LA DISTANCIA ENTRE LA BARRA Y EL TERRENO



- TRACK GUIDE CON MAPPATURA
- TRACK GUIDE WITH MAPS
- TRACK GUIDE AVEC MAPPAGE
- TRACK GUIDE MIT KARTEN
- TRACK GUIDE CON MAPAS



- QUADRO GUIDA SATELLITARE CON ANTENNA ESTERNA
- SATELLITE GUIDE MONITOR WITH EXTERNAL RECEIVER
- GUIDAGE SATELLITAIRE AVEC ANTENNE EXTERIEURE
- BILDSCHIRM SATELLIT MIT AUBENANTENNE
- PANELES DE GUÍA DE SATELITE CON ANTENA EXTERNA

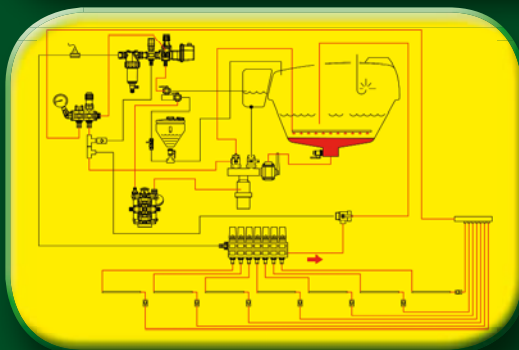

### IMPIANTO ACQUA STANDARD

L'impianto acqua "tradizionale". Completo già nella sua configurazione base. I tecnici PROJET hanno ottimizzato tubazioni e componentistica al fine di aver le migliori portate d'acqua con residui finali minimi.

### WATER SYSTEM

The standard water system, supplied already complete in its basic configuration. PROJET designers have optimised the system pipelines and componentry in order to ensure the highest water flow rates with minimised final residues.

### SYSTÈME HYDRIQUE

Le système hydrique "traditionnel", déjà complet dans sa configuration standard. Les techniciens PROJET ont optimisé les tuyaux et les composants afin d'obtenir des débits d'eau optimaux avec des résidus finaux minimums.

### WASSERANLAGE

Die „traditionelle“ Wasseranlage, die bereits in ihrer Grundausstattung komplett ist. Die Techniker PROJET haben die Rohrleitungen und Bestandteile derart optimiert, dass der bestmögliche Wasserdurchfluss bei minimalem Rückstandvorkommen erreicht wird.

### INSTALCIÓN DEL AGUA

La instalación del agua "tradicional". Completa ya en su configuración básica. Los técnicos PROJET optimizaron las tuberías y los componentes para tener mejores caudales de agua con residuos finales mínimos.

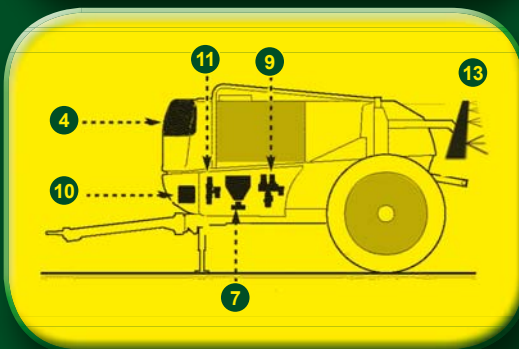

### IMPIANTO ACQUA OPTIONAL

- 1 Pompa riempibotte
- 2 Lava cisterna
- 3 Impianto agitazione
- 4 Cist. acqua chiara
- 5 Valvola regol. generale
- 6 Manometri
- 7 Mixer
- 8 Lavaggio attrezzatura
- 9 Rubinetteria principale
- 10 Pompa a membrana
- 11 Valvole settoriali
- 12 Filtri in linea
- 13 Barra

### OPTIONAL

- 1 Sprayer filler pump
- 2 Tank washer
- 3 Stirring system
- 4 Clean water tank
- 5 Main control valve
- 6 Pressure gauges
- 7 Mixer
- 8 Equipment washing
- 9 Main taps and valves
- 10 Diaphragm pump
- 11 Sector valves
- 12 In-line filters
- 13 Boom

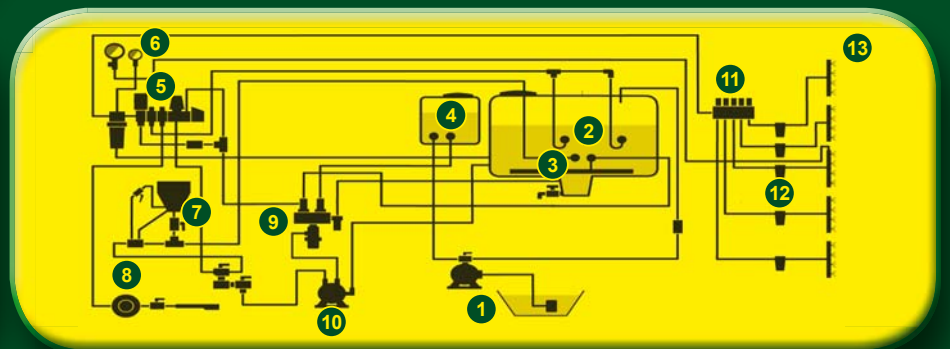

### OPTIONAL

- 1 Pompe de remplissage cuve
- 2 Rinçage cuve
- 3 Système d'agitation
- 4 Réservoir d'eau claire
- 5 Soupape de réglage général
- 6 Manomètres
- 7 Mélangeur
- 8 Rinçage équipement
- 9 Robinets principaux
- 10 Pompe à membrane
- 11 Soupapes secteurs
- 12 Filtres en ligne
- 13 Rampes

### OPTIONAL

- 1 Behälterfüllerpumpe
- 2 Tankreinigungs-vorrichtung
- 3 Rühranlage
- 4 Reinwassertank
- 5 Haupteinstellungsventil
- 6 Manometer
- 7 Einspülschleuse
- 8 Gerätereinigungsvorrichtung
- 9 Hauptarmaturen
- 10 Membranpumpe
- 11 Sektorventile
- 12 Leitungsfiler
- 13 Gestängen

### OPTIONAL

- 1 Bomba de llenado cuba
- 2 Lavado cisterna
- 3 Instalación de mezcla
- 4 Cist. agua límpida
- 5 Válvula de regul. general
- 6 Manómetros
- 7 Mezclador
- 8 Lavado equipo
- 9 Grifería principal
- 10 Bomba de membrana
- 11 Válvulas sectoriales
- 12 Filtros en línea
- 13 Barra

# PROFESSIONAL LINE



**VANTAGGI DELL'AIRASSISTED:** Possibilità di lavorare anche in presenza di vento a 6/8 m/sec. riducendo pertanto la dipendenza d'impiego della macchina ai fenomeni atmosferici. L'effetto deriva è quasi totalmente annullato riducendo del 90% nella maggior parte dei casi di trattamento. La spinta dell'aria sino a 32 m/sec. permette una buona penetrazione anche in colture alte o con fogliame molto fitto.

**AIRASSISTED ADVANTAGES:** This device makes it possible to work also in 6/8 m/sec strong winds, making the machine less dependent on surrounding weather conditions. Drift is minimised to virtually zero levels (reduced by 90% in most treatment cases). An air thrust up to 32 m/sec ensures good penetration also in tall crops or thick foliage crops.

**AIRASSISTED ADVANTAGES:** Possibilità di lavorare anche in presenza di vento a 6/8 m/sec. en réduisant, donc, les limites d'emploi dues aux conditions atmosphériques. L'effet "dérive" est presque entièrement annulé (et réduit de 90% dans la plupart des cas). La poussée de l'air jusqu'à 32 m/sec. garantit une bonne pénétration même en cas de cultures hautes ou de feuillage très épais.

**AIRASSISTED VORTEILE:** Möglichkeit, auch bei Wind mit 6/8 m/sek. zu arbeiten; dies reduziert die Einsatzabhängigkeit des Geräts von Witterungsverhältnissen. Die Abdrifttendenz ist durch die Reduzierung um 90 % bei den meisten Behandlungen fast völlig aufgehoben. Der Luftschub bis 32 m/sek. gewährleistet ein gutes Durchdringen selbst hoher Kulturen oder solcher mit dichtem Laubwerk.

**AIRASSISTED VENTAJAS:** Posibilidad de trabajar incluso en caso de viento de 6/8 m/seg. reduciendo así la dependencia del uso de la máquina de los fenómenos atmosféricos. El efecto deriva se anula casi completamente con una reducción igual al 90% en la mayoría de los casos de tratamiento. El empuje del aire hasta 32 m/seg. permite una buena penetración incluso en cultivos altos o con follaje muy espeso.



**Doppia turbina per barre da 28 a 30 metri**  
**Twin turbine for 28 to 30 metre booms**  
**Turbine double pour rampes de 28 à 30 mètres**

**Doppelturbine für Gestänge von 28 bis 30 Meter Länge**  
**Doble turbina para barras de 28 a 30 metros**

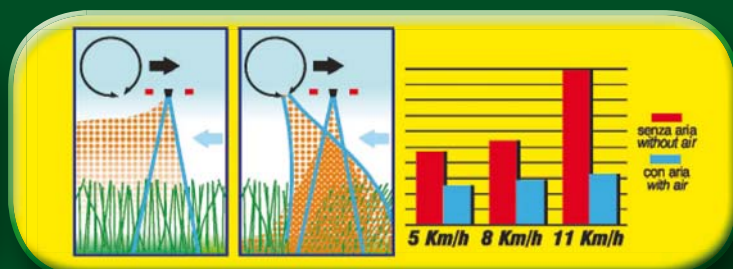

**Effetto dell'AIRASSISTED sulla deriva**  
**AIRASSISTED effect on drift**  
**Effet du système AIRASSISTED sur la dérive**

**Wirkung des AIRASSISTED auf die Abdrifttendenz**  
**Efecto del AIRASSISTED sobre la deriva**



**SERBATOIO OLIO BDLA PLUS**  
**BDLA PLUS OIL TANK**  
**RÉSERVOIR D'HUILE BDLA PLUS**  
**BDLA PLUS ÖLTANK**  
**TANQUE ACEITE BDLA PLUS**



**SERBATOIO OLIO BDLA**  
**BDLA OIL TANK**  
**TANQUE ACEITE BDLA**  
**ÖLTANK BDLA**  
**TANQUE ACEITE BDLA**



**FILTRO CON MANOMETRO**  
**FILTER WITH PRESSURE GAUGE**  
**FILTRE AVEC MANOMÈTRE**  
**FILTER MIT MANOMETER**  
**FILTRO CON MANÓMETRO**



**RADIATORE TURBINA BDLA**  
**BDLA TURBINE COOLER**  
**BDLA RADIATEUR TURBINE**  
**BDLA TURBINENKÜHLER**  
**RADIATORE TURBINA BDLA**

# Un mondo di soluzioni

A lot of solutions - Un monde de solutions - Viele Lösungen - Un móniton de solucióes

# PROJET

## AGRICULTURE

Mixer  
BDI



Mixer	It	B	C	A	BDI		
					12	15	
660	600				A (mm)	2450	3000
					B (mm)	1720	1720
					C (mm)	1860	1860
					Kg	450	480
880	800				A (mm)	2450	3000
					B (mm)	1880	1880
					C (mm)	2060	2060
					Kg	525	555
1100	1000				A (mm)	2450	3000
					B (mm)	1880	1880
					C (mm)	2060	2060
					Kg	530	560
1300	1200				A (mm)	2450	3000
					B (mm)	1880	1880
					C (mm)	2060	2060
					Kg	535	565

Mixer  
BDX



Mixer	It	B	C	A	BDX		
					12	15	
660	600				A (mm)	2500	2500
					B (mm)	1410	1410
					C (mm)	2700	3180
					Kg	455	485
880	800				A (mm)	2500	2500
					B (mm)	1570	1570
					C (mm)	2700	3180
					Kg	530	555
1100	1000				A (mm)	2500	2500
					B (mm)	1570	1570
					C (mm)	2700	3180
					Kg	535	565
1300	1200				A (mm)	2500	2500
					B (mm)	1570	1570
					C (mm)	2700	3180
					Kg	540	570

# PROFESSIONAL LINE

Mixer  
BDU



🇮🇹 Gruppi diserbo portati

🇬🇧 Mounted sprayer

🇫🇷 Pulvérisateurs portés

🇩🇪 Anbauspritzen

🇪🇸 Pulverizadores suspendidos

Mixer	It	C A	BDU		
			15	16	18
880	800	A (mm)	2500	2500	2500
		B (mm)	1900	1900	1900
		C (mm)	2850	2850	2850
		Kg	820	825	845
1100	1000	A (mm)	2500	2500	2500
		B (mm)	1900	1900	1900
		C (mm)	2850	2850	2850
		Kg	830	835	855
1300	1200	A (mm)	2500	2500	2500
		B (mm)	1900	1900	1900
		C (mm)	2850	2850	2850
		Kg	840	845	865

Mixer  
BDL



Mixer	It	C A	BDL					
			15	16	18	20	21	24
880	800	A (mm)	2480	2480	2480	2480	2480	2480
		B (mm)	3680	3680	4250	4870	4870	5500
		C (mm)	3020	3020	3230	3550	3550	3630
		Kg	801	801	830	924	925	1010
1100	1000	A (mm)	2480	2480	2480	2480	2480	2480
		B (mm)	3680	3680	4250	4870	4870	5500
		C (mm)	3020	3020	3230	3550	3550	3630
		Kg	811	822	840	934	935	1020
1300	1200	A (mm)	2480	2480	2480	2480	2480	2480
		B (mm)	3680	3680	4250	4870	4870	5500
		C (mm)	3020	3020	3230	3550	3550	3630
		Kg	821	822	850	944	945	1030

# Un mondo di soluzioni

A lot of solutions - Un monde de solutions - Viele Lösungen - Un móniton de solucióes



Royal	lit	A B C	BDM			
			15	16	18	20
1700	1500	A (mm)	3000	3000	3000	3000
		B (mm)	4450	4450	4450	4450
		C (mm)	2430	2430	2430	2430
		<b>Kg</b>	1150	1157	1164	1171
2200	2000	A (mm)	3000	3000	3000	3000
		B (mm)	4450	4450	4450	4450
		C (mm)	2430	2430	2430	2430
		<b>Kg</b>	1180	1187	1194	1201
2700	2500	A (mm)	3000	3000	3000	3000
		B (mm)	4450	4450	4450	4450
		C (mm)	2490	2490	2490	2490
		<b>Kg</b>	1220	1227	1234	1241

Royal  
BDM



Royal  
BDX



Royal	lit	A B C	BDX	
			12	15
1700	1500	A (mm)	2500	2500
		B (mm)	4260	4260
		C (mm)	2900	3380
		<b>Kg</b>	1090	1120
2200	2000	A (mm)	2500	2500
		B (mm)	4260	4260
		C (mm)	2900	3380
		<b>Kg</b>	1120	1150
2700	2500	A (mm)	2500	2500
		B (mm)	4260	4260
		C (mm)	2900	3380
		<b>Kg</b>	1160	1190

# PROFESSIONAL LINE

Royal	lit	A B C	BDL				
			15	16	18	20	21
1700	1500	A (mm)	2530	2530	2530	2530	2530
		B (mm)	4350	4350	4530	4870	4870
		C (mm)	2940	2940	3150	3470	3470
		Kg	1391	1392	1420	1544	1545
2200	2000	A (mm)	2530	2530	2530	2530	2530
		B (mm)	4350	4350	4530	4870	4870
		C (mm)	2940	2940	3150	3470	3470
		Kg	1421	1422	1450	1574	1575
2700	2500	A (mm)	2530	2530	2530	2530	2530
		B (mm)	4350	4350	4530	4870	4870
		C (mm)	2940	2940	3150	3470	3470
		Kg	1461	1462	1490	1614	1615

 Gruppi diserbo trainati

 Trailed sprayers

 Pulvérisateurs trainés

 Anhängerspritzen

 Pulverizadores arrastrados

*Royal  
BDL*



Royal	lit	A B C	BDI	
			12	15
1700	1500	A (mm)	2470	3000
		B (mm)	4450	4450
		C (mm)	2430	2430
		Kg	1170	1200
2200	2000	A (mm)	2470	3000
		B (mm)	4450	4450
		C (mm)	2430	2430
		Kg	1200	1230
2700	2500	A (mm)	2470	3000
		B (mm)	4450	4450
		C (mm)	2490	2490
		Kg	1240	1270

*Royal  
BDI*



# Un mondo di soluzioni

A lot of solutions - Un monde de solutions - Viele Lösungen - Un mónton de solucióes



Lord	It	A B C	BDI	
			12	15
2200	2000	A (mm)	2470	3000
		B (mm)	4450	4450
		C (mm)	2432	2432
		Kg	1250	1280
2700	2500	A (mm)	2470	3000
		B (mm)	4450	4450
		C (mm)	2490	2490
		Kg	1290	1320

*Lord  
BDI*



*Lord  
BDX*



Lord	It	A B C	BDX	
			12	15
2200	2000	A (mm)	2500	2500
		B (mm)	4260	4260
		C (mm)	2900	3380
		Kg	1175	1200
2700	2500	A (mm)	2500	2500
		B (mm)	4260	4260
		C (mm)	2900	3380
		Kg	1215	1240



# PROFESSIONAL LINE

Gruppi diserbo trainati

Trailed sprayers

Pulvérisateurs trainés

Anhängespritzen

Pulverizadores arrastrados

Lord	lit	A B C	BDL					
			15	16	18	20	21	24
2200	2000	A (mm)	2530	2530	2530	2530	2530	2530
		B (mm)	4350	4350	4530	4870	4870	5500
		C (mm)	2940	2940	3150	3470	3470	3550
		Kg	1471	1472	1500	1594	1595	1680
2700	2500	A (mm)	2530	2530	2530	2530	2530	2530
		B (mm)	4350	4350	4530	4870	4870	5500
		C (mm)	2940	2940	3150	3470	3470	3550
		Kg	1511	1512	1540	1634	1635	1720

Lord  
BDL



Lord  
BDL Air



Lord	lit	A B C	BDL Air					
			15	16	18	18,5	20	21
2200	2000	A (mm)	2550	2550	2550	2550	2550	2550
		B (mm)	5050	5050	5050	5050	6100	6100
		C (mm)	3000	3000	3200	3200	3800	3800
		Kg	1688	1692	1725	1729	1817	1822
2700	2500	A (mm)	2550	2550	2550	2550	2550	2550
		B (mm)	5050	5050	5050	5050	6100	6100
		C (mm)	3000	3000	3200	3200	3800	3800
		Kg	1728	1732	1765	1769	1857	1862

# Un mondo di soluzioni

A lot of solutions - Un monde de solutions - Viele Lösungen - Un mónnton de solucíones

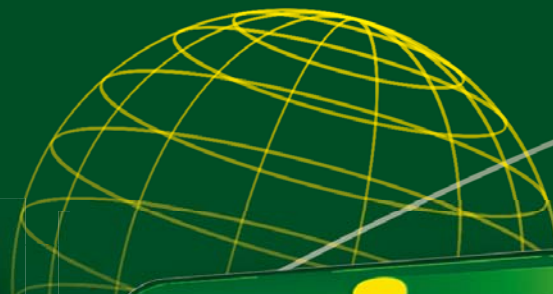

King	lit	A B C		BDL					
				18	20	21	24	27	28
3200	3000	A (mm)	2530	2530	2530	2530	2530	2530	
		B (mm)	6650	6650	6650	7150	7050	7050	
		C (mm)	3100	3420	3420	3500	3850	3850	
		Kg	3525	3617	3618	3730	4105	4106	
4200	4000	A (mm)	2530	2530	2530	2530	2530	2530	
		B (mm)	6650	6650	6650	7150	7050	7050	
		C (mm)	3100	3420	3420	3500	3850	3850	
		Kg	3575	3667	3668	3780	4155	4156	
5200	5000	A (mm)	-	2530	2530	2530	2530	2530	
		B (mm)	-	6650	6650	7150	7050	7050	
		C (mm)	-	3420	3420	3500	3850	3850	
		Kg	-	3767	3768	3855	4255	4256	

*King  
BDL*



King	lit	A B C		BDL Plus G/Var							
				24	27	28	30	32	33	36	40
3200	3000	A (mm)	2550	2550	2550	-	-	-	-	-	-
		B (mm)	6950	6950	6950	-	-	-	-	-	-
		C (mm)	3550	3900	3900	-	-	-	-	-	-
		Kg	3860	3995	4000	-	-	-	-	-	-
4200	4000	A (mm)	2550	2550	2550	2550	2550	2550	3000	3000	3000
		B (mm)	6950	6950	6950	7900	7900	7900	6700	7700	7700
		C (mm)	3550	3900	3900	3700	3700	3700	3700	3700	3700
		Kg	3910	4045	4050	4335	4367	4375	4800	5100	5120
5200	5000	A (mm)	2550	2550	2550	2550	2550	2550	3000	3000	3000
		B (mm)	6950	6950	6950	7900	7900	7900	6700	7700	7700
		C (mm)	3550	3900	3900	3700	3700	3700	3700	3700	3700
		Kg	4010	4145	4150	4435	4467	4475	4900	5200	5220



*King  
BDL Plus G/Var*

# PROFESSIONAL LINE

 Gruppi diserbo trainati

 Trailed sprayers

 Pulvérisateurs trainés

 Anhängerspritzen

 Pulverizadores arrastrados

King	It	A B C	BDL Air				
			18	18,5	20	21	24
3200	3000	A (mm)	2550	2550	2550	2550	2550
		B (mm)	7250	7250	7250	7250	7550
		C (mm)	3300	3300	3900	3900	4240
		Kg	3629	3633	3726	3731	3881
4200	4000	A (mm)	2550	2550	2550	2550	2550
		B (mm)	7250	7250	7250	7250	7550
		C (mm)	3300	3300	3900	3900	4240
		Kg	3679	3683	3776	3781	3931

*King  
BDL Air*



King	It	A B C	BDL Air Plus					
			20	21	24	27	28	30
3200	3000	A (mm)	3000	3000	3000	3000	3000	3000
		B (mm)	7400	7400	7400	7400	7400	7600
		C (mm)	3650	3650	3650	3800	3800	3800
		Kg	4415	4420	4500	4730	4735	4880
4200	4000	A (mm)	3000	3000	3000	3000	3000	3000
		B (mm)	7400	7400	7400	7400	7400	7600
		C (mm)	3650	3650	3650	3800	3800	3800
		Kg	4465	4470	4550	4780	4785	4930
5200	5000	A (mm)	3000	3000	3000	3000	3000	3000
		B (mm)	7400	7400	7400	7400	7400	7600
		C (mm)	3650	3650	3650	3800	3800	3800
		Kg	4565	4570	4650	4880	4885	5030

*King  
BDL Plus Plus*





Sede principale • Headquarters • Siège social • Hauptsitz • Sede



PROJET AGRICULTURE Imola



PROJET AGRICULTURE España



PROJET AGRICULTURE USA



PROJET AGRICULTURE Portugal



### PROJET Italia

S.S. 7 TER Km 20+300 Zona Industriale  
74024 Manduria (Taranto) - ITALY  
tel. (+39) 099 9739543 - fax (+39) 099 9738555  
www.progroup.it - projet@progroup.it



### PROJET Imola

Via Molino Rosso 10/C Zona Industriale  
40026 Imola (Bologna) - ITALY  
tel. (+39) 0542 640577 - fax (+39) 0542 640677  
www.progroup.it - projet@progroup.it



### PROJET España

Poligono Industrial Domenys II Avda, Tarragona 144-146  
08720 Vilafranca del Penedes - BARCELONA - ESPAÑA  
tel. (+34) 0938 199247 - fax (+34) 0938 199248  
www.progroup.it - espana@progroup.it



### PROJET Portugal

I.C. 2 - Z.I. da Santeira, 2  
2480112 PEDREIRAS - PORTUGAL  
tel. (+351) 0244 479140 - fax (+351) 0244 471124  
www.progroup.it - portugal@progroup.it