

# Holland Transplanter

Model 1500-1600

## Assembly & Parts Manual

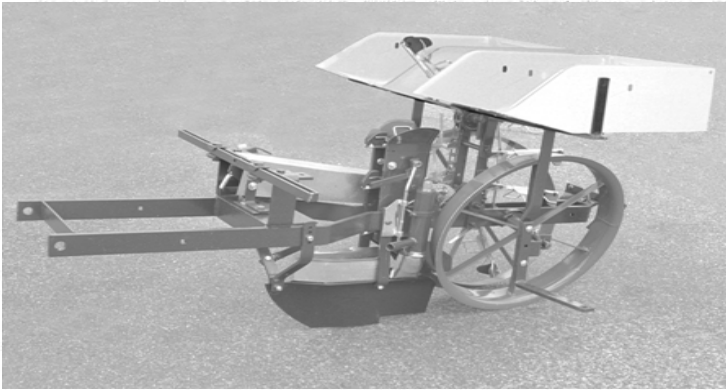

The Holland Transplanter Model 1600 is designed to give years of trouble-free planting with low maintenance cost. To keep your planter running smoothly we suggest the following.

### Before Operation

1. Grease all fittings to flush out foreign materials.

Grease fittings are found in the following locations:

- 1 - In each packing wheel
- 1 - In each unit upright brace.
- 1 - In upper conveyor pulley (chain style units only)
- 1 - Rocker arm assembly of water valve

2. Trip water valve by hand to determine if it is working freely.

3. On chain style units the plant closing guides can be adjusted to grip seedlings at different times. This allows you to vary the planting speeds. Raising the tops will grip the plants sooner, lowering will grip the plants later. Both tops must be at the same height to insure proper plant holding.

4. The furrow opener can be adjusted up or down, as well as forward and backward. When small plants are being planted, it is recommended the furrow opener be raised. With large plants the opener should be lowered. In dry, loose soil, position the furrow opener back toward the packing wheels. In heavy, moist soil the opener should be moved forward, away from the packing wheels. After adjusting the furrow opener, be sure it is in the center of the opening between the packing wheels so the plant holder travels through the middle of the open furrow.

5. With planting unit in raised position, turn the packing wheels by hand. Allow the drive chains about 1" of slack to insure the packing wheels move freely. If wheels will not turn freely, check the water trip mechanism and the

plant holders to insure they are working freely. Adjust soil scraper (on units equipped with steel packing wheels) so they are not tight against the packing wheel.

6. Check that the planting unit is secured to its mounting brackets and/or hitches by making sure all nuts, bolts, cotter pins, etc. are in place and tight. Also check that the operator's seats are securely fastened to the planting unit.

7. Your unit is designed to operate only in tilled fields. Make sure that the field is worked to a depth that is deeper than the furrow opener you will be using. This insures the planter is riding on the packing wheels, not the furrow opener, and that the soil will be properly packed around each plant.

8. Review safety warnings on page 2.

### During Operation

1. Place seedlings in the same location of the rubber gripper to insure a uniform planting depth. The depth for setting plants can be regulated by the distance the root extends out of the gripper. For deeper planting, move the plant seedling down in the rubber gripper exposing more roots. For shallower plantings, you can move the plant seedling up in the rubber gripper exposing less roots.

2. Keep furrow opener clean by removing any trash that accumulates on the front, or any soil that builds up on the sides. Failure to keep the opener clean will result in a wider furrow and poor plant coverage and spacing.

3. Do not operate transplanter backwards. This can cause damage to plant holders and plug up the furrow opener with soil.

4. The planting unit frame must run parallel to the ground surface and there must be a minimum of 1" clearance between the unit frame and the frame lifting bar.

### After Operation

1. Drain and clean thoroughly all water barrels, valves and hoses to prevent scale buildup or freezing.

2. Remove rubber grippers from the plant holders and store in a warm area with the grippers in an open position.

3. Remove all soil and debris from unit.

4. Use only Holland Transplanter approved replacement parts when making repairs. They can be obtained from Holland Transplanter Co. or from your authorized Holland Transplanter dealer. Make sure you use only parts for your specific model.





## Safety Warnings

As with most farm machinery, there is an inherent hazard when operating the machinery that cannot be totally eliminated if the product is to perform its intended function. These hazards can cause injuries to the operators. To reduce the risk of injury, follow these safety warnings.

 This symbol is a safety alert symbol and requires your attention. Be alert, your safety is involved. The possibility of a serious bodily injury or death exists. Carefully follow safety measure instructions.

 Check that the planting unit is secure to its mounting brackets and/or hitches by making sure all nuts, bolts, cotter pins, etc. are in place and tight. Also check that the operators seats are securely fastened to the planting unit.

 Only allow adults to operate the transplanter who have been trained in its use and are familiar with how to operate it safely. Never allow children to operate a transplanter.

 Do not ride on transplanter unit when it is in the raised (not planting) position.

 Do not allow anyone who is not operating the planting unit, and who is not properly seated to ride on the planting unit, its carrying toolbar or carrying mainframe.

 Keep loose clothing and hair away from all moving parts including sprockets, chains and plant holders.

 Always place feet on the unit footrest while seated in the operators seat.

 This machine is of customary S.A.E. measurement design. Use only tools of S.A.E. measurement. Metric or other tools that do not fit properly can slip and cause injury.

## Assembly Instructions

### 1. Attach the planting unit to hitch or mounting bracket.

This will vary according to what hitch or mounting bracket you are going to use. To attach the planting unit, see the instructions supplied with your hitch or mounting bracket.

### 2. Attach the plant holders to the chain.

To protect the plant holders and minimize shipping carton sizes, some or all of your plant holders may not have been attached to the chain. These plant holders must be attached before your planting unit is operational.

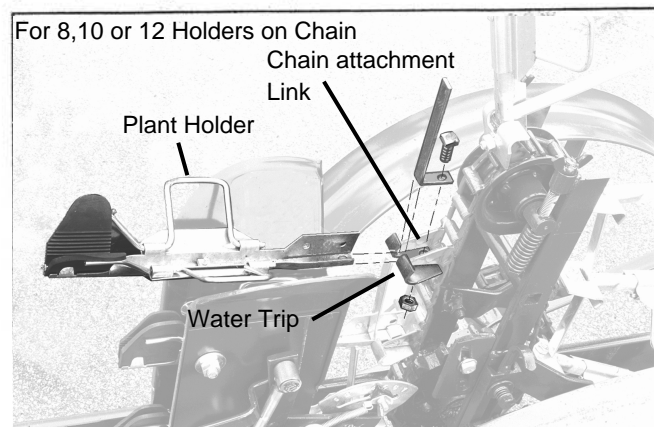

**For units using either 8, 10 or 12 plant holders on the chain, place the 5/16" x 3/4" square head bolt through the spacer and the plant holder. Then fit the plant holder into the chain attachment link. The water trip goes on the back side of the chain attachment link, with the curved cams surrounding the plant holder. Secure with the 5/16" hex nut (see illustration). Make sure the plant holder is perpendicular to the chain before tightening. The water trip is not necessary for planting units that do not have a water valve attachment. Adjust upper conveyor pulley by tightening or loosening the pulley bolts to make plant holders travel through center of closing guides. To avoid damage, never run plant holders through the guides in the reverse direction.**

**For units using 6 plant holders on the chain, place the 5/16" x 3/4" square head bolt through the plant holder fitting the holder into the chain attachment link. The water trip goes on the back side of the chain attachment link, with the curved cams surrounding the plant holder. The spacer is attached to the back side of the water trip.**

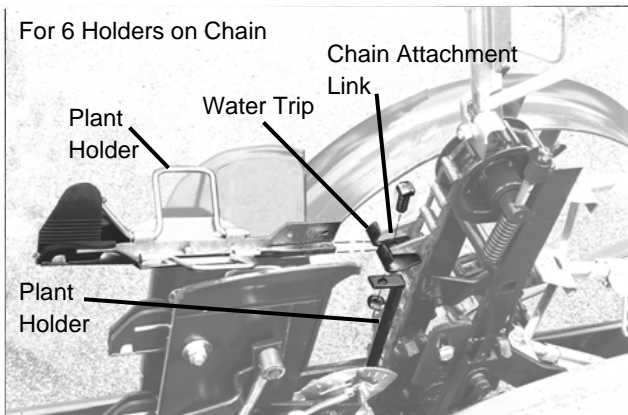

Secure with the 5/16" nut (see illustration). Make sure the plant holder is perpendicular to the chain before tightening. The water trip is not necessary for planting units that do not have a water valve attachment. Adjust upper conveyor pulley by tightening or loosening the pulley bolts to make plant holders travel through center of closing guides. To avoid damage, never run plant holders through the guides in reverse direction.

**3. Attach seats to planting unit.**

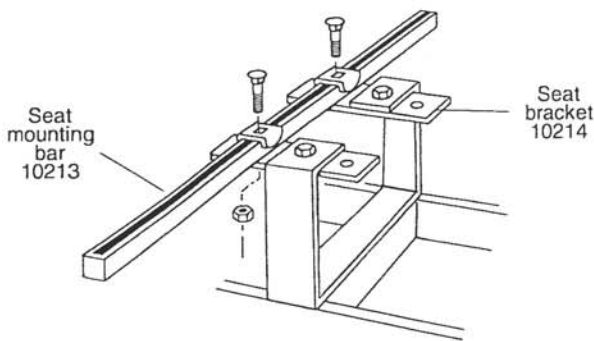

Attach the seat mounting bar (10213) to the seat bracket (10214) as shown. Secure with the 1/2" x 2" carriage bolts, bent seat washers and 1/2" nuts. The seat bracket can be adjusted forward or backward on the unit frame for maximum operator comfort. Attach the seats to the mounting bar as per the instructions supplied with the specific type of seats you purchased. Make sure all bolts and nuts are securely fastened before allowing anyone to sit on the transplanter.

**4. Attach the water hose (for planting units using a water valve)**

Attach the water hose from the water barrel to the end of the pipe located at the bottom of the valve. Place the hose end at least 1" onto the pipe and secure with the hose clamp. To allow a free flow of water, make sure the hose is not pinched anywhere between the valve and the water barrel.

**5. Attach the soil scraper (for planting units using steel packing wheels)**

Place the soil scraper on the frame at the rear of the planting unit. The blades should be pointed down with the cutouts on the blade aligning with the curved flange of the packing wheel (see illustration). Keep the soil scraper loose and flexible against the packing wheels, do not over tighten the soil scraper bolt. A tight soil scraper will bind against the packing wheels making them slide along the ground.

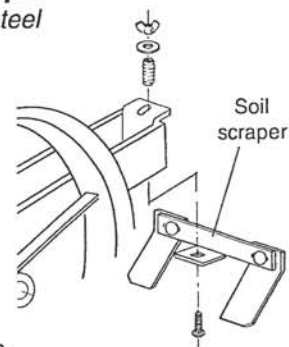

**6. Attach the plant holding boxes.**

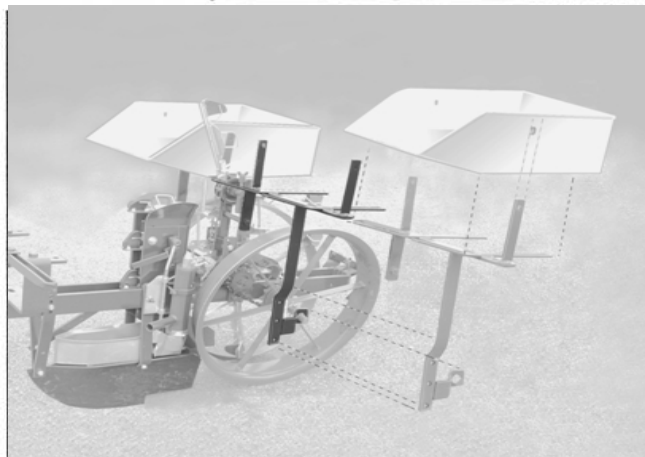

Remove the center 7/16 x 5-1/2" bolt. Leave the upright spacer between the upright brackets. Place plant box mounting stands over the packing wheel axles (see illustration) and reinsert the spacer bolt to hold the stands against the uprights. The plant holding boxes can be slid into the stands. They are held in place by the notches in the box. Attach foot rests to bottom of plant box stands.

# Transplanter Frame and Furrow Openers

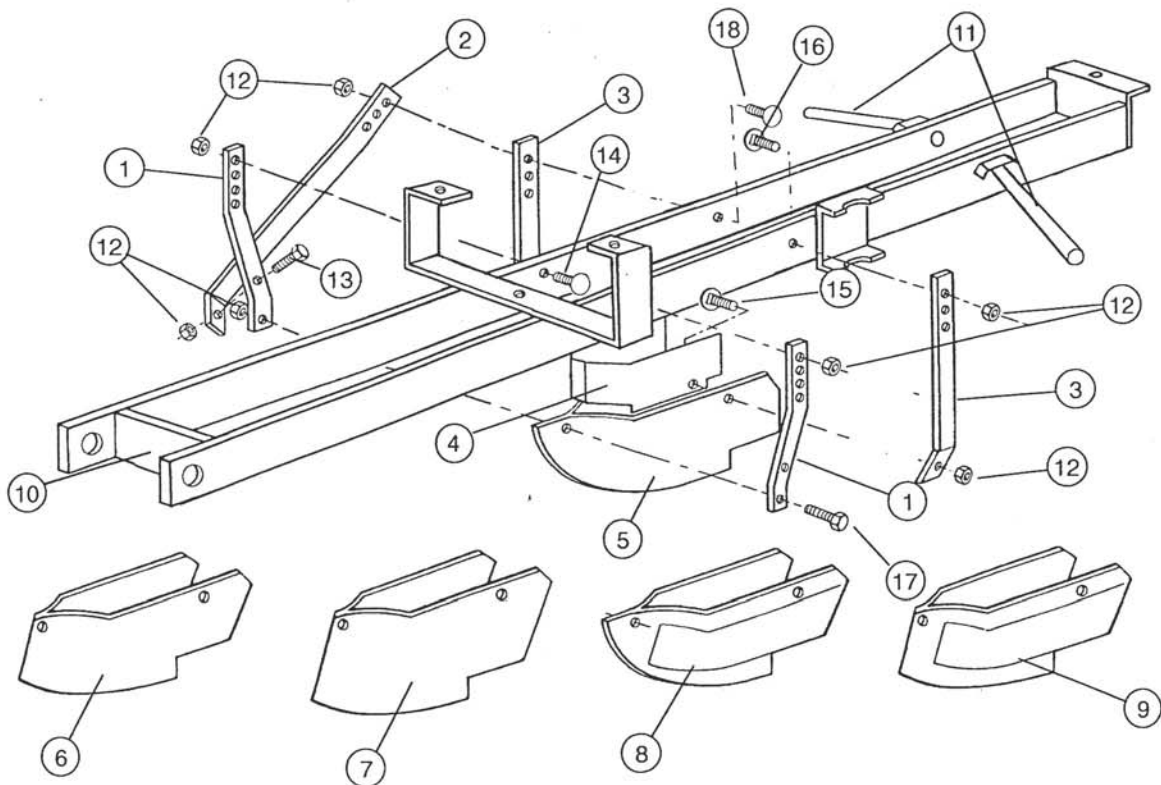

Ref #	Part #	Description
1	10203	Brace, front furrow opener
2	10205	Brace, diagonal furrow opener
3	10206	Brace, rear furrow opener
4	10207	Shield, furrow opener galvanized
5	10208	Opener, round point 7" furrow
6	10209	Opener, blunt point 7" furrow
7	10210	Opener, blunt point 10" furrow
8	10211	Opener, polymer coated round point 7" furrow
9	10212	Opener, polymer coated blunt point 7" furrow

Ref #	Part #	Description
10	10068	Frame, unit
11	10357	Axle, packing wheel
12	1480005	Nut, 3/8 hex
13	1280003	Bolt, 3/8 x 1-1/4" HHCS
14	1380005	Bolt, 3/8 x 1-1/4" carriage
15	1380003	Bolt, 3/8 x 1" carriage
16	1380008	Bolt, 3/8 x 1-1/2" carriage
17	1280032	Bolt, 3/8 x 1-1/2" HHCS
18	1380007	Bolt, 3/8 x 2" carriage

# Disc Plant Holder Arrangement

For plant spacings greater than 3"

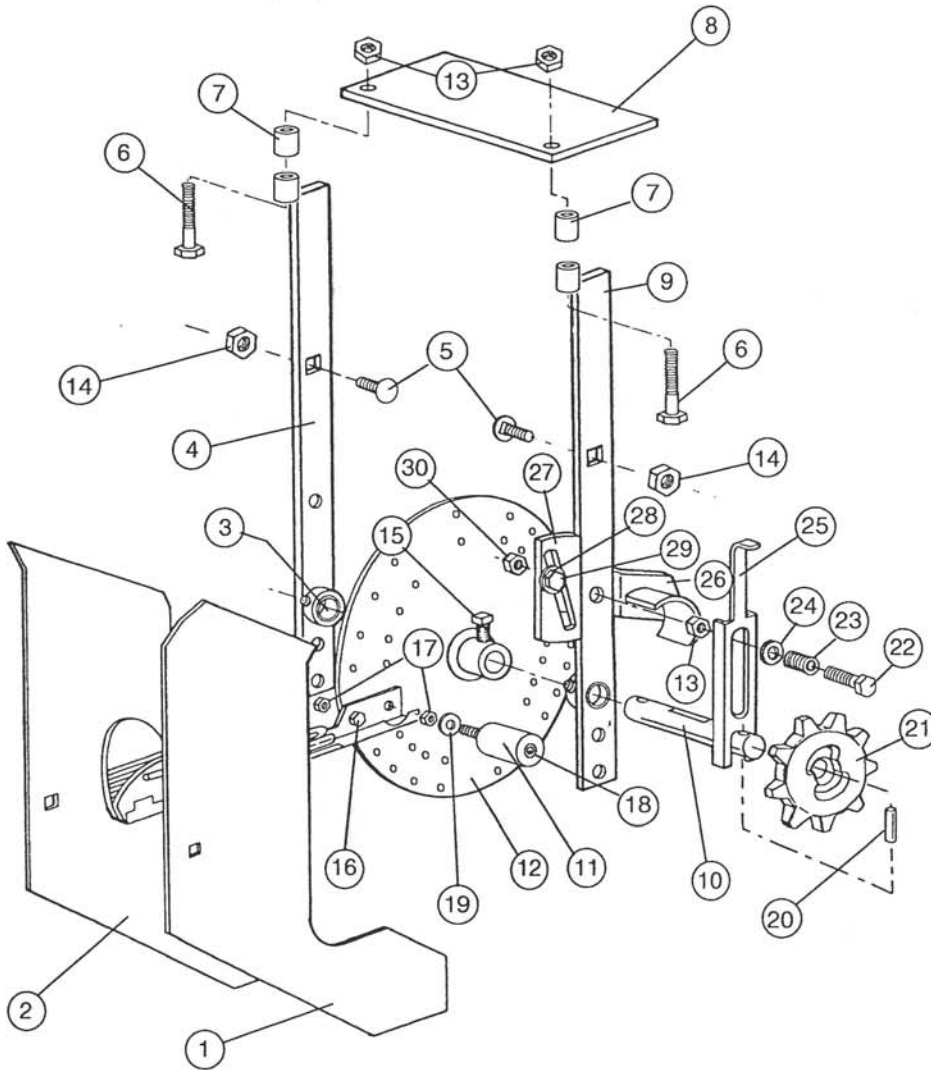

		Plant Spacing					
		Number of teeth on drive shaft spacing sprocket					
		6	7	8	9	10	11
4	12"	14"	16"	18"	20"	22"	
	31cm	36cm	41cm	46cm	56cm	56cm	
5	11"	12"	13"	14"	16"	18"	
	28cm	31cm	33cm	36cm	41cm	46cm	
6	10"	11"	12"	13.5"	15"	16.5"	
	25cm	28cm	31cm	34cm	38cm	42cm	
8	6"	7"	8"	9"	10"	11"	
	15cm	18cm	20cm	23cm	25cm	28cm	
10	5.5"	6"	6.5"	7"	8"	9"	
	14cm	15cm	17cm	18cm	20cm	23cm	
12	5"	5.5"	6"	7"	7.5"	8"	
	13cm	14cm	15cm	18cm	19cm	21cm	
16	3"	3.5"	4"	4.5"	5"	5.5"	
	8cm	9cm	10cm	11cm	13cm	14cm	
20			3"	3.5"	4"	4.5"	
			8cm	9cm	10cm	11cm	

Number of plant holders on disc.

Note: Reference guide only; actual plant spacing may vary. Adjust as needed.

Part # 10396  
Adaptable to  
different number  
of plant holders

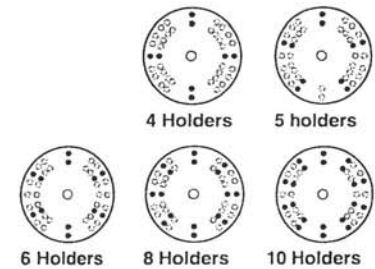

Ref#	Part #	Description
1	10003	Guide, left disc closing rod
2	10004	Guide, right disc closing rod
3	10002	Bushing, upright brace
4	10363	Brace, right upright (includes Ref # 3)
5	1380012	Bolt, 7/16 x 1-1/4 carriage
6	1280003	Bolt, 3/8 x 1-1/4 HHCS
	1280012	Bolt, 3/8 x 5 HHCS
	1280089	Bolt, 3/8 x 3 HHCS
7	10009	Tube, top plate spacer (1-1/2 long)
	10070	Tube, top plate spacer (3-1/2 long)
8	10010	Plate, upright top
9	10364	Brace, left upright (includes Ref No. 3)
10	10347	Shaft, lower conveyor sprocket drive
11	10051	Trip, water roller complete w/hardware. (includes Ref. # 11, 17, 18, 19)
12	10396	Disc, for 4-10 plant holder (includes Ref # 15)
	10397	Disc, for 12 plant holders (includes Ref # 15)
	10399	Disc, for 16 plant holders (includes Ref # 15)
	10398	Disc, for 20 plant holders (includes Ref # 15)
13	1480005	Nut, 3/8 hex
14	1480013	Nut, 7/16 hex
15	1780010	Screw, 3/8 x 3/4 sq hd set
16	1280021	Bolt, 1/4 x 5/8 HHCS

Ref#	Part #	Description
17	1480004	Nut, 1/4 hex
18	1780011	Screw, 1/4 x 1-1/2 soc set
19	1180002	Washer, 1/4 flat
20	10386	Pin, spacing sprocket drive
21	10380	Sprocket, 6 tooth spacing
	10381	Sprocket, 7 tooth spacing
	10382	Sprocket, 8 tooth spacing
	10383	Sprocket, 9 tooth spacing
	10384	Sprocket, 10 tooth spacing
	10385	Sprocket, 11 tooth spacing
22	1280084	Bolt, 3/8 x 2 tap
23	10081	Spring, spacer tension
24	1180004	Washer, 3/8 flat
25	10177	Spacer, sprocket channel
26	10176	Tightener, left side chain
27	10173	Bar, chain tightener adjustment
28	1180003	Washer, 5/16 flat
29	1280038	Bolt, 5/16 x 3/4 HHCS
30	1480012	Nut, 3/8 lock
	10041	Tightener, left complete (includes Ref # 13, 22 - 30)
	10042	Tightener, right complete (not shown)

# Chain Plant Holder Arrangement

For plant spacing 10-1/2" and more.

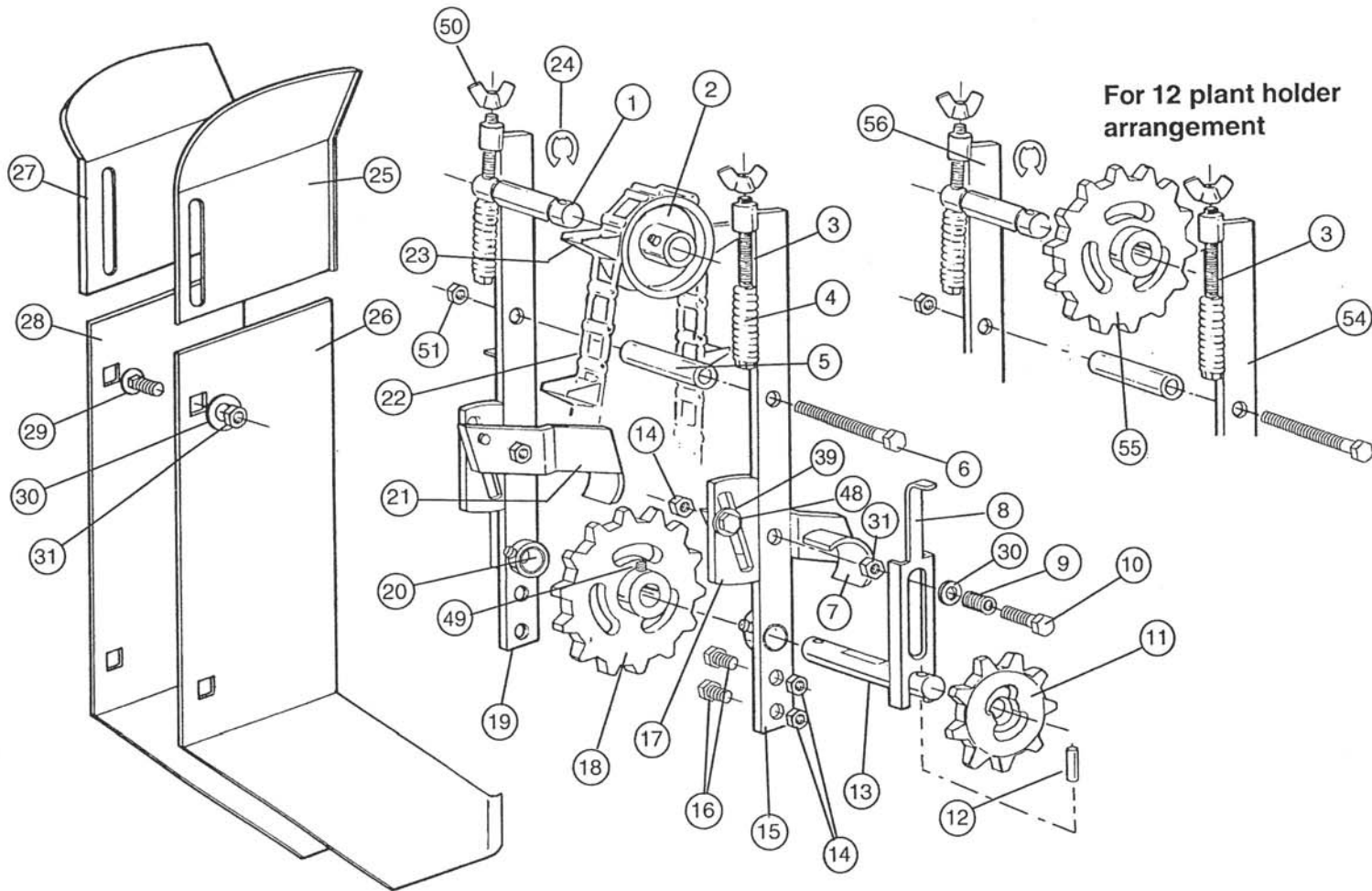

Ref #	Part #	Description
1	10050	Shaft, upper conveyor pulley
2	10051	Pulley, upper conveyor
	10379	Pulley, upper conveyor assy cpte. w/shaft (includes Ref # 1, 2 & 24)
3	1280012	Bolt, 3/8 x 5 tap (for 10377 & 10022 chain)
	1280035	Bolt, 3/8 x 6 tap (for 10388 & 10390 chain)
4	10376	Spring, conveyor pulley tension
5	10134	Spacer, upright tube
6	1280031	Bolt, 7/16 x 5-1/2 HHCS
7	10176	Tightener, left side chain
	10226	Tightener, left complete (includes Ref # 7-10, 14, 17, 30, 31, 39 & 48)
8	10177	Spacer, sprocket channel
9	10081	Spring, spacer tension
10	1280037	Bolt, 3/8 x 2-1/4 tap
11	10380	Sprocket, 6 tooth spacing
	10381	Sprocket, 7 tooth spacing
	10382	Sprocket, 8 tooth spacing
	10383	Sprocket, 9 tooth spacing
	10384	Sprocket, 10 tooth spacing
	10385	Sprocket, 11 tooth spacing
12	10386	Pin, spacing sprocket drive

Ref #	Part #	Description
13	10347	Shaft, lower conveyor sprocket drive
14	1480012	Nut, 3/8 lock
15	10364	Brace, left upright (includes Ref # 20)
16	1280003	Bolt, 3/8 x 1-1/4 HHCS
17	10173	Bar, chain tightener adjustment
18	10355	Sprocket, lower conveyor (includes Ref # 49)
19	10363	Brace, right upright (includes Ref # 20)
20	10002	Bushing, upright brace
21	10175	Tightener, right side chain
	10227	Tightener, right complete (includes Ref # 8-10, 14, 17, 21, 30, 31, 39 & 48)
22	10377	Chain, 8 holder attachment
	10388	Chain, 10 holder attachment
	10390	Chain, 6 holder attachment
	10022	Chain, 12 holder attachment
23	10374	Link, chain holder attachment
24	10053	Ring, upper pulley retaining
25	10077	Guide, left chain closing rod top
26	10078	Guide, left chain closing rod bottom
27	10076	Guide, right chain closing rod top

## Plant Spacing

### Chain Arrangement

	Number of teeth on drive shaft spacing sprocket					
	6	7	8	9	10	11
2	56" 142cm	64" 163cm	72" 183cm	80" 203cm	88" 224cm	96" 244cm
4	28" 71cm	32" 81cm	36" 91cm	40" 102cm	44" 112cm	48" 122cm
5	20" 51cm	24" 61cm	28" 71cm	32" 81cm	36" 91cm	40" 102cm
6	18" 46cm	20" 51cm	22" 56cm	24" 61cm	26" 66cm	28" 71cm
8	14" 36cm	16" 41cm	18" 46cm	20" 51cm	22" 56cm	24" 61cm
10	10.5" 27cm	12" 31cm	14" 36cm	16" 41cm	18" 46cm	20" 51cm
12	10.5" 27cm	12" 31cm	14" 36cm	16" 41cm	18" 46cm	20" 51cm

↑ Number of plant holders on chain

Note: Reference guide only; actual plant spacing may vary. Adjust as needed.

## Packing Wheels and Soil Scraper

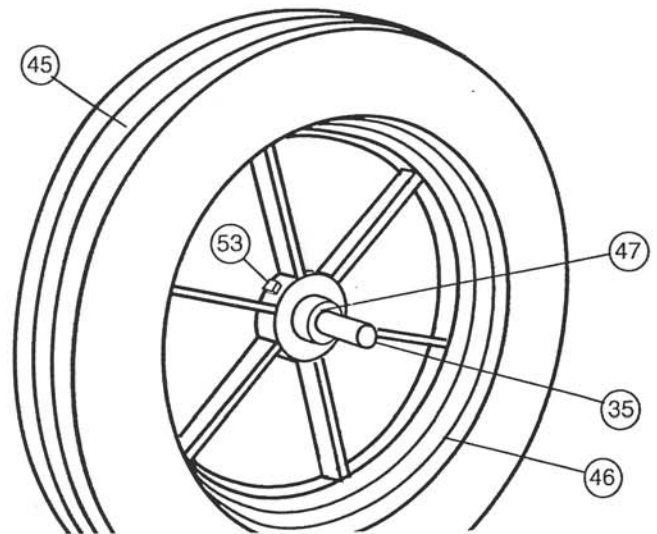
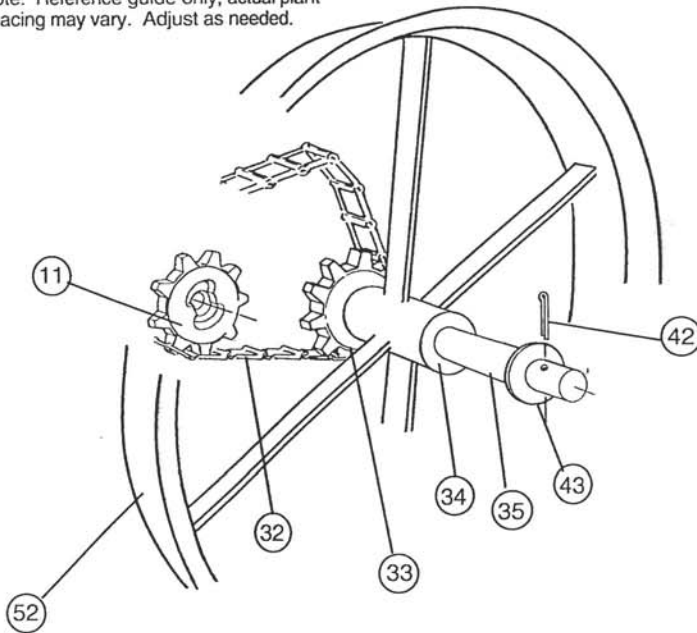
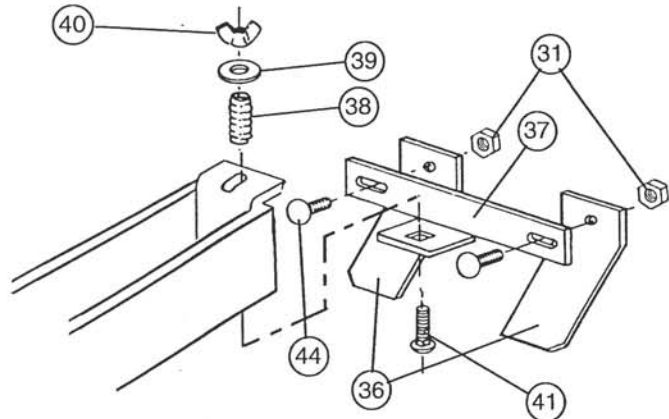

Ref#	Part #	Description
28	10079	Guide, right chain closing rod bottom
	10224	Guide, complete left chain closing rod (includes Ref # 25, 26, 29-31)
	10225	Guide, complete right chain closing rod (includes Ref # 27-31)
29	1380010	Bolt, 3/8 x 3/4 carriage
30	1180004	Washer, 3/8 flat
31	1480005	Nut, 3/8 hex
32	10365	Chain, pack wheel drive
33	10344	Sprocket, pack wheel drive
34	10138	Bushing, packing wheel
35	10357	Axle, packing wheel
36	10083	Blades, pack wheel scraper (pair)
37	10084	Crossbar, pack wheel scraper blade
38	10049	Spring, pack wheel adjustment
39	1180003	Washer, 5/16 flat
40	1480017	Nut, 5/16 wing
41	1380001	Bolt, 5/16 x 2-1/2 carriage
42	1880004	Cotter, 1/4 x 1-1/4

Ref#	Part #	Description
43	1680005	Bushing, 7/8
44	1380010	Bolt, 3/8 x 3/4 carriage
	10082	Complete scraper assembly, (includes Ref # 31, 36 - 41 & 44)
45	10228	Tire, rubber packing wheel
46	10229	Wheel, rubber pack
47	10230	Hub, rubber packing wheel (includes Ref # 33, 34 & 53)
	10231	Complete rubber pack wheel, (includes Ref # 45 - 47 & 53)
48	1280038	Bolt, 5/16 x 3/4 HHCS
49	1780009	Screw, 3/8 x 5/8 soc set
50	1480016	Nut, 3/8 wing
51	1480013	Nut, 7/16 hex
52	10127	Wheel, steel pack (includes Ref # 33 & 34)
53	1780008	Screw, 5/8 x 1 set
54	10039	Brace, left upright
55	10038	Sprocket, upper conveyor
56	10040	Brace, right upright

# Start-rite Water Valve

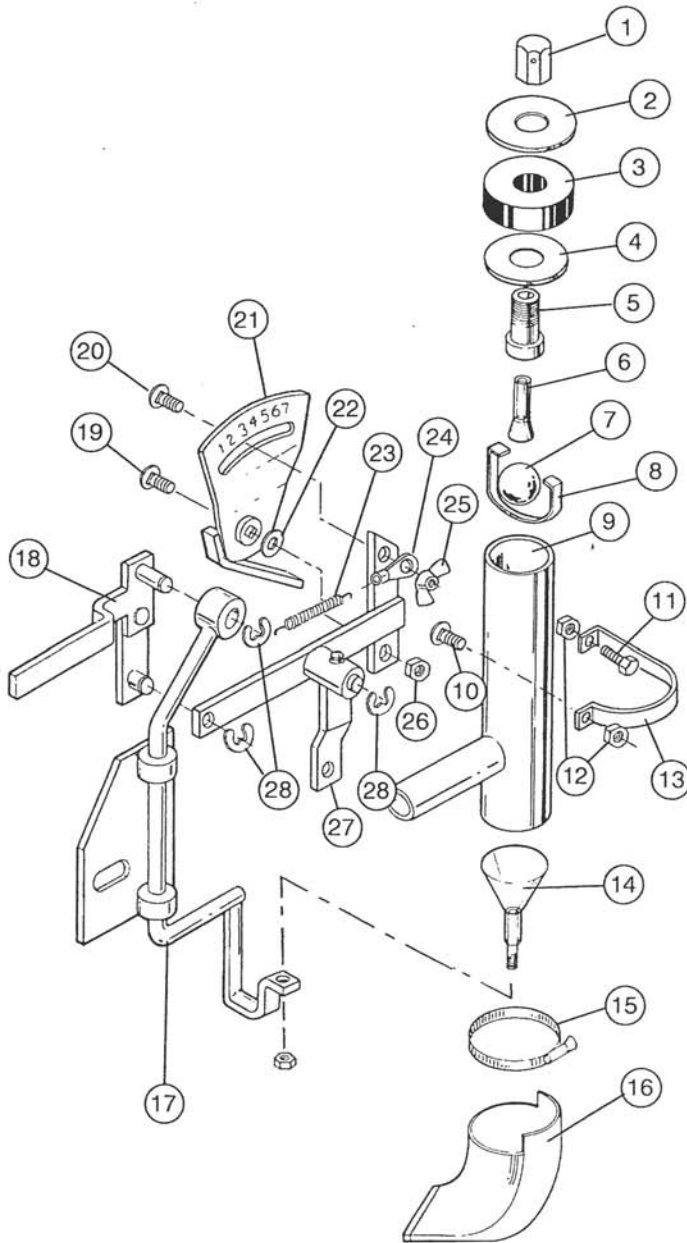

Ref #	Part #	Description
1	10151	Cap, air vent
2	10015	Washer, air vent cap
3	10011	Gasket, air vent rubber
4	1180008	Washer, 5/8 flat
5	10048 10093	Seat, air vent brass Assembly, air vent complete (includes Ref #: 3 - 5)
6	10092	Valve, brass air
7	10096	Float, air shutoff ball
8	10095	Support, brass ball
9	10012	Reservoir, for water
10	1380006	Bolt, 5/16 x 3 carriage
11	1280001	HHCS, 5/16 x 5/8
12	1480002	Nut, 5/16 hex
13	10063 10114	Clamp, water reservoir Reservoir, water reservoir complete (includes Ref # 1 - 13)
14	10094	Valve, lower rubber (includes locking nut)
15	10087	Clamp, water spout
16	10086	Outlet spout, water reservoir
17	10153	Rod, water trip control
18	10155	Control, manual water shutoff
19	1380011	Bolt, 5/16 x 5/8 carriage flat top
20	1380002	Bolt, 1/4 x 3/4 carriage
21	10147	Panel, water trip indicator
22	1080004	Washer, 3/8 flat
23	10152	Spring, water trip
24	10014	Anchor, water trip spring
25	1480018	Nut, 1/4 wing
26	1480003	Nut, 5/16 hex lock
27	10148	Assembly, water trip rocker
28	10052	Ring, water trip retaining
	10150	Complete assembly, water trip (includes Ref #: 17 - 28)
	10115	Complete assembly, water valve (includes Ref #: 1 - 28)



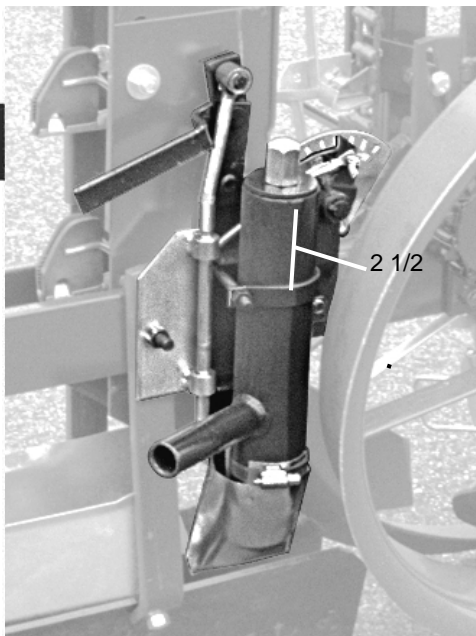

### Operation of water valve

The valve is designed to give an ample supply of water for most plant spacings. Should more water be desired, merely move the indicator to a higher number. Moving the indicator to a lower number will decrease the amount of water used. A setting of '1' will shut the valve off. The manual shutoff lever will shutoff the flow of water when the unit is stopped in a position where the water trip is engaged.

### Removal of parts

The valve is designed so all parts can be removed without taking it off the unit frame. The upper air valve (10092) and ball float (10096) can be replaced by removing the valve top. The valve top can be removed by turning the air vent cap (10151) counterclockwise until loose. Do not remove the cap from the brass vent seat (10048). When the vent cap is loose, the entire upper mechanism can be lifted off.

To remove the lower valve (10094), you must first remove the water reservoir spout (10086). Loosen the lock nut on the bottom of the valve and remove the water trip control rod. The valve can then be removed through the top of the reservoir. When reinstalling the lower valve, it is important that the plastic sleeve is in place and the lock nut tightened only enough to prevent it from coming off. If the lock nut is too tight, the lower valve will not seat properly and the valve will leak water.

### Maintenance

Grease the water trip rocker assembly before each use. All water trip linkage should move easily. Make sure all hose clamps are tight to prevent leakage.

After planting, remove the top of the valve and flush with water to clean. This is especially true when using fertilizer or chemicals in your water.

## Plant Holders

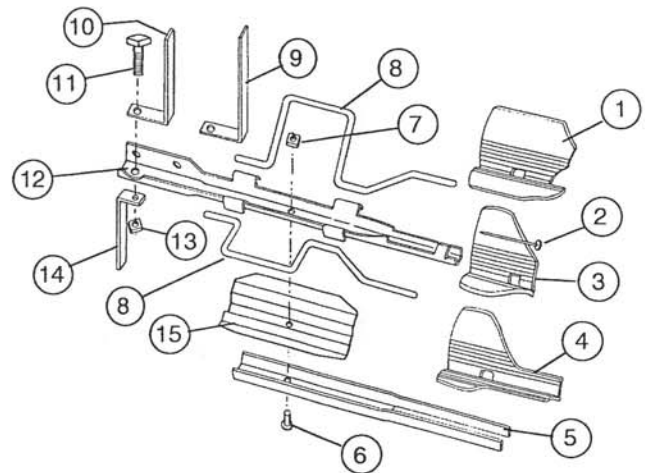

Ref #	Part #	Description
1	10020	Gripper, strawberry
2	10056	Nail, rubber gripper holding
3	10055	Gripper, standard rubber
4	10021	Gripper, small cell plants
5	10023	Fork, plant holder extension
6	1780003	Screw, 10-24 mach slot
7	1480008	Nut, 10-24 sq hd
8	10057	Rod, rubber gripper closing (pair)
9	10027	Spacer, plant holder (for 8 holder chain)
10	10026	Spacer, plant holder (for 10 & 12 holder chain)
11	1280038	Bolt, 5/16 x 3/4 sq hd
12	10058	Frame, plant holder
13	1480002	Nut, 5/16 hex
14	10025	Spacer, plant holder (for 6 holder chain)
15	10059	Cap, plant holder frame
	10007	Guide, bulb holder front (for chain units)(not shwn)
	10008	Guide, bulb holder front (for disc units)(not shwn)
	10037	Rod, rubber gripper closing (for 10020 gripper) (pair, not shown).

#### Part # 10054 Plant Holder

Standard holder, for most bare rooted seedlings such as tomatoes, peppers, cabbage, tobacco and all plants with a holdable top foliage and a normal root section.

#### Part # 10031 Plant Holder

For use with small cell tray or potted plants with a root section up to 1" dia. Rubber tail extension supports the root.

#### Part # 10030 Plant Holder

Designed for strawberries and other plants with large root section but small crown or top foliage.

#### Part # 10032 Plant Holder

For use with larger potted plants with a root section up to 1-1/2" dia. Rubber gripper holds top of plant; dual fork supports the root.

#### Part # 10033 Bulb Holder

For planting bulbs, potatoes, etc. up to 1-1/2" diameter. Must be used with a front guide attachment (not shown).

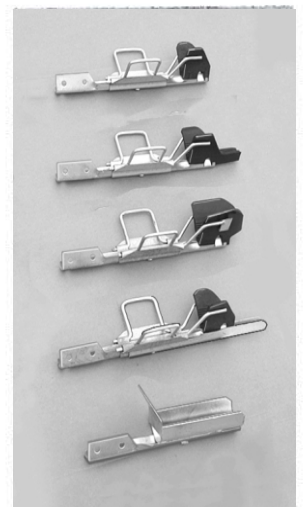

# Plant Boxes and Seat Bar

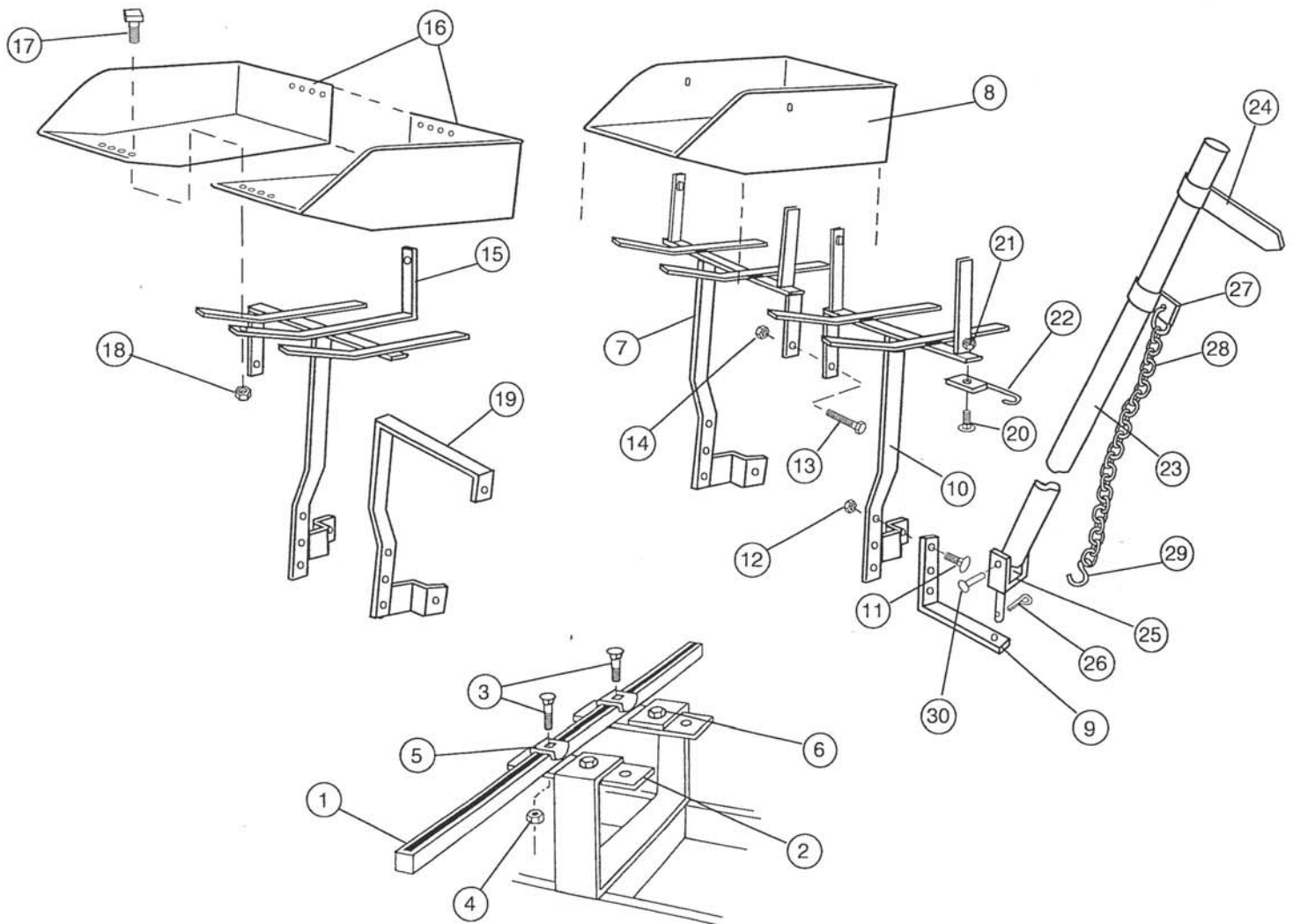

Ref #	Part #	Description
1	10213	Bar, seat mounting
2	10214	Bracket, seat bar adjustment
3	1380014	Bolt, 1/2 x 2 carriage
4	1480010	Nut, 1/2 hex
5	13021	Washer, seat bracket bent
6	1280013	HHCS, 1/2 X 1-1/4
7	10215	Stand, plant box right side
8	10219	Box, standard plant holder
9	10223	Footrest, unit
10	10216	Stand, plant box left side
11	1380005	Bolt, 3/8 x 1-1/4 carriage
12	1480005	Nut, 3/8 hex
13	1280031	Bolt, 7/16 x 5-1/2 HHCS
14	1480013	Nut, 7/16 hex
15	10221	Stand, adjustable center plant box

Ref #	Part #	Description
16	10220	Box, adjustable plant holder
17	1280038	Bolt, 5/16 x 3/4 sq hd
18	1480002	Nut, 5/16 hex
19	10043	Bracket, support
20	13800P3	Bolt, 3/8 x 1 carriage
21	1480005	Nut, 3/8 hex
22	13102	Marker pipe, hook bracket
23	13103	Marker pipe, with yoke
24	13104	Marker blade
25	13105	Marker pipe, swivel yoke
26	188000Y	Cotter key, 1/4 x 1-1/4
27	13106	Chain clamp
28	13107	Pipe chain, with "S" hook
29	1980025	"S" hook, for chain
30	0001580008	Rivet, for #25 yoke (through pipe)

# Trouble Shooting Chart

Problem	Cause	Remedy
No water by plants.	Obstruction in barrel or line.	Remove trash or dirt that may have lodged in water barrel, supply hose or valve.
	Valve not operating.	Remove soil wedged between rod and closing guide preventing movement of control rod. Check the lower end of control rod for clearance along outside of valve reservoir. Rod should not rub side of reservoir during upward stroke. Check lower rubber valve (10094). Some chemicals could cause this valve to swell in size, preventing water to flow and/or restrict free movement of this valve. Replace with new valve.
Water leakage.	Broken ball float	Replace float (10096), support (10095) and air vent (10093).
	Lower valve not seated.	The lower rubber valve is not seated in the brass orifice. Rubber valve must not be tight to end of control rod. Loosen nut on rubber valve until it is flush with the stem. There should be 1/8" clearance between the top of the rod end and bottom of the plastic tube on stem of rubber valve. This will allow the valve to seat itself when the control rod is in the down closed position.
Broken plants.	Plants not in line.	Check furrow opener braces for tightness. Sight opener to determine if it lines up in center of opening between packing wheels.
	Wheels out of line, riding on plants.	Turn wheel by hand to see if it is bent. Replace bent packing wheels.
	Plant holders too rigid at release point.	Check conveyor chain (10377). Loosen upright bolts to allow chain a little play. Adjust bolts to center the chain in the pulley (10051).
Plants not packed tightly in soil.	Furrow too wide.	Remove caked soil from side of furrow opener. Remove trash from front of furrow opener.
	Transplanter unit riding on furrow opener.	Check soil to see if it is tilled to proper furrow depth. This can easily be done by inserting hand down into furrow just planted. If hand does not go in beyond depth of opener, machine is riding on opener thereby not allowing wheel weight to properly pack soil around plants. Rework soil deeper. If planting small plants, raise furrow opener so weight of machine will ride on wheels instead of furrow opener.
	Unit not floating.	Check drawbar for clearance below unit frame so unit can float over soil contour.
Plants leaning.	Soil getting in opener before plant.	Move furrow opener closer to packing wheels. Lower furrow opener to avoid soil flowing under.
	Both sides of plant holder not opening at same time.	Check to see that both guides are parallel and straight across from each other on the bottom where the plant is released. If the closing rods (10057) do not open at the same time, one side may hold plant momentarily, causing it to lean or be loose in the ground.
	Soil too loose.	If soil is rototilled or very loose, the packing wheels may not get enough traction to propel the transplanter. When the packing wheels slip, the plant holders do not move and will drag the plants in the direction the machine is going. It is recommended to work ground deep but leave some "body" to soil so packing wheels can get traction. If soil is too loose, firm up soil with packer. For loose soil conditions replace steel packing wheels with rubber packing wheels for more traction.

# Limited Warranty

HOLLAND TRANSPLANTERS COMPANY'S (herein referred to as the Company) responsibility will be limited to the substitution of the acknowledged defective merchandise to the same place of delivery as the previous one was supplied.

1. The Company warrants its machines and related accessories to be free from defects in material and workmanship, for a period of six (6) months from the date of invoice to the first registered owner with the exclusion of shear pins, oil, grease, tires, hydraulic hoses and cylinders. Labor will be reimbursed at \$15.00 per hour based on the Company's time schedule.

2. Rental: If the machine is used for rental purposes, the warranty period is limited to thirty (30) days from date of invoice and does not cover any labor charges incurred.

3. Registration: In order to qualify for coverage on this limited warranty, the product and name of the original purchaser must be registered with the Company by mailing a completed Warranty Registration card along with a copy of the dealer's invoice to the Company within thirty (30) days after the date of delivery.

4. Service: Warranty service must be performed by a dealer authorized by the Company. If the warranty request is approved, the owner shall pay only for labor beyond the rate allowed, for overtime labor, and for any mileage charge for transporting the equipment to and from the dealer's shop. Time required for replacement of oil, grease and to remove excessive dirt from the machine is not subject to reimbursement by the company. The owner is required to clean the machine before presenting it to the dealer for service work. The machine must be delivered within thirty (30) days after failure to be eligible for warranty consideration.

5. Accidents and Normal Maintenance: This warranty covers defective material and workmanship. It does not cover depreciation or damage caused by normal wear, accidents, improper

maintenance, improper protection or improper use. The cost of normal maintenance and related labor will be the owners.

6. Warranty termination: All obligations of the Company under this warranty shall be terminated if; proper service and operation as outlined in the Owner's Manual are not followed, the machine is modified or altered in any way not approved by the Company, the Company does not receive a copy of the invoice and registration card within thirty (30) days from delivery date, the Company has not been paid in full for the machine.

7. Implied warranty: Neither the Company nor any company affiliated with the Company makes any warranties, expressed or implied, as to the quality, performance or application of its products other than those set forth herein.

8. Remedies exclusive: The only remedies the purchaser has in connection with the breach, or performance of any warranty on the Company's machine are those set forth herein. In no event will the dealer, the Company, or any company affiliated with the Company be liable for: a) Injuries or damages of any kind, direct, consequential or contingent to person or property. b) Any expenses incurred by the owner to repair, replace or rework any allegedly defective item. c) Any loss, cost or damages (including loss of profits; loss of crops; loss because of delay in field operations; any expense or loss incurred for labor, supplies, rental; liabilities of owner to third parties; and all other damages, losses, liabilities for any other reasons) whether direct or indirect, and whether or not resulting from the Company as a result of the failure of the equipment delivered.

9. The Company's liability shall be limited to the replacement or refund of the purchase price of the product. The limited warranty stated herein gives the owner specific rights along with other rights which may vary from State to State. All implied warranties are expressly disclaimed subsequent to the terms of this warranty.



## HOLLAND TRANSPLANTER CO.

510 E. 16th St., P.O. Box 1527 / Holland, MI 49423-1527 U.S.A. / 616-392-3579 / 800-275-4482  
website: [www.transplanter.com](http://www.transplanter.com) / e-mail: [sales@transplanter.com](mailto:sales@transplanter.com) / fax 616-392-7996

Leaders in the field since 1927

Literature No. 95048. Printed in USA, 02/00