

**FALC**

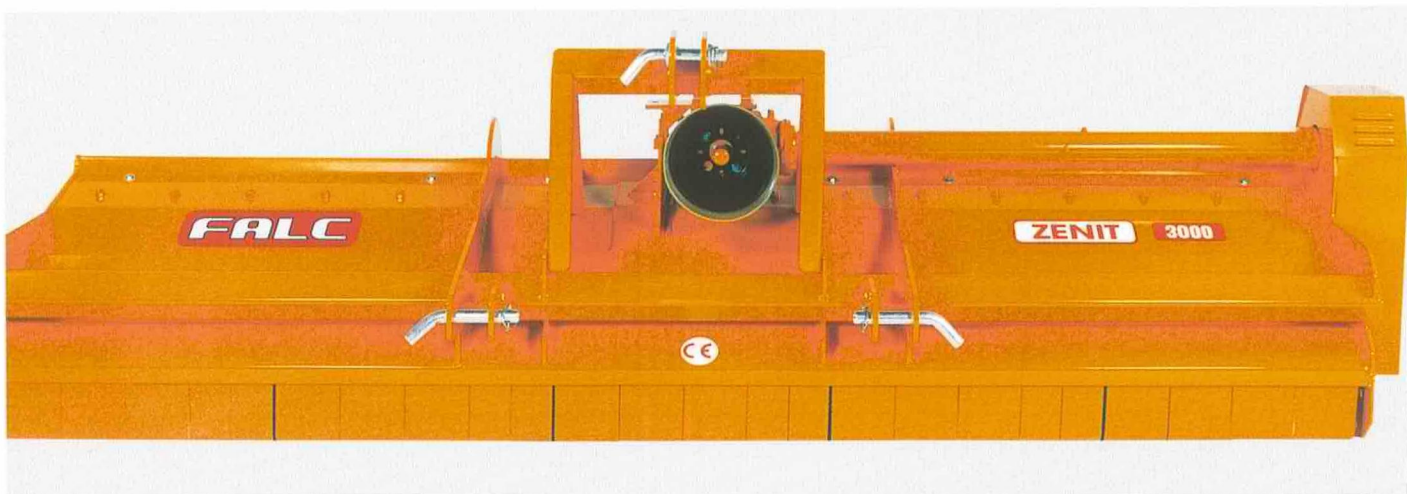

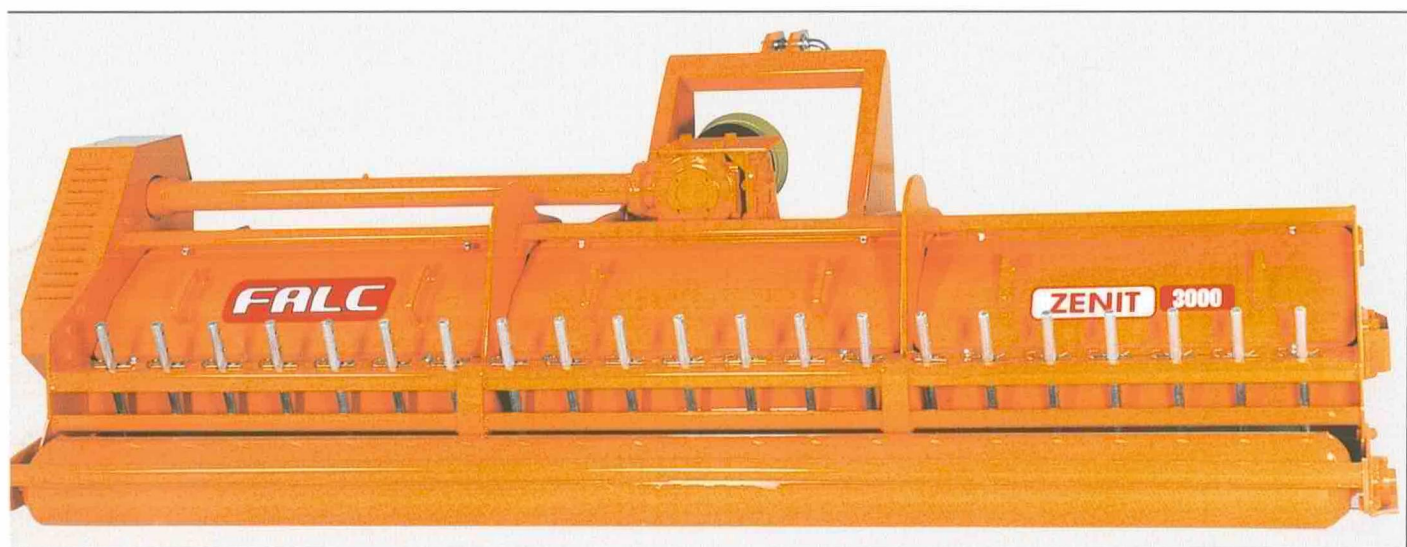

<b>I</b> Attacco fisso centrale.	<b>D</b> Zentraler-Dreipunktanbau.
<b>F</b> Attelage fixe central.	<b>E</b> Enganche fijo central.
<b>GB</b> Central fix linkage.	<b>P</b> Engate fixo central.



ZENIT FISSO ZENIT SPOSTABILE								ZENIT FISSO		ZENIT SPOSTABILE		<b>I</b> G/M del rotore <b>F</b> T/M du rotor <b>GB</b> Rotor's RPM <b>D</b> Rotor U/M <b>E</b> R/M del rotor <b>P</b> G/M do rotor			
	mm.		inches					N.	PTO	HP	KG		LBS	KG	LBS
	A	B	A	B											
1400	1405	1679	55,315	66,102	14	540 *	50 - 90	510	1124	-	-	2250			
1600	1585	1859	62,402	73,189	16	540 *	50 - 90	595	1312	660	1455	2250			
1800	1765	2039	69,488	80,276	18	540 *	50 - 90	630	1389	720	1587	2250			
2100	2125	2399	83,661	94,449	22	540 *	50 - 90	720	1587	800	1764	2250			
2300	2305	2549	90,748	100,354	24	540 *	60 - 90	800	1764	850	1874	2250			
2500	2485	2759	97,835	108,622	26	540 *	60 - 90	870	1918	910	2006	1822			
2700	2665	2939	104,921	115,709	28	540 *	60 - 90	950	2094	990	2183	1822			
3000	3025	3299	119,094	129,882	32	540 *	60 - 90	1020	2249	1090	2403	1822			

- I** TRINCIA SPECIALE CON SPOSTAMENTO IDRAULICO (cm 40) PER FILARI STRETTI
- F** BROYEUR SPECIAL AVEC DEPLACEMENT HYDRAULIQUE (cm. 40) POUR RANGEES ETROITES
- GB** SPECIAL SHREDDER WITH HYDRAULIC OFFSET (cm. 40 - Inches 15,748) FOR NARROW ROWS
- D** SONDERHÄCKSLER MIT HYDRAULISCHEN VERSCHIEBUNG (cm. 40) FÜR ENGE LAGE
- E** DESBROZADORA ESPECIAL CON CAMBIO HIDRAULICO (cm.40) PARA PERFILES ESTRECHOS
- P** TRITURADOR ESPECIAL COM DESLOCAMENTO HIDRAULICO (cm. 40) PARA FLAÇÕES ESTREITAS



BETA									
	A mm.	B mm.	A inches	B inches			Kg.	LBS.	
1200	1225	1409	48,228	55,472	540	50 - 90	540	1190	12
1400	1405	1589	55,315	62,559	540	50 - 90	610	1345	14

FALC - Via Proventa, 41 - 48018 FAENZA (ITALIA) - e-mail: info@falc.eu - www.falc.eu

Numero nazionale:  
Tel. 0546 29050  
Fax 0546 663986

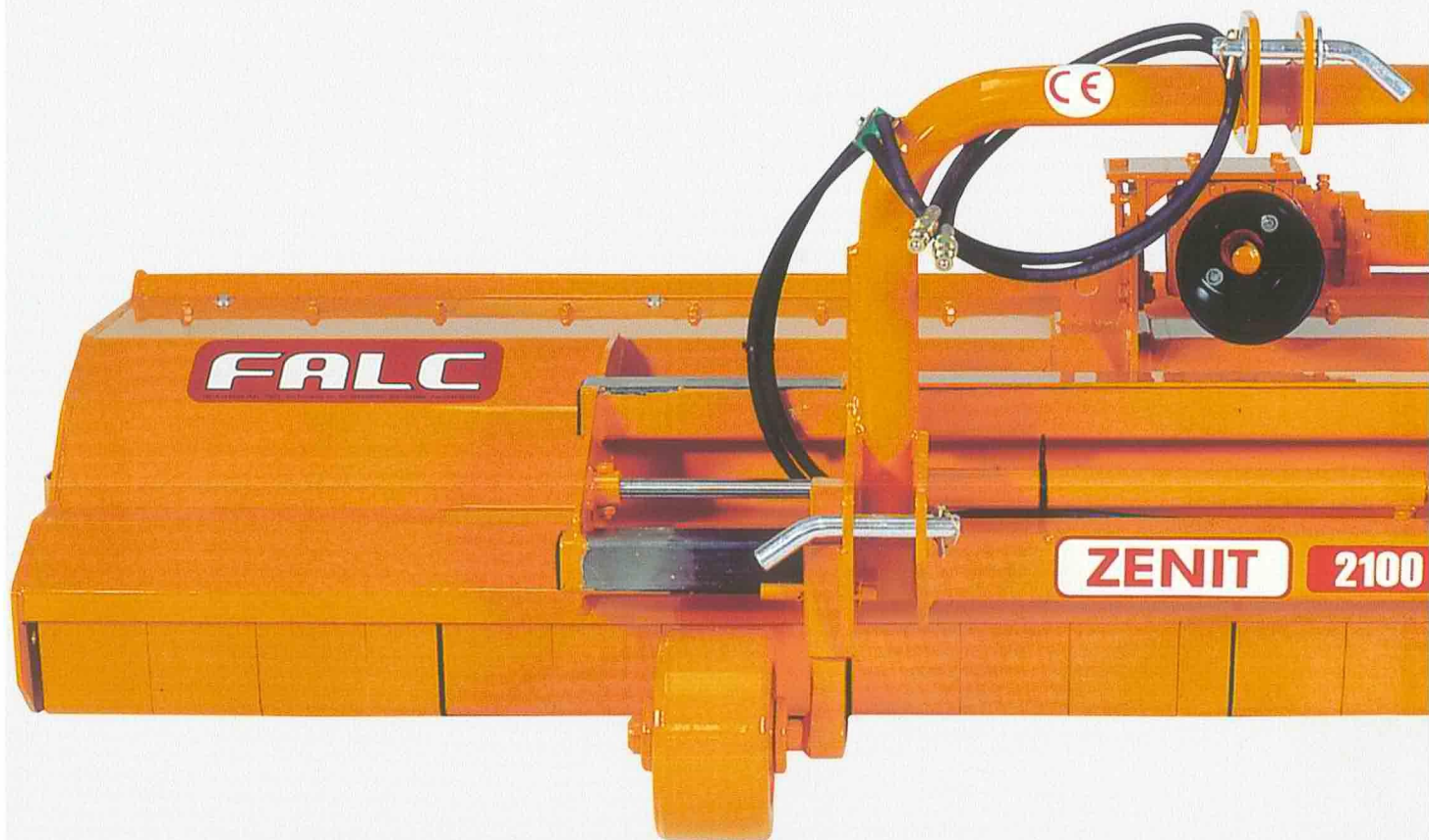

**ZENIT**  
**SPOSTABILE**

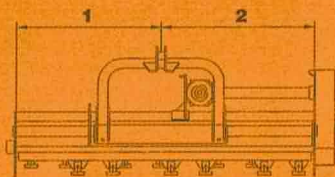

**ZENIT**  
**SPOSTABILE**

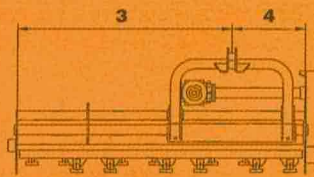

SERIE	1 + 2 =			1 + 2 =			3 + 4 =			3 + 4 =		
	mm.	mm.	mm.	inches	inches	inches	mm.	mm.	mm.	inches	inches	inches
1600	733	852	1585	28,859	33,544	62,402	1333	252	1585	52,481	9,922	62,402
1800	913	852	1765	35,945	33,544	69,489	1513	252	1765	59,567	9,922	69,489
2100	1273	852	2125	50,119	33,544	83,662	1873	252	2125	73,741	9,922	83,662
2300	1258	1047	2305	49,528	41,221	90,749	1858	447	2305	73,150	17,599	90,749
2500	1298	1187	2485	51,103	46,733	97,835	1898	587	2485	74,725	23,111	97,835
2700	1368	1297	2665	53,859	51,063	104,922	1968	697	2665	77,481	27,441	104,922
3000	1588	1437	3025	62,520	56,575	119,095	2188	837	3025	86,142	32,953	119,095

### ZENIT Stone Line

**I** Esiste la versione per terreni sassosi:  
I perni porta martelli standard ①, sono sostituiti dai perni ②.

**D** Es gibt die Version für Steinboden:  
die Standard Bolzen für Hämmer ① sind mit die Sonderbolzen ②



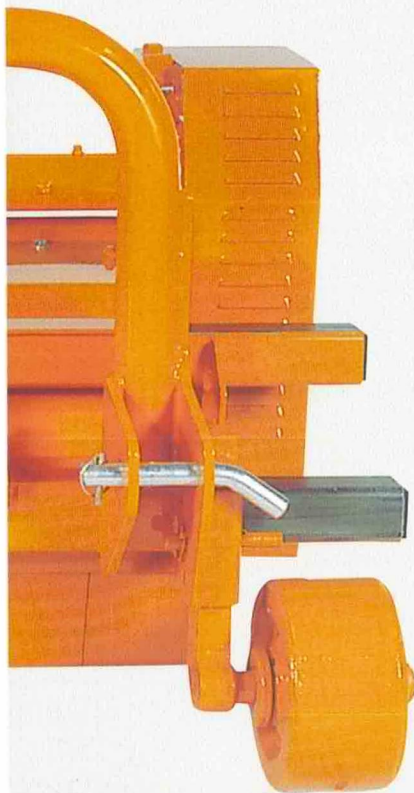

- I** Spostamento idraulico cm 60
- F** Déplacement hydraulique cm 60
- GB** Hydraulic offset cm 60 (inches 23,622)
- D** Hydraulischer Verschiebung cm 60
- E** Desplazamiento hidráulico cm 60
- P** Deslocamento hidráulico cm 60

- I** \* A RICHIESTA : P.T.O. 1000 G/M.
- F** \* SUR DEMANDE : P.D.F. 1000 T/M.
- GB** \* ON REQUEST : P.T.O. 1000 RPM.
- D** \* AUF WUNSCH : P.T.O. 1000 U/M.
- E** \* A PEDIDO : T.D.F. 1000 V/M.
- P** \* A PEDIDO : T.D.F. 1000 G.M.

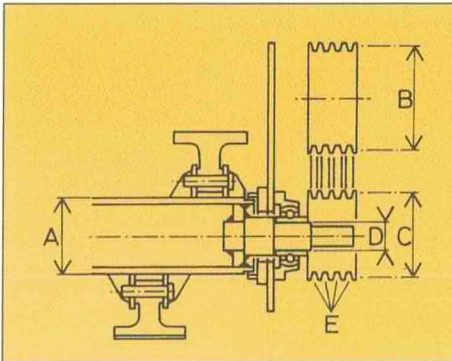

- A Ø mm. 193,7 inches 7,626
- B Ø mm. 250 inches 9,843  
(1400-1600-1800-2100-2300)
- B Ø mm. 225 inches 8,858  
(2500-2700-3000)
- C Ø mm. 180 inches 7,087  
(1400-1600-1800-2100-2300)
- C Ø mm. 200 inches 7,874  
(2500-2700-3000)
- D Ø mm. 50 inches 1,969
- E N° 3 MOD. 1400  
N° 4 MOD. 1600-1800-2100-2300  
N° 5 MOD. 2500-2700-3000

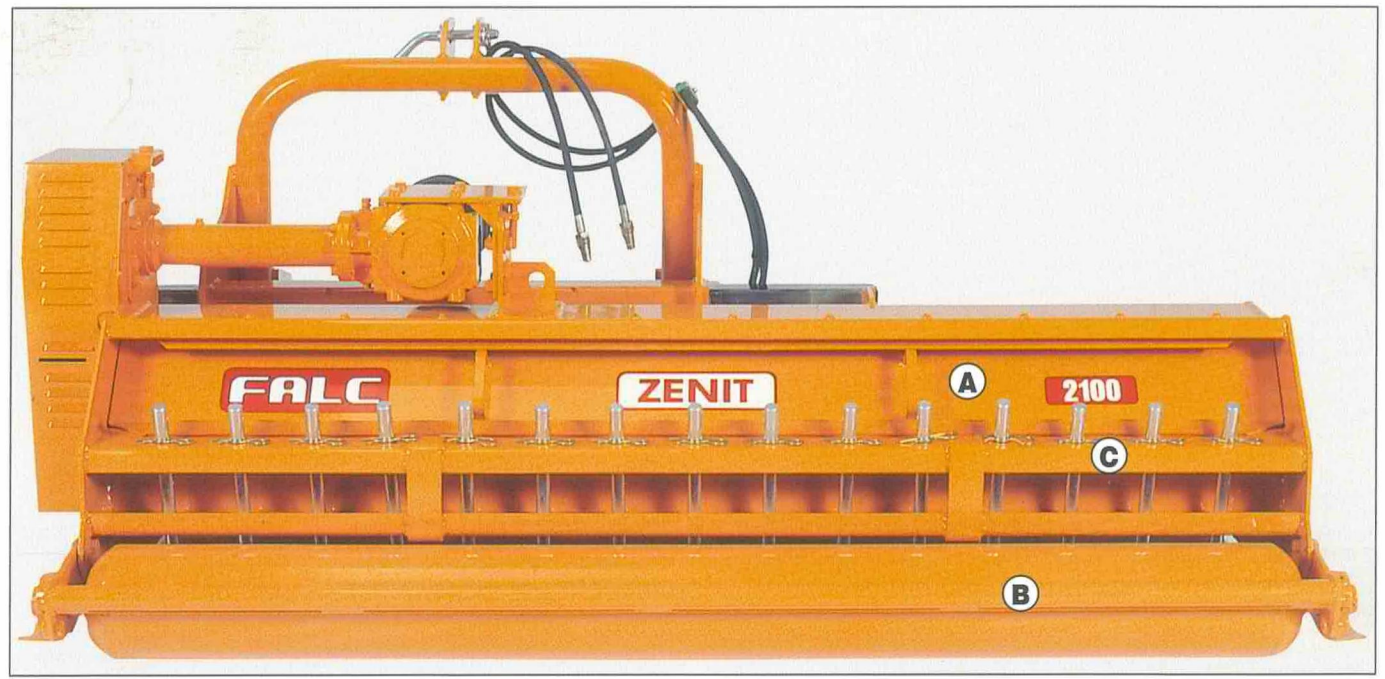
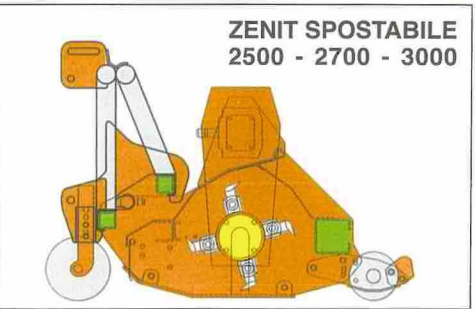
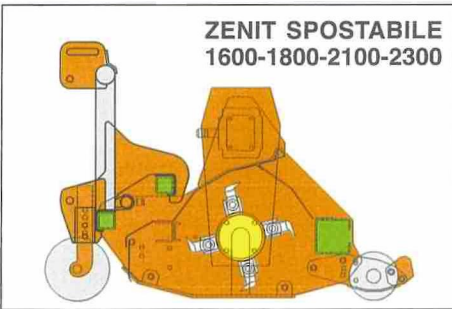

**I** Di serie: **A** cofano apribile per manutenzione. **B** rullo **D** Serienmäßige Ausrüstung **A** zu öffnende Schließhaube für

- I** Trincia versatile ideale per Aziende Agricole con colture diversificate.
- F** Broyeur universel, idéal pour exploitations agricoles à cultures diversifiées.
- GB** Versatile shredder, ideal for different crops farms.
- D** Vielseitiger Häcksler, ideal für den Einsatzbereichen der Landwirtschaft.
- E** Desbrozadora polivalente ideal para haciendas agrícolas con cultivos diversificados.
- P** Triturador versátil perfeito para fazendas agrícolas com diversificação de culturas.

- I** A richiesta:
  - Ruote anteriori in ferro
  - Ruote sterzanti posteriori in gomma
  - Lamiera d'usura
  - Secondo controcoltello

- F** Sur demande:
  - Roues antérieures en fer
  - Roues postérieures braquantes en gomme
  - Tôle d'usure
  - Deuxième contrecofteau

- GB** On request:
  - Front iron wheels
  - Rear steering wheels (tyres)
  - Wear and tear sheet
  - Second counterblade

- D** Sonderausstattung:
  - Metallräder vorne
  - Steuernde Räder hinten
  - Verschleißblech
  - 2 Reihe Gegenmesser

- E** A pedido:
  - Ruedas anteriores en hierro
  - Ruedas posteriores de goma
  - Chapa de desgste
  - Segunda contracuchilla

- P** Com pedido:
  - Rodas anteriores de ferro
  - Rodas de trias de borracha
  - Chapa de desgaste
  - Segunda contrafaca

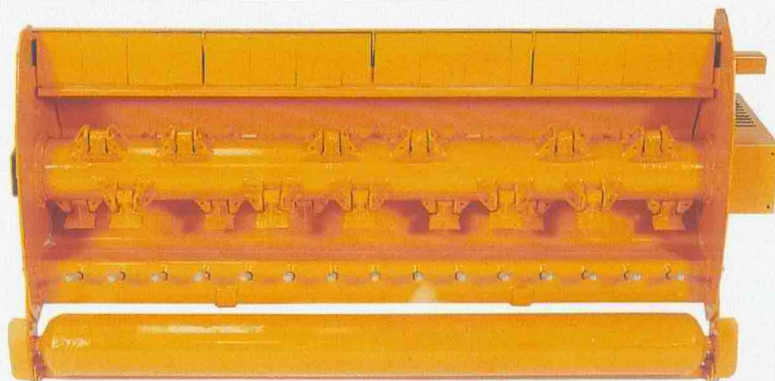

- I** Per la trinciatura delle erbe, dei residui delle potature, dei residui vegetali in genere come mais, sorgo, girasole, soia, ecc.
- F** Pour le broyage des herbes, sarments, résidus végétaux en general comme maïs, sorgho, soja, tournesol, etc.
- GB** For the chopping of grass, prunings, vegetal residuals in general such as maize, sorghum, sunflowers, soja, etc.
- D** Für das Häckseln von Gras/Weideflächen, Pflanzenresten wie Mais/Hirse/Soja oder Sonnenblumen, Schnittpolz aus Obst- oder Weinkulturen.
- E** Para trinchar hierbas, residuos de poda, restos vegetales en general como maíz, sorgo, girasol, soja, etc.
- P** Para triturar ervas, residuos de podas, restos vegetais em geral como milho, sorgo, girassol, soja, etc.

