

SERIE	mm.	inches	mm.	inches	kg.	LBS	N.	P.T.O.	HP

**PANDA** **20-35 HP** **540**

1000	997	39,26	220	8,66	225	496,03	4	540	20-35
1300	1307	51,46	220	8,66	310	683,42	6	540	20-35
1500	1477	58,15	220	8,66	330	727,51	6	540	20-35

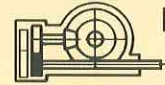

M 5,75

540	○ 16	○ 15	○ 14	○ 13
	● 13	● 14	● 15	● 16
	114	130	150	172

**MINI TORO** **30-60 HP** **540**

SERIE	mm.	inches	mm.	inches	kg.	LBS	N.	P.T.O.	HP
1000	1004	39,53	250	9,85	380	837,74	4	540	30-60
1200	1165	45,87	250	9,85	395	870,81	4	540	30-60
1300	1412	55,60	250	9,85	480	1058,20	6	540	40-60
1500	1508	59,38	250	9,85	500	1102,29	6	540	40-60
1700	1684	66,30	250	9,85	520	1146,38	6	540	45-60
1800	1818	71,58	250	9,85	590	1300,71	8	540	50-60
2000	1952	76,86	250	9,85	610	1344,80	8	540	50-60

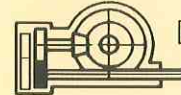

M 6,25

540	○ 16	○ 15	○ 14	○ 13
	● 13	● 14	● 15	● 16
	120	140	160	180

**TORO** **40-90 HP** **540**

SERIE	mm.	inches	mm.	inches	kg.	LBS	N.	P.T.O.	HP
1500	1504	59,22	350	13,78	675	1488,10	6	540	40-90
1700	1680	66,15	350	13,78	710	1565,26	6	540	45-90
1800	1814	71,42	350	13,78	830	1829,80	8	540	60-90
2000	1958	77,09	350	13,78	880	1940,04	8	540	60-90
2200	2210	87,01	350	13,78	1080	2380,95	10	540	70-90
2500	2480	97,64	350	13,78	1120	2469,14	10	540	70-90

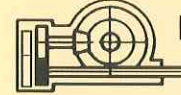

M 7,5

540	○ 16	○ 15	○ 14
	● 14	● 15	● 16
	120	140	160

**LEOPARD** **80-180 HP** **1000**

SERIE	mm.	inches	mm.	inches	kg.	LBS	N.	P.T.O.	HP
2500	2500	98,42	350	13,78	1400	3086,42	10	540	80-120
3200	3150	124,02	350	13,78	1720	3791,89	12	1000	80-120
4200	4130	162,60	350	13,78	2610	5753,97	16	1000	80-180



M 11

1000	540				
3200	MOD. 2500				
○ 24	○ 23	○ 20	○ 19	○ 18	○ 17
● 13	● 14	● 17	● 18	● 19	● 20
165	187	140	158	175	196

nota: nella 4200 è montata la scatola mod. 11,6 \*

**BUFALO** **100-180 HP** **1000**

SERIE	mm.	inches	mm.	inches	kg.	LBS	N.	P.T.O.	HP
3100	3120	122,84	400	15,75	2300	5070,55	10	1000	100-180

\*

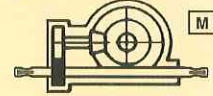

M 11,6

1000	○ 25	○ 23
	● 12	● 14
	131	166

**DRAGO** **100-240 HP** **1000**

SERIE	mm.	inches	mm.	inches	kg.	LBS	N.	P.T.O.	HP
3100	3120	122,84	500	19,69	2640	5820,11	10	1000	100-240

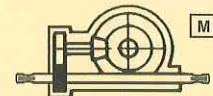

M 12

1000	○ 34	○ 31
------	------	------

**TORO**

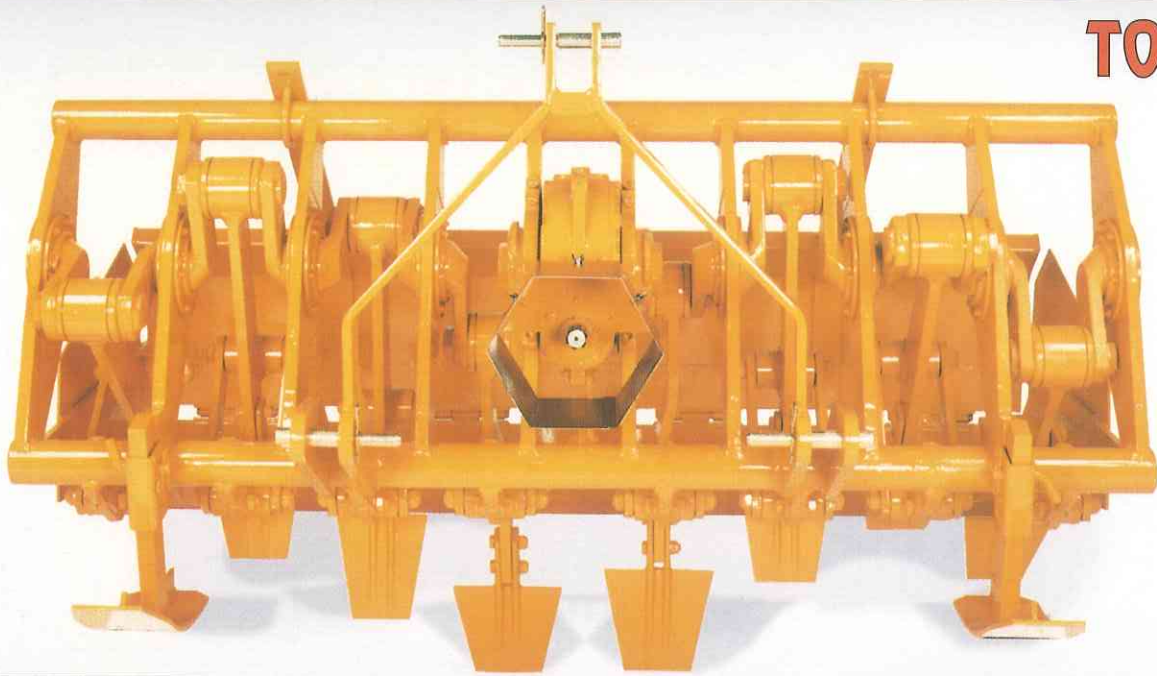

**MINI TORO**

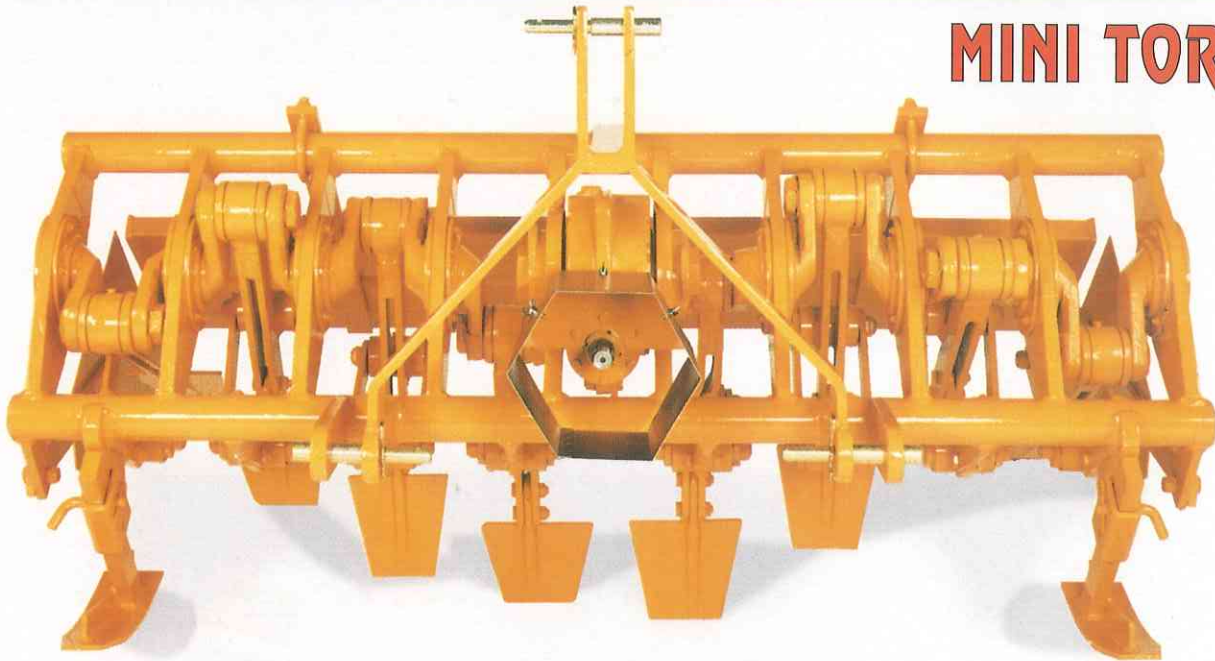

**PANDA**

