



**Mod. NEXT SP.
Mod. NEXT AVANT**

**TRINCIA - BROYEUR - SHREDDER
HÄCKSLER - TRITURADORA - ИЗМЕЛЬЧИТЕЛЬ**



Trincia con spostamento idraulico per erba, residui di potature medio-leggere e residui vegetali.
Abbinabile anteriormente e posteriormente a trattori da 40 a 60 HP

Broyeur déportable hydraulique pour herbes, sarments légers-moyennes et résidus végétaux.
Il peut être monté à l'avant ou à l'arrière des tracteurs de 40-60 CV

Shredder with hydraulic offset for grass, light-medium prunings and vegetal residues.
It can be fitted both in the front and back of 40-60 HP tractors

Häcksler mit hydraulischer Verschiebung für Gras, mittelleichte Baumschnitten und Pflanzenreste. Für Front- und Heckanbau an Traktoren von 40 bis 60 PS

Trituradora con desplazamiento hidráulico para hierba, residuos de poda medio-ligeros y restos vegetales. Acoplable anteriormente y posteriormente a tractores de 40 a 60 HP

Для измельчения травы, остатков срезанных веток средне-легких, растительных остатков
для тракторов от 40 до 60 л.с.





NEXT SP. NEXT AVANT										
	Kg.	LBS	A mm.	B mm.	A inches	B inches	N.	HP	PTO	N.
1350	390	860	1382	1555	54,41	61,22	18	40 - 60	540 (1000)	3
1500	415	914	1524	1697	60,00	66,81	20	40 - 60	540 (1000)	3
1800	458	1010	1808	1981	71,18	77,99	24	40 - 60	540 (1000)	3
2100	509	1123	2092	2265	82,36	89,17	28	40 - 60	540 (1000)	4

A



- Rullo posteriore
- Controcoltello
- Spostamento idraulico mm 400
- Perni filettati con dado (A)
- Lamiera d'usura (OPZIONE)



- Rouleau arrière
- Contre couteau
- Déportable hydraulique mm 400
- Axes filetés avec écrou (A)
- Tôle d'usure (OPTION)



- Rear roller
- Counter blade
- Hydraulic offset mm 400
- Axles with nut (A)
- Wear & tear sheet (OPTION)



- Hintere Walze
- Gegenmesser
- Hydraulische Verschiebung mm 400
- Gewindebolzen mit Mutter (A)
- Verschleißblech (OPTION)



- Rodillo posterior
- Contra cuchilla
- Desplazamiento hidráulico mm 400
- Pernos roscados con tuerca (A)
- Chapa de desgaste (OPCIONAL)



- Заднекатка
- Контрлезвие
- Гидравлическое смещение 400 мм
- Штыри с резьбой с гайкой (A)
- Листовой износ (ОПЦИЯ)

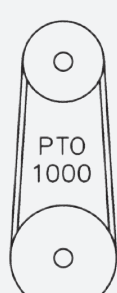
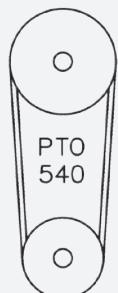

Invertendo la posizione delle pulegge si passa da PTO 540 a PTO 1000



Inversant la position des poulies on passe de PDF 540 à PDF 1000



Inverting the position of the pulleys you change from PTO 540 to PTO 1000



Um die Umdrehungen von 540 bis 1000 zu wechseln, muss man die Riemenscheiben vertauschen



Invertiendo la posición de las poleas, se pasa de TDF 540 a TDF 1000









Инверсия положение шкивов переходе от BOM 540 BOM 1000

Mod. NEXT AVANT

 40-60 HP







FALC

-  **ABBINABILE ANTERIORMENTE E POSTERIORMENTE AL TRATTORE**
-  **IL PEUT ÊTRE MONTÉ À L'AVANT OU A L'ARRIÈRE DU TRACTEUR**
-  **IT CAN BE FITTED BOTH IN THE FRONT AND BACK OF THE TRACTOR**
-  **FÜR FRONT- UND HECKANBAU**
-  **ACOPLABLE AL TRACTOR ANTERIORMENTE Y POSTERIORMENTE**
-  **МОЖНО ПОДСОЕДИНИТЬ СПЕРЕДИ ИЛИ СЗАДИ ТРАКТОРА**



 **OPZIONE**  **OPTION**  **OPTION**  **OPTION**  **OPCIÓN**  **ОПЦИЯ**



-  **CON ATTACCO A 3 PUNTI DOPPIO**
-  **AVEC ATTELAGE 3 POINTS DOUBLE**
-  **WITH DOUBLE 3 POINT HITCH**
-  **MIT DOPPELTER 3-PUNKT- ANHÄNGUNG**
-  **CON DOBLE ENGANCHE DE TRES PUNTOS**
-  **С ДВОЙНОЙ ТРЕХТОЧЕЧНОЙ НАВЕСКОЙ**

Mod. NEXT SP. - NEXT AVANT



40-60 HP

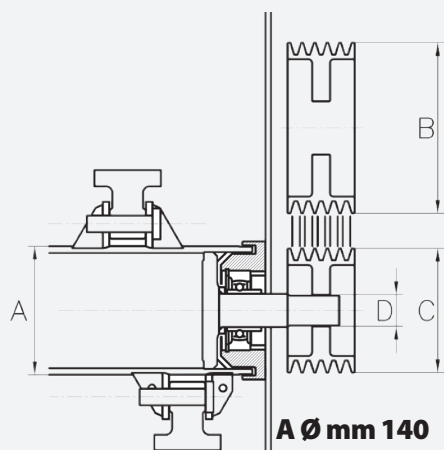

A Ø mm 140
B Ø mm 250
C Ø mm 180
D Ø mm 40

A Ø inches 5,51
B Ø inches 9,84
C Ø inches 7,09
D Ø inches 1,57

NEXT SP / AVANT	mm	inches								
1350	<table border="1"><tr><td>780</td><td>602</td></tr><tr><td>380</td><td>1002</td></tr></table>	780	602	380	1002	<table border="1"><tr><td>30,71</td><td>23,70</td></tr><tr><td>14,96</td><td>39,45</td></tr></table>	30,71	23,70	14,96	39,45
780	602									
380	1002									
30,71	23,70									
14,96	39,45									
1500	<table border="1"><tr><td>780</td><td>744</td></tr><tr><td>380</td><td>1144</td></tr></table>	780	744	380	1144	<table border="1"><tr><td>30,71</td><td>29,29</td></tr><tr><td>14,96</td><td>45,04</td></tr></table>	30,71	29,29	14,96	45,04
780	744									
380	1144									
30,71	29,29									
14,96	45,04									
1800	<table border="1"><tr><td>780</td><td>1028</td></tr><tr><td>380</td><td>1428</td></tr></table>	780	1028	380	1428	<table border="1"><tr><td>30,71</td><td>40,47</td></tr><tr><td>14,96</td><td>56,22</td></tr></table>	30,71	40,47	14,96	56,22
780	1028									
380	1428									
30,71	40,47									
14,96	56,22									
2100	<table border="1"><tr><td>780</td><td>1312</td></tr><tr><td>380</td><td>1712</td></tr></table>	780	1312	380	1712	<table border="1"><tr><td>30,71</td><td>51,65</td></tr><tr><td>14,96</td><td>67,40</td></tr></table>	30,71	51,65	14,96	67,40
780	1312									
380	1712									
30,71	51,65									
14,96	67,40									

OPZIONI OPTIONS OPTIONS OPTIONEN OPCIONES ОПЦИЯ

COPPIA RUOTE ANTERIORI IN FERRO Ø 190

COUPLE DE ROUES ANTÉRIEURES EN FER Ø 190

PAIR OF FRONT IRON SUPPORTING WHEELS Ø 190

PAAR VORDERRÄDER AUS EISEN Ø 190

PAR DE RUEDAS ANTERIORES DE HIERRO Ø 190

ПАРА ПЕРЕДНИХ МЕТАЛИЧЕСКИХ КОЛЕС Ø 190



COPPIA SLITTE FISSE

COUPLE PATINS FIXES

PAIR OF FIXED SKIDS

PAAR FESTE KUFEN

PAR PATINES FIJOS

ПАРА ФИКСИРОВАННЫХ ЛЫЖ



Via Proventa, 41
48018 Faenza (Italia)
Tel. +39 0546 29050
Fax +39 0546 663986

www.falc.eu | info@falc.eu