

-  **TRINCIA**
-  **BROYEUR**
-  **SHREDDER**
-  **HÄCKSLER**
-  **DESBROZADORA**
-  **ИЗМЕЛЬЧИТЕЛЬ**

**FALC**<sup>®</sup>

**AGILA**

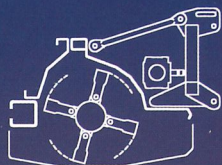

**UNIKA**

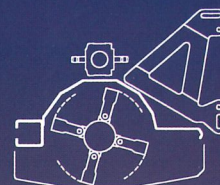

**UNIKA SP.**



**AGILA**



**UNIKA SP.**

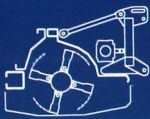

SOLO POSTERIORE



SEULEMENT ARRIERE



ONLY REAR





NUR HINTER



SOLAMENTE POSTERIOR

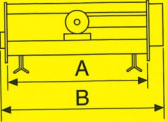

ТОЛЬКО ЗАДНИЙ

AGILA								
		HP	A mm.	B mm.	A inches	B inches	KG	
1600	50 - 100	1581	1822	62,24	71,73	660	1455	32
1800	50 - 100	1761	2002	69,33	78,82	706	1556	36
2100	50 - 100	2121	2362	83,50	92,99	750	1653	44
2300	50 - 120	2305	2546	90,75	100,24	910	2006	48
2500	50 - 120	2485	2726	97,83	107,32	965	2127	52
2700	50 - 120	2665	2906	104,92	114,41	1020	2249	56

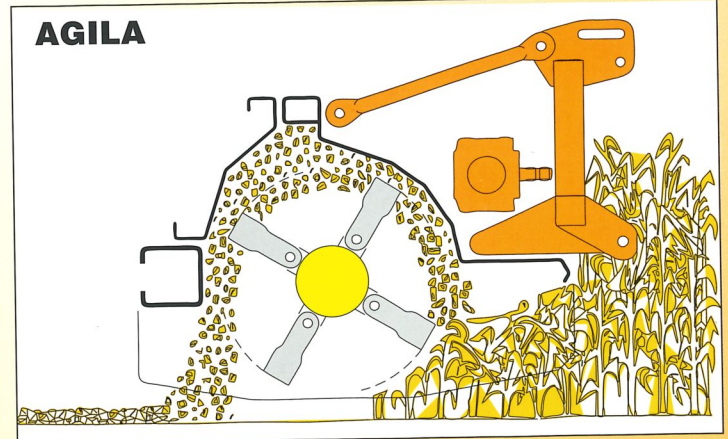

A richiesta: Attacco con spostamento idraulico



Sur demande: Attelage avec déplacement hydraulique



On request: Linking with hydraulic shifting



Auf Wunsch: Anschluß mit hydraulik Verschub



A pedido: Enganche con desplazamiento hidráulico



по запросу: гидравлическим смещением





ANTERIORE O POSTERIORE



VORDER ODER HINTER



ANTERIEUR OU ARRIERE



ANTERIOR O POSTERIOR



FRONT OR REAR



ПЕРЕДНИЙ ИЛИ ЗАДНИЙ

UNIKA								
		HP	A mm.	B mm.	A inches	B inches	KG	
1800 *	50 - 100	1761	2002	69,33	78,82	688	1517	36
2100	50 - 100	2121	2362	83,50	92,99	751	1656	44
2300	50 - 120	2305	2546	90,75	100,24	887	1955	48
2500 *	50 - 120	2485	2726	97,83	107,32	926	2041	52
2700	50 - 120	2665	2906	104,92	114,41	968	2134	56

\*A RICHIESTA - \* SUR DEMANDE - \* ON REQUEST - \* AUF WUNSCH - \* A PEDIDO - \* ПО ЗАПРОСУ

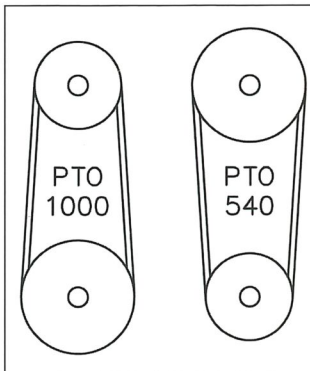

- Invertendo la posizione delle pulegge si passa da PTO 1000 a PTO 540
- Inversant la position des poulies on passe de PDF 1000 à PDF 540
- Inverting the position of the pulleys you change from PTO 1000 to PTO 540
- Um die Umdrehung von 1000 bis 540 zu wechseln, muss man die Riemenscheiben vertauschen
- Invertiendo la posición de las poleas, se pasa de TDF 1000 a TDF 540
- Инверсия положение шкивов переходе от BOM 1000 BOM 540

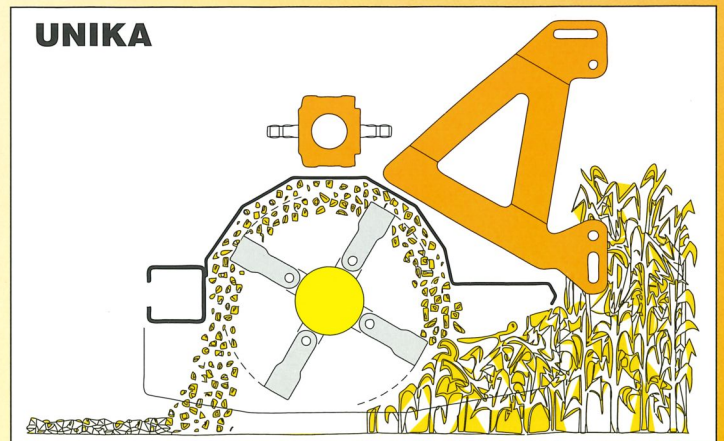

# UNIKA SPOSTABILE

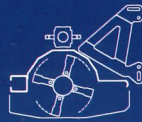

1000 (540)



ANTERIORE O POSTERIORE

ANTERIEUR OU ARRIERE

FRONT OR REAR



VORDER ODER HINTER

ANTERIOR O POSTERIOR

ПЕРЕДНИЙ ИЛИ ЗАДНИЙ

UNIKA SP. SPOSTABILE						 Con rullo Avec rouleau With roller		Mit Walze Con rodillo С катком	
		HP	A mm.	B mm.	A inches	B inches	KG		
2300	70 - 120	2305	2546	90,75	100,24	840	1851	48	
2500	70 - 120	2485	2726	97,83	107,32	880	1940	52	
2700	70 - 120	2665	2906	104,92	114,41	920	2028	56	
3000	70 - 120	3025	3296	119,09	129,76	980	2160	64	



7



8

PTO 1000

PTO 540

- Invertendo la posizione delle pulegge si passa da PTO 1000 a PTO 540
- Inversant la position des poulies on passe de PDF 1000 à PDF 540
- Inverting the position of the pulleys you change from PTO 1000 to PTO 540
- Um die Umdrehung von 1000 bis 540 zu wechseln, muss man die Riemenscheiben vertauschen
- Invertiendo la posición de las poleas, se pasa de TDF 1000 a TDF 540
- Инверсия положение шкивов переходе от BOM 1000 BOM 540



9



10

# AGILA

**AGILA 1**

- Macchina con barra posteriore e slitte regolabili
- Machine avec barre postérieure et patins réglables
- Machine with rear bar and adjustable skids
- Maschine mit hinterer Planierschiene und verstellbaren Kufen
- Máquina con barra trasera y patines regulables
- Машина с задней панелью и



**AGILA 2**

- Macchina con barra posteriore e rullo
- Machine avec barre postérieure et rouleau
- Machine with rear bar and roller
- Maschine mit hinterer Planierschiene und Walze
- Máquina con barra trasera y rodillo
- Машина с задней панелью и валиком

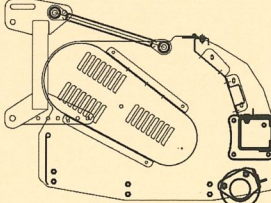

**AGILA 3**

- Macchina con barra posteriore e coppia ruote sterzanti
- Machine avec barre postérieure et couple de roues braquantes
- Machine with rear bar and pair of steering wheels
- Maschine mit hinterer Planierschiene und Steuerräderpaar
- Máquina con barra trasera y 2 ruedas girantes
- Машина с задней панелью и парой рулевых колес

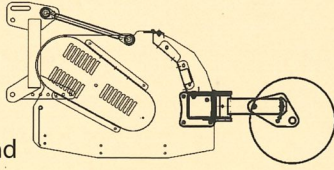

**AGILA 4**

- Macchina con rullo e lamiera di protezione
- Machine avec rouleau et tôles de protection
- Machine with roller and guarding sheets
- Maschine mit Walze und Schutzbleche
- Máquina con rodillo y chapas de protección
- Машина с валиком и защитным металлическим листом

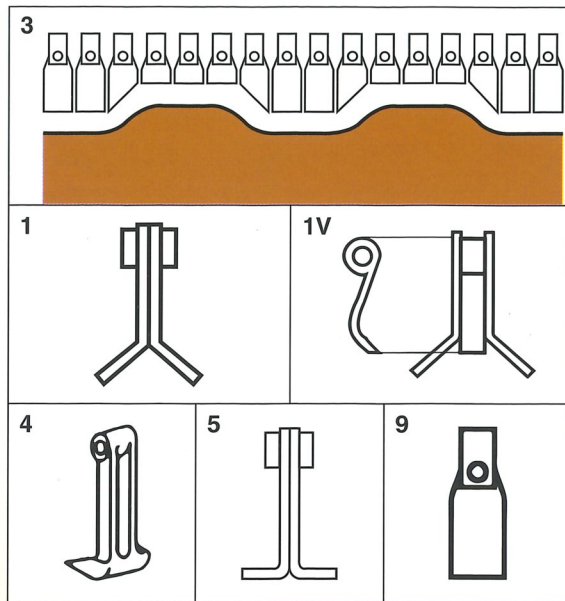
- Velocità periferica dei coltelli
- Vitesse périphérique des couteaux
- Tip speed of blades
- Messersumfangsgeschwindigkeit
- Velocidad periferica de las cuchillas
- СКОРОСТЬ ВРАЩЕНИЯ НОЖЕЙ

AGILA	m/sec.	inches/sec.
1600-1800-2100	64	2520
2300-2500	68	2677
2700	61	2402

**AGILA**

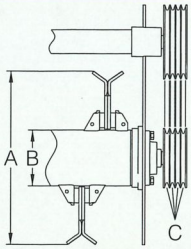

1600-1800-2100 2300-2500-2700	A	Ø mm 575 Ø mm 611
1600-1800-2100 2300-2500-2700	B	Ø mm 159x10 Ø mm 193,7x10
1600-1800 2100-2300-2500-2700	C	n. 3 n. 4

**AGILA**

G/M del rotore	Rotor U/M	Rotor's RPM	1600-1800 2100-2300-2500	N° 2132
T/M du rotor	R/M de rotor	Об/Мин ротора	2700	N° 1910

# UNIKA - UNIKA SPOSTABILE

**UNIKA - UNIKA SP. 1**

  Macchina con slitte regolabili  
  Machine avec patins réglables  
 Machine with adjustable skids  
 Maschine mit verstellbaren Kufen  
 Máquina con patines regulables  
 Машина с регулируемыми лыжами









**UNIKA - UNIKA SP. 2**

  Macchina con rullo  
 Machine avec rouleau  
 Machine with roller  
 Maschine mit Walze  
 Máquina con rodillo  
 Машина с валиком



**UNIKA - UNIKA SP. 3**

  Macchina con coppia ruote sterzanti  
 Machine avec couple de roues braquantes  
 Machine with pair of steering wheels  
 Maschine mit Steuerräderpaar  
 Máquina con 2 ruedas girantes  
 Машина с парой рулевых колес

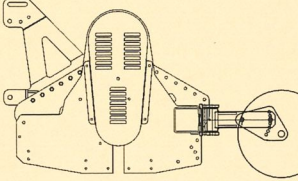



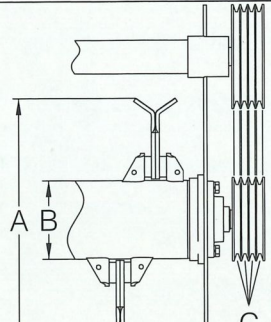



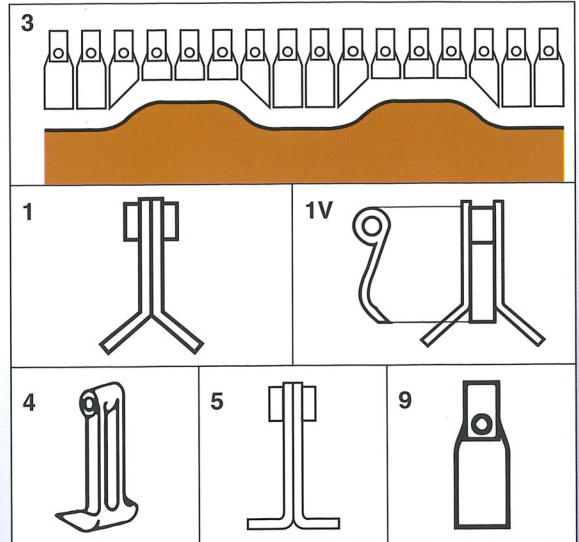

**UNIKA UNIKA SP.**









1800-2100 2300-2500-2700-3000	<b>A</b>	Ø mm 575 Ø mm 611
1800-2100 2300-2500-2700-3000	<b>B</b>	Ø mm 159x10 Ø mm 193,7x10
1800-2100 2300-2500-2700-3000	<b>C</b>	n. 4 n. 5



**UNIKA - UNIKA SP.**

  G/M del rotore	 Rotor U/M
  T/M du rotor	 R/M de rotor
 Rotor's RPM	 Об/Мин ротора
PTO 540	PTO 1000
1800-2100 2300-2500-2700-3000	1800-2100 2300-2500-2700-3000
N° 1875	N° 1800

 Velocità periferica dei coltelli  
 Vitesse périphérique des couteaux  
 Tip speed of blades  
 Messersumfangsgeschwindigkeit  
 Velocidad periferica de las cuchillas  
 СКОРОСТЬ ВРАЩЕНИЯ НОЖЕЙ

<b>UNIKA - UNIKA SP.</b>		<b>m/sec.</b>	<b>inches/sec.</b>
PTO 540	1800-2100	56	2205
	2300-2500-2700	60	2362
PTO 1000	1800-2100	54	2126
	2300-2500-2700	58	2283

FALC - Via Proventa, 41 - 48018 FAENZA (ITALIA) - e-mail: info@falc.eu - www.falc.eu

Tel. +39 0546 29050  
Fax +39 0546 663986

